

TENSTAND - WORK PACKAGE 1 - FINAL REPORT

CONTRACT N° : G6RD-CT-2000-00412

PROJECT N° : GRD1-2000-25021

ACRONYM : TENSTAND

TITLE : Tensile Testing of Metallic Materials: A Review

PROJECT CO-ORDINATOR : NPL Management Ltd

PARTNERS : National Physical Laboratory, Teddington, UK
INSTRON, High Wycombe, UK
BAM, Berlin, Germany
ZWICK, Ulm, Germany
Denison Mayes Group, Leeds, UK
Thyssen Krupp Stahl, Duisburg, Germany
ARCELOR, Florange, France
ISQ-Instituto de Soldadura e Qualidade, Oeires, Portugal
University of Strathclyde, Glasgow, UK
Trinity College, Dublin, Ireland
AGH, Kraków, Poland

AUTHORS : Malcolm S Loveday, Tom Gray and Johannes Aegerter

REPORTING PERIOD: From 1st February 2001 TO 30th April 2004

PROJECT START DATE : 1st February 2001 **DURATION :** 39 months

Date of issue of this report : April 2004



Project funded by the European
Community under the 'Competitive and
Sustainable Growth' Programme (1998-
2002)

Tensile Testing of Metallic Materials: A Review.

By

Malcolm S Loveday,¹ Tom Gray² and Johannes Aegerter³
(April 2004)

1. Beta Technology Consultant, c/o National Physical Laboratory,
Teddington, Middlesex, TW11 0LW, UK
2. Dept. Mechanical Engineering, University of Strathclyde, Glasgow,
Scotland, G1 1XJ
3. Hydro Aluminium RDB, Georg-von-Boeselager Str 21,
53117 Bonn Postfach 24 68, 53014 Bonn, Germany

[See Foreword]

Abstract

The strength of a material under tension has long been regarded as one of the most important characteristics required for design, production quality control and life prediction of industrial plant. Standards for tensile testing are amongst those first published and the development of such Standards continues today. The EU funded project TENSTAND (2000-2004) addressed a) the issues of computer controlled tensile testing, b) validation of tensile software, c) the issues of speed of testing and d) the measurement of Modulus with a view to providing a sound technical basis for further development of the Standard. This review summarises a selection of published literature relating to tensile testing, starting with a review of historical publications through to the latest literature published on the subject.

Note : This Review does not include the final results of the TENSTAND Project which will be published elsewhere.

Further information about the project may be found on the following website:
<https://www.npl.co.uk/products-services/advanced-materials/Tensile-testing>

FOREWORD

This Review has been compiled primarily by Malcolm Loveday Tom Gray and Johannes Aegerter as part of Work Package 1 of the EU Funded Project 'TENSTAND' , Contract Number G6RD-2000-00412.

The following persons also made significant contributions, either by supplying papers, diagrams and text, or by participation in the Work Package 1 meetings which were held in a) SOLLAC, Florange, France (Feb 2002) b) ISQ, Lisbon, Portugal (Sept 2002), c) TCD, Dublin, Ireland (Feb 2003) and d) USTRAT Glasgow (June 2003):

NAME	ORGANISATION	COUNTRY
J. Aegerter	Hydro Aluminium	Germany
H. Bloching	Zwick	Germany
M. Borsutzki	TKS	Germany
J-L Geoffrey	USINOR,	France
T. Gray	USTRAT	United Kingdom
S. Keller	Hydro Aluminium	Germany
H Klingelhöffer	BAM	Germany
Halina Kusiak	AGH	Poland
J. Kusiak	AGH	Poland
S. Ledworuski	BAM	Germany
R.D. Lohr	INSTRON	United Kingdom
J. Lord	NPL	United Kingdom
M. S. Loveday	Beta Technology, NPL	United Kingdom
P Matuszyk	AGH	Poland
T. McGinnley	TCD,	Ireland
M..Murphy	TCD,	Ireland
Valeriy Pidvysotskyy	AGH	Poland
M. Pietrzyk	AGH	Poland
C. Pinto	ISQ	Portugal
M. Rides	NPL	United Kingdom
H-M. Sonne	TKS	Germany
S. Sothern	CORUS	United Kingdom
Danuta Szeliga	AGH	Poland
Jenny Tagallie	USTRAT	United Kingdom
A. Wehrstedt,	DIN	Germany
D. Wieser	Hydro Aluminium	Germany

The original work package leader was Hans Martin Sonne, from TKS, who sadly retired due to ill health during the course of the project.

The list of publication given in Appendix 1 was originally compiled by H-M Sonne & M. Borsutzki from TKS, Germany, from information supplied by various partners, and has been reformatted in date order.

After starting the TENSTAND project the opportunity arose to include a partner from a 'New Accession State' (NAS), a new country in the process of joining the European Union and thus Prof M Pietrzyk and his colleagues from AGH (Akademia Gorniczo-Hutnicza), Kracow, Poland were invited to join the project. This enabled direct access to literature from some eastern bloc countries to be examined and thus a list of Polish papers relating to tensile testing, together with Abstracts and selected diagrams from key papers are included in Appendix 2a, and a similar list from the Russian literature is given in Appendix 2b.

CONTENTS

Abstract.....	2
Foreword.....	2
Contents.....	3
1. Introduction	5
2. Symbols & Nomenclature.....	6
3. Historical Background	7
3.1 General	8
3.2. Historical Background to Tensile Testing Standards.....	10
4. Standards: Recent Developments	12
5. Alignment & Gripping	14
5.1 Gripping Systems	12
5.2 Alignment.....	12
5.3 Strain rate Variations	14
6. Testpiece Geometry.....	19
7. Speed & Control of Testing.....	21
7.1 Background.....	17
7.2 Developments in testing Machine Technology	18
7.3 Effects of testing rates on properties	19
7.3.1 Results before servo control (pre 1970)	21
7.3.2 Results from servo controlled machines	22
8. Uncertainty of Measurement.....	29
9. Round Robin Experiments	30
10. Measuring Systems & Data Recording	35
11. Other Issues	
11.1 Software validation.....	29
11.2 Modulus Measurement.....	30
11.3 r & n measurements.....	31
12. Discussion	34
13. Conclusions	45
14. Acknowledgements.....	38
15. References.....	38
15.1 STANDARDS.....	38
15.2 PAPERS & BOOKS	40
Table 1	46
Figures	47 - 89
Appendices:	
<u>APPENDIX 1.</u> List of Papers relating to Tensile Testing compiled during TENSTAND Project	90 -99
<u>APPENDIX 2a.</u> List of Papers relating to Tensile Testing compiled during NAS- TENSTAND Project a) Polish Papers.....	100 - 124
<u>APPENDIX 2b.</u> List of Papers relating to Tensile Testing compiled during NAS- TENSTAND Project b) Russian Papers	125 - 145
<u>APPENDIX 3:</u> Precision of Tensile Testing and	146
Estimation of Uncertainty of Measurement.	

1. Introduction

The strength of a material under tension has long been regarded as one of the most important characteristics required for design, production quality control and life prediction of industrial plant. Standards for tensile testing were among the earliest standards to be published and the development of such Standards continues today.

The revised European Standard, EN 10002 Pt1, published in 2001, covering Tensile Testing, now recognises the dominance of computer controlled testing machines, but the systematic technological evidence on which such a Standard should be based is not currently available. The EU funded project 'TENSTAND' (2000-2004) seeks to address this deficiency by addressing:

- a) issues of computer controlled tensile testing,
- b) validation of tensile test software,
- c) issues of speed of testing,
- d) measurement of Modulus,

all with a view to providing a sound technical basis for further development of the Standard. The project was given the acronym '**TENSTAND**' from the words **Tensile Standard**. Further information about the project may be found on the following website:

<https://www.npl.co.uk/products-services/advanced-materials/Tensile-testing>

As part of the project it was agreed to review relevant published literature relating to tensile testing machine control characteristics, modulus determination and inter-comparison exercises aimed at compiling data suitable for the assessment of measurement uncertainty

The uni-axial tensile test is the primary method used for quality control and certification of virtually all metallic materials produced by casting, rolling and forging processes, representing well in excess of 80 million tons per annum of various ferrous and non ferrous alloys primary feed stock sold throughout the European Community and having an approximate value of 50,000 million euro. Rapid turn-round of testing is essential to prevent production line delays and automatic testing is now becoming commonplace with robots feeding computer controlled testing machines. The feed-stock metallic materials are subsequently used by the entire engineering manufacturing sector to produce products as diverse as automobiles, white-ware domestic products such as cookers, washing machines and refrigerators, power plant, aerospace products as well as the civil engineering construction industry. Thus the tensile test may be regarded as one of the fundamental foundation stones on which the whole of the manufacturing sector is based and represents a massive proportion of the European and World Wide economy.

It is critically important that reliable and reproducible tensile data is produced at different laboratories and test houses throughout the World, if fair trade on a 'level playing field' basis is to be maintained. Otherwise, inadequacies in the Standard could be exploited to give unfair commercial advantage to companies interpreting the Standard in a manner that was not intended by the standards writing body.

Reliable tensile data, which is now generated largely by computer controlled testing machines, is also crucial in the design of safety critical components in power plant, nuclear and aerospace applications. Unreliable data in these regimes can result in catastrophic failure leading to human fatalities, or at a minimum, significant replacement costs of technologically advanced engineering plant. Tensile properties are also crucial in the bio-medical field for the reliable design of surgical implants where premature failure can result in considerable human suffering.

This review summarises a selection of published literature relating to tensile testing, starting with a review of historical publications through to the latest literature published on the subject.

Note: Where appropriate, papers have been cited in the body of the text of this document, as indicated by Author, followed by the year of publication and are listed in Section 13, References. However for the sake of completeness the full bibliographic list of papers compiled within the TENSTAND project and the NAS-TENSTAND project (Polish & Russian papers) are given in Appendices 1, 2a & 2b respectively.

2. Symbols and Nomenclature

Symbol	Unit	Description
A	%	Percentage elongation after fracture taken from stress-strain diagram. Values only valid if fracture/necking between edges of extensometer.
A_g	%	the percentage non-proportional elongation at maximum force A_g out of a smoothed stress/strain
a	mm	Measurement of the thickness: Accuracy better as 0.5%, Note: when $a < 2$ mm than the resolution must be smaller than 0,01 mm
b	mm	Measurement of the width: Accuracy better as 0.5%
d	mm	Diameter of parallel length of circular testpiece
F_v	N	Preload or –stress resp.: $< 5\% R_{p0.2}$
---		Data sampling frequency/storage criterion
f_{min}		Elastic range: $f_{min} = 10 \text{ MPa/s } (R_{p0.2} \times q) * 100$ (acc. [2] Annex A) $q =$ Class of the machine in accordance with ISO 7500 -1
$\Delta\varepsilon$		Plastic range: $\Delta\varepsilon \leq 0,05\%$ (e. g. $L_0 = 80 \text{ mm} \rightarrow \Delta L \leq 0,04 \text{ mm}$)
L_c	mm	Parallel length
L_e	mm	Extensometer gauge length
L_o	mm	Original gauge length
$m,$ $R_{p0.2}$		Method I (for exact values): determination of the elastic line per linear regression, recommended limits: between 10 and 50 % of $R_{p0.2}$. Verification of the fit of the elastic line with the measured curve, if necessary recalculated with other limits. Method II (not so precise): use a fixed slope of 70 GPa for aluminium alloys
n		Strain hardening coefficient (see 11.3.2 in the text)
r		Plastic strain ratio (see 11.3.3 in the text)
R_{eh}	MPa	Upper Yield Strength
R_{el}	MPa	Lower Yield Strength
R_m	MPa	Tensile strength, i.e, the maximum of the stress/strain curve
R_p	MPa	Proof Strength,
S_0	mm ²	Original Cross-sectional area of testpiece in parallel length
v		Testing rate
v_1		Constant crosshead velocity, which gives an effective stress rate at the specimen in the elastic range $v_1: 10 \text{ MPa/s} \pm 20\%$, maintain this speed up to 0.5 % plastic strain, pre-tests to evaluate the correct speed in the elastic range are necessary
v_2		Constant crosshead velocity, which gives an effective strain rate of $0,00667/\text{s} \pm 20 \%$, based on the parallel length (under ignoring the compliance of the testing equipment) v_2 must be reached by 2% plastic strain (no acceleration effects in the range for the evaluation of n - and r -value). To avoid jumps (acceleration effects) in the stress/strain curve the velocity change from v_1 to v_2 must be done smoothly.

Note : See ISO 6892 or EN 10002 –1 for additional information and definitions.

3. Historical Background

3.1 General

The knowledge of a materials ability to safely sustain a load before breaking has been of paramount importance to man ever since structures were first built. It is difficult to conceive that the qualitative ranking of softwoods, hardwoods and stone were unknown in the Neolithic time, and the Greek, Egyptian, Roman and Norman civilizations clearly had an understanding of material strength perhaps purely based on experience. However it is not until the Renaissance period in the 16th century that documentary evidence from the writings of Leonardo da Vinci are found, which show that quantitative methods were employed to measure the differences in the material properties, Timoshenko (1953) and Gray (1988).

However, in the general context of material science, it is interesting to note that the earliest recorded evidence of a written standard, or specification, dates back to the 4th Century BC. The 'Stele of Eleusis', Figure 1, is a stone tablet inscribed with the specification of the composition of bronze spigots used for keying together the stone blocks used for constructing columns in Greek buildings, Varoufakis (1940). The Stele, which is ~ 40cm across, was found in 1893, and cites a decree relating to the composition of the 11:1 ratio of copper to tin for the bronze spigots (*poloi*) used in the construction of a new stoa (portico), designed by the architect Philo and subsequently which became known as the Philonion Stoa in Eluesis. (ISO Bulletin, (1987)). This stele is important since it clearly implies that a) the Greeks at that time understood the importance of the relationship between the composition of the alloy and its mechanical properties and b) it is the first reference to the use of turning of a metallic component on a lathe to achieve the desired dimensions. The spigots inserted into holes in square bronze blocks (*empolia*) which were set into the stone drums of the columns, Figure 3. Since each of the fourteen column of the stoa comprised of ten drums, a total of 308 *empolia* were required together with 154 *poloi* , which together represented over 3000 Kg (~3 tons) of bronze, (Varoufakis, 1987).

Galileo Galilei [1564-1642] presented the first serious mathematical treatment of the elastic strength of a material in a structure subject to bending in (1638). It is illustrated in the well known drawing that appeared in his '*Discorsi e Dimostrazioni matematiche*' published in Leiden, Figure 2, as discussed by Todhunter & Pearson, (1886).

The concept that a simple relationship exists between the applied load and elastic (recoverable) deformation of a material was published in 1676 by Robert Hooke [1635-1702] in the form of an anagram 'The true theory of *elasticity* or *springiness*: c e iiii n o sss tt uu.' The explanation of this cryptogram was not given until two years later in the phrase: '*Ut tensio sic vis*' – the power of any spring is in the same proportion with the tension thereof.' (Unwin (1910))

Thomas Young [1773-1829] is now associated with the measurement of the modulus of elasticity of materials although most modern day research workers would not recognise the description that he used to express the relationship between stress and strain:

'A modulus of the elasticity of any substance is a column of the same substance capable of producing a pressure on its base which is the weight causing a certain degree of compression as the length of the substance is to the diminution of its length.'

One of the earliest machines used for the systematic measurement of tensile strength was developed by a Dutch physicist Petrus van Musschenbroek (1692-1791) Figure 3. The basic concept of a 'steel-yard' used to apply a load to the sample has subsequently been used in many designs of tensile testing machine.

George Rennie jun. (1818) also made a significant contribution to the understanding of the strength of materials and some of his correspondence with Thomas Young was published in the Phil. Trans of the Royal Society. This included details of a lever testing machine which was used to test a variety of materials, including cast & wrought alloys, wood, and stone (marble, limestone, granite etc) in compression and under tension Figure 4.

William Fairbairn made a significant contribution to the systematic assessment of the strength of materials at high temperatures using the machine shown in Figure 5 and Figure 6. (Fairbairn, (1842) & (1856)). The sample could be heated up to 'red heat' in a liquid bath heated by a fire grate, which would be removed when the desired temperature had been achieved. Loads up to 446 kN could be applied to the testpieces by the lever system (Smith, (1963) & Loveday,(1982)).

David Kirkaldy (1820-1897) also made an important contribution to the determination of the strength of materials by designing and building a large horizontal servo-hydraulic testing machine in order to undertake testing to uniform standards, (Smith (1982)). The machine was completed and his test house in Southwark, London, opened for business on 1st January 1866. Kirkaldy subscribed to the view that in matters relating to the strength of materials, '*Facts not opinions*' are important, Figure 7 and indeed this motto can still be seen today inscribed over the doorway of his test house. This is now a Museum housing his testing machine, which is still in working order, Figure 8 & Figure 9. The Museum is open to the public by arrangement with the Trustees of the Charitable Trust, which is now responsible for maintaining the machine, (Skilton,(1990)).

At about the same time the importance of materials testing was nationally recognised in Germany by the establishment of in 1871 of Bundesanstalt für Materialforschung und prüfung (BAM) in Berlin. The pioneering contribution by Adolf Martens (1850-1914) on mechanical testing undertaken at BAM, was reviewed by W. Ruske in the volume published in 1971 commemorating the

centenary of the formation of BAM, and has recently been updated in the 125 year commemorative volume edited by Ruske, Becker & Czichos (2003). This volume contains a wealth of information relating to the history of testing of materials as does the '*Handbuch der Werkstoffprüfung*' (Siebel,(1958)).

Prof Johann Bauschinger [1834 – 1893] is credited with the introduction of the double-sided extensometers, Figure 10, which allow compensation for curvature or misalignment of the testpiece. This made a significant improvement to the measurement of tensile strain, and allowed sufficient precision of measurement to observe that yield stress is lowered when deformation in one direction is followed by deformation in the opposite direction. This is now known as the '*Bauschinger effect*' (Bauschinger,(1881)).

One of Martens notable contributions was the further development of double sided extensometers used for measuring the elongation of tensile test pieces, which either comprised of a lever and scale type, or the mirror and rhomb type Figure 11 (Morley (1940) , Figure 11b, (Unwin,(1910)).

In the last decades of the 19th century an important series of inter-comparison exercises on tensile testing was undertaken in the UK and published as Reports of the British Association (Kennedy et al (1895), (1896) & (1897)) subsequently summarised by Unwin (1910). It is interesting to note that by using long gauge length test pieces with optical extensometry, the reproducibility of the Modulus of Elasticity results was frequently better than that observed today, as may be seen in Figure 12. The mean value of the data of 13,228 tons/in² corresponds to 203.2 GPa with an uncertainty of 1.7% at the 95% confidence level.

3.2. Historical Background to Tensile Testing Standards

The importance of tensile testing of metallic materials should be recognised by the fact that one of the earliest British Standards, BS18 covering this subject, was published in 1904. The first British Standard, published in 1903, set down the required shapes (sections) of rolled metallic products; this was issued by the British Engineering Standards Association (BESA), which included leading engineers and scientists, and which was first constituted on 26th April 1901. This organisation was supported by The Institution of Civil Engineers, The Institution of Mechanical Engineers, the Institution of Naval Architects, The Iron and Steel Institute and the Institution of Electrical Engineers. By 1920 there were over 300 committees in the UK focussed on the specification, production and testing of engineering products. In April 1929, the Association was granted a Royal Charter. Shortly afterwards, the Association of British Chemical Manufacturers requested that chemical standards should be incorporated under the charter and as a consequence a supplemental charter was issued in 1930, which included a change of name of the BESA to the British Standards Institution (BSI), (Woodward, 1972). By 1939, there were over 850 published British Standards

for a wide range of engineering, chemical and building materials, underpinning industrial contracts worth millions of pounds. The rationalisation of industrial components was a notable achievement of the introduction of standards, a significant example being the reduction of the number of different types of tramway rail sections from 75 to a mere 5 types.

One of the first standards relating to tensile testing was Report No 3 issued in 1903 entitled '*Report on the Influence of Gauge Length and Section of Test Bar on the Percentage Elongation*' which was published by BESA and remained as BS3 for many years. Another standard relating to tensile testing, BS18, was published in 1904, but rather surprisingly, it specified only the nominal geometry of test bars suitable for the use in the determination of tensile properties of metallic materials, Figure 13 and Figure 14. The range of test pieces was extended in 1907 and again in 1910, but it appears that it was not until 1938, that BS18 incorporated details specifying the test method and then started to look like the standard that has become familiar to many thousands of engineers. BS18 was first published in about 1910 and survived several revisions until being superseded by the European Tensile Testing Standard in 1990.

In Germany, the "German Society for Materials Testing " was responsible for testing specifications, until the foundation of DIN in 1917. In 1900 "Publication N°1 Grundsätze für einheitliche Materialprüfungen" (Fundamental requirements for unified materials tests) was published by A. Martens, which covered tensile, impact and bend testing. For the tensile test this was transferred to DIN 1604:1924-06 (later on DIN 50145:1952-06 until publication of DIN EN 10002-1:1991-04). DIN Standard 50125:1940-08 for test pieces was published later and has been revised so that it remains valid until the present alongside DIN EN 10002-1.

The first American tensile testing standard was issued in 1924 (ASTM E8-24T), and ASTM subsequently issued it as a high temperature tensile testing standard in 1931, whereas the first equivalent high temperature British Standard was not produced until 1963. Tensile testing standards across Europe were harmonised with the publication of EN 10002 Part 1, which superseded the individual national standards, whereas ASTM continues to issue and revise ASTM-E8. The equivalent International Standard covering room temperature tensile testing is ISO 6892. The standards associated with mechanical testing of metals have been reviewed by Roche & Loveday (1992) and more recently by McCarthy (2003)

At the turn of the 20th century, tensile testing practice had been underpinned by a series of inter-comparison exercises undertaken by the leading practitioners in the field. These results were summarised and published by Unwin (1910) and in a series of reports published by the British Association relating to Calibration of Instruments Used in Engineering Laboratories (Kennedy et al, (1895), (1896) & (1897)).

4. Standards: Recent Developments

Most tensile testing Standards specify the rate at which the testing should be carried out, since it is known that some materials yield at different strength levels depending upon whether the test is carried out slowly or rapidly. It was always the an aspiration that materials tested in compliance with the Standards should give similar strength levels regardless of the laboratory at which they were tested. It was also assumed that the Tensile Strength, R_m , formerly known as the Ultimate Tensile Strength (UTS) was less sensitive to testing speed, and hence the testing rate was permitted to be increased after the determination of Proof Strength, R_p , or Upper and Lower Yield Strengths, R_{eh} , & R_{el} , had been determined. This enabled the test to be completed in a shorter time. Reduction in the total time to complete a test was, and still is, an important consideration especially for test houses involved with product release testing for large commercial organisations involved with the production of steel and other industrially important alloys. Schematic diagrams illustrating the form of tensile stress-strain (or load-displacement) curves showing a) upper and lower yield characteristics, and b) proof stress characteristics are shown in Figure 15 & Figure 16 respectively.

On machines developed in the mid 20th century the testing machine was frequently controlled manually through yielding events to maintain a constant testing speed, and some of the testing speed control procedures embodied in the Standards reflect this practice. However the majority of modern-day testing machines are now computer controlled and are capable of maintaining control throughout yielding, provided the machine is operated in closed-loop strain control using an extensometer attached to the testpiece gauge length. Rather surprisingly it became clear in the mid 1990's that ambiguity existed in the interpretation of the specified testing conditions in the Standards and widely different practices still seemed to exist across the world. The European project 'TENSTAND' was thus conceived to address the issues raised by computer controlled testing machines and to evaluate the differences in measured material properties as a consequence of alternative interpretations of the Standard.

The EN & ISO standards for room temperature tensile testing are currently being reviewed, which is normally required at a minimum of 5-yearly intervals, and it is expected that the dual voting procedures will be applied under the 'Vienna Agreement' so that the ISO & EN Standards will be identical. Working Groups have been established to consider proposed changes to the sections covering the speed of testing and an Annex addressing Uncertainty of Measurement. The EN working group has proposed that the testing speed range should be maintained within a tolerance of $\pm 20\%$ of the designated strain rate, throughout the elastic region and until the upper yield stress, R_{eH} , or proof stress, R_p , has

been determined. Three permitted testing speeds are being considered to recognise world-wide custom and practice, namely:

- a) $0.00025 \text{ s}^{-1} \pm 20\%$,
- b) $0.001 \text{ s}^{-1} \pm 20\%$
- c) $0.00007 \text{ s}^{-1} \pm 20\%$

all as indicated in Figure 16. [*Note : These speeds may subject to revision at the ISO Meeting to be held in China in October 2004 following the recommendations of an ISO Working Group, ISO TC 164 SC1 WG4]*

The first speed **(a)** will be the speed generally used, but speed **(b)** has been included since it is thought to align with the rate widely used by steel plate manufacturers and aligns with an ASTM product standard E370. Speed **(c)** aligns with the speed generally used for high temperature testing and for aerospace products.

To allow the test to be completed in a reasonable time, the testing speed may be increased for the determination of the lower yield stress, R_{eL} , and the percentage yield point extension, A_e . The speed may be increased further for the determination of tensile strength, R_m . The faster speeds are permitted for the determination of R_{eL} and R_m because experience generally indicated that these parameters are less strain-rate sensitive than R_{eH} or R_p , although recent findings from the TENSTAND project indicate that this assumption is not true for all materials.

Thus three speeds may be applied for different regimes in order to shorten overall testing times.

A comparison of the new proposed testing speeds with those currently specified in EN10002 Part 1:2001 is shown in Figure 17.

5. Alignment & Gripping

5.1 Gripping Systems

Current Standards are silent, on the whole, on the question of different gripping systems in relation to different test products and/or specimen configurations. This is understandable, as there are many different types of system in the market and many potential variations within these types. It would therefore be difficult to set down a coherent set of requirements to cover the potential variations. Nevertheless, gripping systems and their uses, or abuses, may be responsible for substantial differences in the mechanics of testing and their outcomes. It is highly advisable that the user is at least aware of these potential sources of variation and knows how to minimise them in a test procedure.

Gripping systems can interact with the mechanics of testing in two major ways. Firstly, the system may not apply uniform strain across the sample cross-section or along its length. This may occur due to misalignment, or deficiencies in clamping or the precision of grip components. The effects may include

- Side-to-side or lengthwise variation in the clamping or pinning arrangement.
- The gripping system introduces a non-linear element in the load train and this may be responsible for unexpected departures from the specified strain rates during the test.

These points will now be discussed in greater detail.

5.2 Alignment

If the alignment of the pulling heads of the machine does not coincide with the symmetry axis of the test specimen, the desired uniform stress application will be corrupted by an imposed bending stress (Bressers (1995) Figure 18. This will have several effects - false indication of Modulus, suppression of upper yield phenomena and decrease in the indications of limit of proportionality, apparent lower-yield strength or proof strength. The extent to which this occurs for a given misalignment depends on the least transverse dimension of the specimen. Gray and McCombe (1992) showed that for a rectangular cross-section or strip of thickness t , a misalignment in the thickness direction of h will cause a reduction in the apparent yield load of $6h/t$ approximately and a drop of $2h/t$ in the limit load for a non-work-hardening material. The corresponding reductions for a cylindrical shape are $8h/d$ for the apparent yield and $2h/d$ for the limit load. To put this in context, if a test is carried out on 5 mm thick strip, a misalignment of 0.1 mm would cause a 12% reduction in the apparent limit of proportionality.

Even if the pulling heads are perfectly aligned in the machine, alignment of the specimen depends substantially on the type of end grip used and the degree of precision that can be applied in fitting the specimen into the load train. Gray and McCombe (1992) investigated the performance of three different conventional grip types - internally threaded grips, used for cylindrical specimens with screw

ends, collet grips, designed for button-ended specimens and self-tightening wedge grips, used with plain-ended cylindrical specimens Figure 19. Alignment checks were carried out, by applying strain gauges to 12 mm diameter test specimens Figure 20. The test results showed significant deterioration in alignment following the sequence of grip types as given above, even when the greatest possible care was taken in terms of assembly Figure 21.

In the case of the wedge grips, the misalignment was traced to minute side-to-side differences in indentation of the specimen ends by the serrated grips, leading to an overall offset of the specimen as the self-wedging action developed. Some realignment of the specimen in the grips took place as the tensile load was increased, but the level of bending stress at the point of yielding was still at over 30% of the direct stress, which is an unsatisfactory result. Similar effects were found in the case of rectangular section specimens in wedge grips.

The superior performance of the threaded grips seemed to be due to a more even transfer of load from the grips through the thread contact - by local yielding of the threads together with a tendency for the male and female threads to self-align naturally. Substantial superimposed bending action was identified in the lower range of elastic loading but this quickly reduced to under 20% in the worst-affected region of the specimen before yielding occurred. The performance of collet-type grips on button-head specimens was intermediate between the threaded and wedge-action types, but this will depend in general on the precision of component fits and assembly.

There is little evidence in the literature concerning the alignment of proprietary powered gripping systems used on plain-ended specimens. Most of the problems in the wedge grips arise during the axial movement of the grip elements as the load is taken up and therefore a, power-driven mechanism could be superior if it applies a high load through a pure transverse and equal motion of the gripping platens. Transverse compression of the specimen ends will however lead to axial expansion along the length and it is still important to ensure that axial compressive loads do not arise, which could cause the specimen to misalign.

Most testing systems employ couplings or universal joints, which should, in theory, self-align in two mutually perpendicular directions as the tensile force is applied and are often relied on to do so. This cannot be depended on, however, as noted by Bressers (1995) as the couplings will tend to lock up as the load increases, thereby allowing transverse forces to develop. McEnteggart and Lohr (1995) mention an adaptive self-aligning tensile grip based on small hydraulic pistons and low friction flexible couplings. Alignment problems are more critical for ceramic testing where premature failure occurs as a consequence of bending.

The problem of alignment has been investigated more often in relation to fatigue testing, where the results will be more apparently sensitive to non-uniform stressing. Fischer and Haibach (1987) discuss the use of a strain-gauged

dummy specimen to check and improve the alignment of flat specimen gripping devices and there are other references in the literature to similar techniques.

The alignment of load frames and associated components for fatigue testing was thoroughly investigated by a consortium of researchers in the Netherlands (Bressers (1995)). (Note that fatigue testing is often carried out through zero load and therefore universal couplings cannot be used.) Bressers (1995) also provides alternative designs for a clamping arrangement to grip a button-headed dummy specimen. Specific recommendations on alignment are given and the authors claim that the levels of accuracy proposed are compatible with the specifications offered by a number of machine manufacturers. These standards have been set in relation to the needs of fatigue testing but the benefits in obtaining the specified accuracy from the point of view of tensile testing can be determined through the approximate evaluations of misalignment noted earlier.

Guidance on the measurement of alignment has also been provided in an NPL Good Practice Guide (Kandil, 1998), which is primarily focussed on alignment of fatigue testing machine, and in ASTM E1012-99 '*Standard Practice for Verification of Specimen Alignment under Tensile Loading*'. A European Standard is currently being processed based on the recommendations of Bressers et al (1995) for testing of Ceramics, and more recently consideration is being given to the development of an ISO Standard for Alignment of Fatigue Testing Machines under the auspices of ISO TC 164 SC 5 WG11. It should be noted that it is now generally recognised that two sets of four strain gauges are sufficient to determine the magnitude and direction of maximum bending, and the proposed ISO Standard will reflect this view.

5.3 Strain Rate Variations

Different gripping systems tend to perform differently in terms of stiffness and/or slip and this can have a profound influence on the variation of strain rate, particularly if the control of testing rate is effected via control of crosshead separation rate.

Gray and McCombe (1992) used a paired test-piece approach to compare the relative performance of threaded grips and wedge grips applied to cylindrical steel specimens and using the same machine under crosshead-rate servo-control. In this form of control, the strain rate in the specimen gauge length normally accelerates substantially after the transition from elastic to plastic behaviour. The reason is that during the elastic loading phase, much of the displacement is absorbed by extension of the grips and other components in the load train, whereas, after yielding, as there is little increase in load, most of the displacement goes to strain the test specimen. In the threaded/wedge grip comparison the ratio of plastic to elastic strain rate was 10 times for the threaded grip and 25 times for the wedge system. This shows the effect of the more compliant gripping arrangement. The large and less predictable ratio of strain rates associated with wedge grips makes it much more difficult to determine appropriate initial machine settings to achieve the desired plastic strain rate in the post-yield regime.

Gray (1992) compared tests carried out using powered transverse grips Figure 22 and self-clamping wedge grips Figure 23, applied to rectangular cross-section steel plate specimens of 40 mm thickness. In this case, the crosshead displacement rate of the wedge grips required to be set at about 5 to 10 times that of the powered grips in order to achieve the same strain rate in the post-yield stage. If this difference in behaviour is not recognised, a significant difference in reported yield strength would be obtained.

Even in the case of the powered grips, the strain rate in the specimen was not uniform in all cases. Local plasticity in the grip area tends to intervene at a point just before yielding Figure 24 and in the case of wider specimens at higher nominal loads. This resulted in some slippage until the follow-up action of the powered grips re-established the crosshead displacement rate originally set. The wedge action grips, on the other hand, tend to stiffen as the load increases.

Several grip types and specimen forms were examined comparatively in an inter-laboratory investigation of procedures for testing non-ferrous materials (Gray and McCombe (1992)). The materials were 11 mm diameter leaded brass bar, 10 mm diameter Inconel 600, 2.3% Mg aluminium alloy sheet (1.5 mm thick) and 2 mm diameter high-purity copper wire. These materials were mostly work-hardening and, in all cases, showed significant or highly significant strain rate sensitivity and/or variability when tested at alternative rates a decade apart, representing the extremes of the EN 10002 procedure then in force. Grip systems included wedge grips, pin/hole clevises, powered grips and threaded grips. Seven different testing machines were applied, including open and closed loop hydraulic and servo-mechanical systems. Extensometer control and crosshead-rate controls were applied in various comparisons.

As indicated earlier in the case of testing steels, the best control of strain rate for cylindrical specimens was obtained using threaded grips and extensometer control Figure 25, In cases where crosshead-rate was implemented, it proved to be very difficult, if not impossible, to maintain the strain rate within the decade band permitted by the standard, especially where wedge grips were also employed Figure 26. Displacement rates to give the required gauge length strain rates could not be set correctly without carrying out pilot tests to establish a suitable compromise setting. Considerable difficulties were also experienced in the case of the thin sheet tests Figure 27, due to slippage. The use of the pin/clevis system was particularly helpful in reducing strain rate variation under crosshead-rate control Figure 28. A significant conclusion of this report on 'gripping and control mode' was that "Under displacement (crosshead) rate control, grip effects predominate, particularly for wedge grips."

The difficulty of achieving the desired straining rate on the testpiece when operating the testing machine in cross head control has recently been confirmed by Aegerter et al (2001). It may be seen in Figure 29 that although the cross remains at a constant rate, because of the relative change of compliance of the testpiece during yielding, the strain rate of the testpiece changes by a factor of ~ 4.8 between the elastic region prior to yielding, and the plastic region after yielding, as shown in Figure 29d.

The contrast between hydraulic-powered parallel grips and wedge grips was also investigated in an inter-laboratory study by Aegerter et al (2001) on the testing of sheet materials, ranging in thickness from 0.75 mm to 5 mm and covering yield strengths from 134-240 MN/m² (Figures 30-34). Materials included bake-hardening steels, CuZn Alloy in soft and hard conditions, CuSn Alloy, clad AlMn alloy, AlMg3.5Mn and Z ST E180BH. This range included some materials with upper and lower yield points and other work-hardening materials, characterised by proof strength determinations.

Tests were carried out using crosshead-rate control and extensometer control. In the former case, the speed was changed following the yield point determination, in order to comply with the strain rates designated in EN 10 002-1. The authors argued that the wedge grip arrangements in both laboratories would have been substantially more compliant than the powered grips, so that the acceleration of testing rate from the elastic to the plastic loading regime would have been more critical, as described above. Not all of the materials were strain-rate sensitive, but there was a strong tendency in those materials that were sensitive for the yield strengths to indicate significantly higher values when tested in the wedge grip systems. In contrast, much greater consistency was obtained between different systems when extensometer feedback was employed and the authors note that this control arrangement made for “easier execution, as it is not necessary to verify the testing speed in preliminary tests”.

Additional information has now also been published concerning tensile testing in accordance with the current issue of EN10002 Part 1 (Aegerter J., Bloching H.,2002) and concerning the issue of testpiece manufacture (Aegerter J., Bloching H.,(2003).

In the TENSTAND Project a laboratory intercomparison exercise has been undertaken using a number of alloys representing industrially important classes of materials and full details of the results are reported elsewhere (Klingelhoffer *et al* 2004), however it should be noted that a matrix of three different testing conditions were used to evaluate the difference between a) slow strain rate control followed by a faster cross head control, b) slow cross head control followed by a faster cross head control, and c) a slow strain rate control followed by a slow cross head control through to failure. The specific details of the TENSTAND test matrix conditions are as follows-

Matrix 1.1 Initially Strain-rate control at 0.00025 s⁻¹ until R_{p0.2} has been determined, then 0.008 s⁻¹ in displacement (crosshead) control.

Matrix 1.2 Initially crosshead control at an equivalent rate of 0.00025 s⁻¹ until R_{p0.2} has been determined, then 0.008 s⁻¹ in displacement (crosshead) control.

Matrix 1.3 Initially Strain-rate control at 0.00025 s⁻¹ until R_{p0.2} has been determined, then 0.00025 s⁻¹ in displacement (crosshead) control.

Because the participants were all asked to report elapsed time in addition to the conventional measured parameters of load, displacement, strain etc, it has been

possible to clearly demonstrate the differences in strain-rate between the different control modes as indicated in Figure 35. It is clearly seen in the example, as reported earlier by previous workers, that, when operating the testing machine in cross head control, the strain rate during yielding is not constant and can thus end up with higher values of proof strength as clearly shown in Figure 35. Although the strain as a function of time may start off at similar rates in strain rate control and in cross head control, as yielding starts to occur, the the slope of the strain – time curve increases when the machine is in cross head control, whereas in strain-rate control the slope of the strain-time graph remains constant.

6. Testpiece Geometry

6.1 Testpiece Geometry and Ductility Evaluation

Ductility has been defined qualitatively as the ability of a material to deform plastically before fracturing (ASTM E6-89).

The earliest measurements of ductility by Fairbairn, Mallet in 1858, Kirkaldy in 1863 and Barba in 1880 were total elongation and either reduction in area or some other measurement related to the reduction of the specimen cross-section at separation. Various ductility indices have been proposed, but total elongation at fracture remains the common method of measuring ductility. It was also recognised by the early investigators that specimens of different shape, dimensions and gauge length gave different values of elongation. Thus various formulae had to be developed to relate fracture elongation to cross-sectional area and gauge length. Table 1 gives some examples.

The dimensions of tensile test specimens are designated in many Standards as 'proportional' or 'non-proportional'. In the former, the gauge length is set in proportion to the square root of the cross-sectional area, which may be either rectangular or cylindrical viz

Gauge length $L_0 = k\sqrt{S_0}$ where k is a suitable constant (very often 5.65) and S_0 is the initial cross-sectional area. (The 5.65 constant derives from the value $5 \times \sqrt{(4/\pi)}$, which will provide the same cross sectional area as a cylindrical specimen where the gauge length is set at five times the diameter.)

The 'proportional' requirement is based on the principle that geometrically similar specimens should deform similarly, although the formulation clearly allows a departure from strict similarity in terms of width/thickness ratio etc. If the width, thickness or diameter is fixed by product or practical constraints, insistence on proportional specimen types implies that a variable gauge length would be required and 'Non-proportional' specimens accommodate practical convenience given that variable length extensometers are difficult to keep in calibration. Various comparisons of different international standard specimen types have been carried out (Sonne (1983) and Figure 36 Effect of Test Specimen Type on the Elongation of Sheet Steel (Sonne et al (1983)

showing that substantial variations in fracture elongation are found. Even in the case of a fixed constant, different specimen dimensions and forms may lead to slightly different elongation values.

6.2 Proportional test specimens

Increasing the proportionality constant has been found to decrease elongation in cold-rolled mild steel and brass (Helms (1975)), Figure 37 and Vasin (1975) , Figure 38, stainless steel (Matthew, M.D. (1985), Figure 39 and various aluminium alloys (Sato (1973),Figure 40. This effect is to be expected in general as shorter gauge length specimens will be more influenced by necking.

The effects of width/thickness ratio in rectangular cross-sections for a constant proportionality constant is shown in Figure 41 – Figure 43 taken from work by Grumbach et al (1977) and Misiolek (1964) . In some materials, increasing the width has the effect of decreasing elongation, as the transverse constraint in a wide specimen has an influence through yield criteria. This effect may also be apparent in the fracture angle and type (ductile/brittle) as shown by Hsu et al (1965) Figure 44.

Various comparisons of cylindrical and rectangular specimens have been made (Tomenko et al (1979) and Poner et al (1975)) and these suggest that the area equivalence principle is valid, especially for square section specimens, although variations may occur due to deficiencies in alignment or sampling variations for the different shapes.

6.3 Non-proportional test specimens

The main reason for such specimens is to maintain a constant gauge length. Several investigations can be found in the literature (Pretnar and Yebuah (1987), Sonne et al (1983)) and, in general, increasing the gauge length or the parallel length usually decreases the measured elongation for reasons already given above.

Tables to allow comparison of test results from specimens having different gauge lengths have been used for many years. These are based on the Oliver (1928) formula which relates the elongations A_1 and A_2 of different specimens by the equation: -

$$\frac{A_1}{A_2} = \left[\frac{L_{02}}{L_{01}} \sqrt{\frac{S_{01}}{S_{02}}} \right]^{0.4}$$

This formula does not, however, take into account differences in parallel length.

6.4 Testing machine factors

Most studies of ductility have concentrated on the specimen geometry and the influence of machine design, grips, alignment and so on may often be taken for granted. Machine control and frame stiffness can also have a profound effect on

ductility, particularly in the case of reduction in area measurements, as the final necking and fracture phase of a test is characterised by instability. A machine with a stiff frame and a rapid strain rate control response will be capable of unloading the specimen in a progressive manner to inhibit the onset of instability and may therefore achieve a greater reduction in area of the specimen and a higher measured elongation. This has clearly been demonstrated by the work of Markowski (1991) who built a special research machine with a very stiff inner frame which did not unload energy in an uncontrolled manner into a testpiece at the onset of necking, and was hence able to draw testpieces down to a very fine point with commensurate very high values of ductility compared with considerably lower values measured on conventional tensile testing machines, Figure 45. Thus it may be inferred that ductility is not an absolute inherent material property since it is highly dependent upon the testing machine, the testing conditions and the form of the testpiece. The machine developed by Markowski has subsequently been developed and characterised by colleagues at BAM, (Seiffert et al, 2004 and Subaric-leitis et al , 2004) and is currently being used as a stiff frame for indentation hardness measurements.

7. Speed & Control of Testing

7.1 Background

It has long been understood that the strength properties exhibited by materials may depend as much on the testing systems and procedures used as on the materials themselves. David Kirkaldy (1862) identified the role of strain rate 140 years ago, despite using equipment which would be considered primitive by today's standards. In the context of testing rate, he asserted that "*It is absolutely necessary to correctly know the exact conditions under which any tests are made before we can equitably compare results from different quarters*". Professor Archibald Barr (1905) demonstrated the effect of variable applied stressing rate in an illustrated lecture given in Glasgow. He used an ingenious dead-weight autographic wire testing machine Figure 46, to test various materials and concluded *inter alia* that it would be "*ridiculous to quote yield strength to several decimal places*" as "*the apparent mechanical properties of materials depend greatly on their prior treatment and manner of testing*". J L M Morrison (1934) argued, in the conclusions of a study where different testing speeds had been used in a series of tests, that "*If it is agreed that the yield stress of the materials is of paramount importance it is obvious that the definition of the yield must be standardised and the method of measuring it above suspicion*". It seems that this basic argument has to be revisited over and over again as new testing technology is introduced in succeeding generations.

There are in fact two separate questions concerning the effects of testing speed and control:

- How accurately can a given machine and test set up control the specimen strain rate?
- How much does variation in the strain rate influence the results for a given material?

7.2 Developments in Testing Machine Technology

It is useful to briefly review the development of testing machine systems in the light of the above understanding, as it is clear that there is always interaction between the mechanics of the machine and the material under test.

Many of the testing machines cited in 19th Century literature (eg Kirkaldy, Bauschinger) could apply large forces through hydraulic actuators and the force measurement systems were usually based on balance beams and jockey weights. Mechanical extensometers were used in some cases, but this dictated a very slow testing speed to give sufficient time to make observations. Yielding was detected in general by a spontaneous reduction in load, resulting in an obvious drop of the balance beam when the extension rate of the specimen exceeded the displacement rate of the actuator. The testing rates at critical strength points, either in terms of strain rate or loading rate, could not therefore be held constant or well controlled.

In the case of testing machines with stiff testing frames and load trains (as was the case in Kirkaldy's Southwark machine) these yield drops would be clearly marked and a skilled operator would have been able to check the acceleration of strain and maintain good control, albeit at a slow speed. If the load were applied through a dead-weight system, either directly as in the Barr demonstration apparatus, or through a lever system, rapid straining would occur post-yield for a material exhibiting upper and lower yield strength. There would also be no possibility of controlling the system beyond the point where maximum force was reached, ie into the necking regime.

Early designs of hydraulic and lever machines were still in use for routine testing until the late 1960's, at least. Therefore, testing standards until that time were obliged to include suitable yield detection procedures based on "drop of beam" or alternatively, "drop of pointer" in cases where the load indication was based on a pendulum-weighted pointer system.

During the first half of the 20th Century many mechanical improvements to systems were made, including motorised screw driven systems to apply the load, greater precision in flow control for hydraulic systems and improved force measurement devices which facilitated continuous measurement. Various mechanisms were often provided to generate autographic load/extension charts. These developments had the potential to improve procedures, by allowing a 'hands-off' approach during the test and by removing some of the variables associated with the preferences of the operator. They also made it possible to

speed up tests and in some cases, to include autographic extensometry. However, as always, these apparently improved systems were more open to misuse, for example, if very high straining speeds were applied. Capability to control the rate of testing, especially through a yield drop event, remained poor until the advent of servo systems, first of all on screw driven machines and then on hydraulic systems (ca 1970).

Rate control problems in testing arise from at least three main sources.

1. The first is that the specimen forms an integral element of the control system (whether manual or servo) and its compliance varies throughout a typical test. In particular, compliance reverses sign in the necking plasticity stage and even more suddenly during upper/lower yield transitions or other events characterised by apparent slipping behaviour.
2. Specimen-mounted extensometers should facilitate good rate control, as they provide a direct reading of specimen strain. But they can be troublesome to apply and may not give a reliable signal. They may also have to be removed from the specimen before the failure point of the test has been reached.
3. Specimen strain may be inferred from signals based on crosshead movement or overall extension, which provide a more robust measurement. However such information will include extensions arising from frame deflections and load train stretch, which are not relevant to the behaviour of the specimen. If the machine is particularly compliant relative to the specimen and a fixed overall extension rate is set, the extension rate on the specimen will increase substantially when the elastic limit point of the test is passed.

Testing standards developed in the context of 'open-loop' machines attempted to deal with these rate control problems by applying procedures that live on to some extent in current testing standards, although they may now be redundant or even anomalous. For example:

- The '**machine hardness**' approach, which was designed to deal with the compliant machine problem. This depended on a preliminary procedure whereby the compliance of an individual machine was inferred from a sample test and used to determine a suitable extension rate that would restrict the test specimen strain rate to the desired range. UK Standard BS 4759: 1971 was issued to provide such a "hardness" measurement procedure. This approach to rate control was also recommended in the relevant DIN testing standard, although in that case, the testing machine manufacturer was expected to supply the requisite 'hardness' value. There is little evidence that this procedure was widely used. The UK compliance standard was later withdrawn and the concept of incorporating a rate adjustment based on such determinations was not included in later standards.
- The '**controlled stressing rate**' procedure set a maximum rate for the stress increase in the elastic loading part of the test and advised that the machine controls should not be further altered, once this rate had been established.

This was based on two premises. The first was that the compliance of the specimen and the machine should both be more or less constant and positive during the elastic loading phase and, therefore, stable conditions could be established to set the rate. The second was that the load measurement system was considered to provide a more reliable indication of the elastic strain rate experienced by the specimen than crosshead movement or the output from an extensometer, if available. However, accurate control of the elastic strain rate does not ensure accuracy in subsequent stages of the test, which are in any case more sensitive to strain rate. Also, there is not normally a technological justification in a materials science sense in applying a controlled stressing rate (unless in the special case where the aim is to simulate a specific structural application involving linearly increasing load with time).

From about 1970 to the present day, the technology of testing machines used for tensile property evaluation has been dominated by the development of servo-controlled systems, although there have also been many concurrent developments and valuable improvements in the mechanical and parameter measurement aspects. The increasing requirements for testing in the context of fatigue, fracture mechanics and component testing has promoted the development of systems with increased dynamic performance, which has been beneficial for tensile testing in terms of improved control response. McEnteggart and Lohr (1995) have summarised the features of the main types of universal testing machine in common use at that time. These include electromechanical systems where a moving crosshead is driven by a servomotor through lead screws Figure 47; servohydraulic systems, driven by double-acting hydraulic actuators and controlled by servo-valves Figure 48; and electric actuator machines, where the single hydraulic ram is replaced by a recirculating ball screw driven by a servomotor. The different types of machines have aptitudes for different forms of materials test (dynamic, creep, fatigue etc) but all are regularly used also for tensile testing.

Servocontrol capability has also developed substantially over three decades. Early machines were based on single mode feedback and control (eg strain control) and analogue electronics. In the early 1980's, a number of manufacturers produced hybrid systems whereby the controller was analogue-based but mode selection, setting of rates and monitoring of signals were addressed through digital electronics. Finally, in the 1990's, the advent of fast digital signal processors and PCs led to the introduction of digital controllers and command interfacing from Personal Computers, Figure 49. Hinton (1995) has described the capabilities and implications of these systems in detail.

The latest versions of servo-controlled machines are extremely versatile, therefore, and are capable in principle of maintaining steady testing rates and of changing control mode during a test, as often as desired. The presence of a PC in the system means that there is a capability for the implementation of complex algorithms in the command, control and data processing structure of the

machine. One of the most important areas where such capabilities are more than essential is related to the problem of matching the dynamic characteristics of the control system to the test piece responses. In earlier hybrid or digital systems, there remained a requirement on the operator to adjust or 'tune' the controller to the anticipated characteristics of the test and this can be more than a trivial operation. The latest systems include 'adaptive' control functions in one form or another and these should assist operators to achieve stable test conditions.

Notwithstanding the huge improvements that have been made to the capabilities of modern testing machines with respect to the control of specified parameters such as rate of testing, the three problem areas concerning rate control identified earlier are still significant. The reason is that they arise from fundamental weaknesses of the interaction between the mechanics of the machines (including the instrumentation) and the control systems. The most acute of these relates to specimen-mounted extensometers. If the extensometer fails to provide a relevant signal, due to slippage of the knife-edges, bending of the specimen or inhomogeneous behaviour of the material, for example, it will send back a spurious message to the controller, which will then implement an inappropriate action. A significant instance of such a problem arises frequently where the extensometer covers only a small proportion of the parallel length of the test specimen and yielding occurs outside that length. The strain rate 'seen' by the extensometer may then *reduce* (while it is increasing in the true gauge length) and an erroneous command to increase rate will be given. It is also salutary to realise that the extensometer provides only an *average* reading of the strain within its gauge length and there may be substantial divergences from this average within that length, due, for example, to Lüders band formation. Figure 50 shows the strains measured by several strain gauges mounted within the parallel length of a cylindrical test specimen of carbon steel, during the elastic and yielding phase of a tensile test carried out under standard rate conditions.

An alternative approach to strain rate control in situations where simple displacement control is expected to be problematic, due to machine compliance effects for example, has been advocated by McEnteggart and Lohr (1995), under the description of 'outer loop control'. (Figure 51, taken from Hinton (1995) shows a block diagram for an outer loop control system, which might be used to control fatigue cycle amplitude.) In the strain rate control context, the *rate* output from the extensometer (rather than the absolute value) is used to modify the input demand for displacement rate and would therefore correct the crosshead speed to maintain the desired strain rate. This still depends on there being a valid strain output, but it is alleged to be less sensitive to spurious feedback from the extensometer transducer.

The increasing power and speed of computers and software algorithms hold out the prospect of increasingly 'intelligent' control of systems. These might recognise deficiencies in extensometer behaviour or frame/grip compliance as

described earlier and take appropriate action to control the movement of the machine in an optimum manner, to make best use of the available feedback signals.

This section on control systems concludes with the observation that certain simple capabilities of modern systems to *analyse* the behaviour of testing systems are much under-used. It is clear that strain rate has a critical influence on the behaviour of materials under test and it has become a relatively simple matter to monitor and record this parameter throughout a routine test. If this were to be specified in appropriate standards, it would be possible to respond positively to Kirkaldy's far-sighted exhortation to "*correctly know the exact conditions under which any tests are made*" so that "*we can equitably compare results from different quarters*".

7.3 Reported effects of testing rate on properties

7.3.1 Results before the introduction of servo-controlled machines (before 1970)

The wealth of data in the literature on the effect of testing rate on different materials is not easy to apply to modern conditions. The primary reason is that in most of the studies, the *actual* testing rates at the points of critical determination were not always accurately controlled or even measurable with the certainty that is now achievable with modern systems. Carbon steel constitutes the most common example of a strain rate sensitive material, especially with respect to lower yield strength and there have been many generic studies that can be analysed to show that this property is not independent of testing conditions. Krisch and Lakschmanan (1970) published data covering 22 steels produced in Germany, tested over two decades change in strain rate Figure 52. This showed sensitivity of the lower yield strength to be 10.2 MPa per decade strain rate increase. Johnson and Murray (1966) published data from 18 UK steels Figure 53, showing a similar sensitivity of 9.8 MPa per decade. These samples included three carbon steels, six casts of low-alloy, high-temperature steels, four general engineering alloy steels and five austenitic high-temperature steels, about half of the results being obtained at elevated temperature. Johnson (1967) collated international data covering 1,000 test specimens and 21 laboratories in five countries, which can be analysed to show an even greater sensitivity of 13.7 MPa per decade Figure 54. (The steeper slope in this case probably reflects the wider provenance of data and greater variations in testing conditions.) These tests were carried out mostly on hydraulic or screw driven machines where the strain rate control would have been better than the older balance beam machines, but was nevertheless of somewhat variable quality. Johnson observed, significantly, that many different forms of stress/strain curve were found in this survey and that these differences were '*associated with particular types of testing machine used in different countries and particular testing techniques employed*'.

7.3.2 Results from studies including servo-controlled machines

The order of strain rate sensitivity found in the pre-1970's tests discussed above was confirmed in a more recent study carried out on a single steel across 9 machines, comprising open-loop mechanical and hydraulic systems, together with servo-controlled machines under alternative crosshead or extensometer rate control (Gray and Sharp (1987)). A strain rate sensitivity of 10.2 MPa per decade was found for lower yield strength, Figure 55, accompanied by substantial scatter, corresponding to ± 19 MPa. When the *same* steel was tested under tight strain rate control, delivered by an extensometer feedback system, the sensitivity reduced to 6.6 MPa per decade, Figure 56. Actual strain rates were recorded in all tests and these results revealed, as in Figure 56, that the tests using open-loop machines frequently exceeded the maximum target strain rate and that much of the scatter was due to results from the open-loop and displacement-controlled tests. Note that these strain rates were *as measured*, whereas in many studies the quoted strain rates are *as set*. This could lead to an even greater apparent strain rate sensitivity, as the actual rates at the point of yield would then be much greater than the set rates. It is also worth noting that the variation in yield due to strain rate is an *absolute* variation, rather than a percentage variation relative to each typical mean value.

Another point that emerged from this study was that greater variations in yield strength values tended to occur at higher testing speeds. The reasons for this were found to be related to instability during the transition from the upper to the lower yield strength and the performance of different control systems through this stage. Figure 57, in which results obtained using servo-controlled machines are collated, shows that the magnitude of the transition step increases with strain rate. Figure 58, which shows results for open-loop machines, shows much-increased scatter and highlights the consequences of poor control at the point of transition. This is all very unfortunate from a practical point of view, as it means that if the maximum strain rates permitted in the current standard are applied (which is desirable for production reasons) and the machine is not well-controlled, higher apparent yield strengths will be recorded, together with increased scatter.

Most of the tests cited above were carried out on profiled, generously dimensioned, cylindrical specimens with positive end fixings. This is an ideal configuration, as indicated in the section on gripping systems, as the undesirable effects of poor alignment are reduced and the testing rate accelerations associated with 'soft' machines are also minimised. Sheet specimens present various challenges, on the other hand, with respect to extensometry and the control of testing rate. A recent set of test results reported by Aegerter et al (2001) provide a range of data measured on thin sheet materials, where the outcomes of different control strategies and the effects of different testing rates and machine compliances can be analysed. (Some of these results have already been cited in the context of gripping systems.) Servo control was used in all

cases, either of crosshead displacement or extensometer strain. The control strategies were differentiated, depending on whether 0.2% proof strength, or upper/lower yield strength, as appropriate.

In the $R_{p0.2}$ case, the control alternatives were as follows:

- A. Crosshead displacement rates were set to achieve the correct linear elastic loading rates at the extremes of the stressing rates permitted by the current EN 10002 standard and these rates were not then altered through the determination of $R_{p0.2}$ (ie following the 'stressing rate' procedure described earlier and accepting the inevitable variable increase in specimen strain rate, depending on machine compliance).
- B. The upper extreme of the stressing rate was used in the linear elastic regime but the displacement rate was then reduced by almost an order of magnitude to a level which would achieve the maximum allowable strain rate in the specimen. (Note that this would require prior calibration for each material and for the alternative machine compliances.)
- C. Closed loop strain control at the lower extreme of the strain rates permitted by the standard.

The results depended somewhat on the individual materials (shown earlier in Figures 30-33). In the case of the strain rate sensitive steels DC05 and DC06, a decade increase in strain rate at the point of proof strength determination produced a 10-15 MPa increase in apparent strength, which compares with earlier findings. The finding that gives more concern, arises from comparison of the result from the lowest 'stressing rate' with the highest strain rate, resulting in an $R_{p0.2}$ increase of 23.2 MPa, compared to a mean value for the material of only 134 MPa. It should also be appreciated that the upper value in this case was obtained at a *controlled* strain rate, due to the use of servocontrol and the prior calibration procedure. The possibility exists that the strain rate might be even higher in a case where a 'soft' machine is used without proper servocontrol and calibration.

In the case of tests on materials exhibiting yield drop behaviour, control strategies A,B,C were again used, but in strategy A, the strain rate was reduced following determination of the upper yield, in order to achieve the upper and lower extremes of the standard as required for the determination of lower yield. In strategy C, the lower strain rate option was used until the determination of upper yield and then the rate was increased to the maximum level permitted for the determination of lower yield - all in closed loop extensometer control.

These results showed substantially greater variability, even for closed loop extensometer control, and the results obtained in the more compliant wedge grip configuration tended to be the most variable of all. Lower yield strength sensitivity to strain rate corresponding to 8-10 MPa per decade was again found for steels. However, the overall variability between the lowest and the highest

results was not much greater than that, perhaps because the strain rate through the lower yield phase in the A strategy was controlled.

The upper yield strengths reported in this study also deserve comment, although this property is less often regarded as a significant material property for engineering purposes. It is seen that the R_{eH} values measured in this study are highly sensitive to initial strain rate and highest variability is associated with the wedge grip loading configuration. This is not an entirely new finding, as it was reported at least by Johnson and Murray (1966), Johnson (1967) and Lange (1972). In the study by Gray and Sharp, reported earlier, a strong effect of machine control is evident Figure 56. Extensometer controlled tests showed a sensitivity of 12.3 MPa per decade, whereas, for other forms of control (including displacement-based servo control) the sensitivity was 15.4 MPa per decade, with a higher mean level and a wider scatter band.

Within the range of non-extensometer-controlled results, there was clear evidence that less scatter and lower strain rate sensitivity was associated with the tests carried out on closed-loop displacement controlled systems (also shown in the Aegerter et al (2001) study). The reasons for these differences need to be explained, as accepted wisdom in testing standards is that upper yield is simply a function of elastic loading rate, which should be simple to control, even without a servo system. The reason seems to be that the extensometer feedback signal is much more sensitive to the onset of plasticity and checks further movement of the crosshead, whereas the less sophisticated control strategies, particularly the open-loop systems, allow overshoot of the load and an apparently higher upper yield value.

The effect of strain rate on tensile strength was also examined by Gray and Sharp (1987) in the study cited earlier Figure 60. All of the results taken together appeared to show a small increase in tensile strength with strain rate, but once again, it can be seen that this effect is mostly associated with the open loop machines.

8. Uncertainty of Measurement

8.1 Introduction

This Section provides guidance on how to estimate the uncertainty of measurement when undertaking Room Temperature Tensile Testing in accordance with the European Standard EN 10002 Part 1. It includes the basis of an 'Informative' (i.e. non-mandatory) annex for inclusion in a possible revision of the Standard. It has been based upon an approach for estimating the uncertainty of measurement using an "error budget" concept using the tolerances specified in the testing and calibration standards which has been published elsewhere (Loveday, (1992)) and which was subsequently expanded to form the basis of the informative annex for ISO 6892 (1995). Appendix 3, presented here, has now been

revised to follow more closely the approach for estimating the uncertainty of measurement outlined in the ISO TAG4 'Guide to the expression of uncertainty in measurement.' (1994). Outline details of how to prepare an Uncertainty Budget for Room Temperature Tensile Testing are shown in Appendix 3, however further information on the estimation of uncertainty is now available in a '*Beginners Guide*' (Bell,(1999)) and in '*Estimating Uncertainties in Testing*',(Birch,. (2001)).

The approach adopted here for the Tensile Uncertainty Budget (Loveday, (1999)) is similar to that proposed for a creep testing uncertainty budget used in association with the Creep Certified Reference Material, CRM 425, (Loveday, (1996)). Comprehensive statements of uncertainty have also now been published as part of the EU Funded project '*Uncert*' (Kandil, et al (2000)), and consideration is now underway to issue three uncertainty documents covering a) Low Cycle Fatigue, b) Creep and c) Tensile Testing as CEN endorsed Technical Workshop Agreements.

8.2 Discussion

It should be appreciated that it is not possible to calculate a single value for the measurement uncertainty for room temperature tensile testing for all materials since different materials exhibit different response characteristics to some of the specified control parameters, e.g. straining rate or stressing rate, and at present only limited systematic data are available over the testing parameters tolerance ranges specified in the Standard. Estimates of the measurement uncertainty for yield stress are given in the Annex for five materials, viz. two ferritic steels, an austenitic stainless steel and two nickel base alloys using material property data published elsewhere, (Loveday (1992)). The 'Expanded Uncertainty' calculated at approximately the 95% confidence level are shown graphically in Appendix 3, Figure A3., with a simple power law trend line plotted through the data. Thus it can be seen that the estimated measurement uncertainties range from $\pm 2.3\%$ up to $\pm 4.6\%$ at approximately the 95% confidence level. Hence two laboratories testing in accordance with EN10002 Part1, but controlling their machines at the extreme ends of the permitted tolerance ranges, may produce tensile results with differences up to 4.6 - 9.2% depending upon the material being tested. It should be noted that the estimated uncertainties do not take into account the inherent scatter attributable to material inhomogeneity.

9. Round Robin Experiments

9.1 . Inter-laboratory Scatter

Results from a number of laboratory inter-comparison exercises have been reported in the literature, and results from such exercises were previously summarised in an informative annex in EN10002 Part 1, and subsequently in ISO 6892, and are presented here in graphical form as shown in Appendix 3 Figure A3.2. An indication of the typical scatter in tensile test results for a variety of materials that have been reported during laboratory inter-comparison exercises, which include both material scatter and measurement uncertainty are shown in Tables 8.1 – 8.4, (see below). The results for the **Reproducibility** are expressed in

% calculated by multiplying by 2 the standard deviation for the respective parameter, e.g. R_p , R_m etc. and dividing the result by the mean value of the parameter, thereby giving values of reproducibility which represent the 95% confidence level, in accordance with the recommendations given in the GUM, and which may be directly compared with the Expanded Uncertainty values calculated by alternative methods. The data are shown in graphs in Appendix 3. The original tables were incorporated into EN 10002 Part 1, and subsequently in ISO 6892; here it has been expanded to include the data from a recent European Aluminium Association (EAA) round robin on AA 6016 and AA5182 (Aegerter *et al* 2003) together with data from the TENSTAND project, Work Package 4.

It should be noted that in general during inter-comparison exercises all the laboratories aim to carry out the testing under similar conditions, i.e. the strain rate is at a specified value rather than anywhere in the range permitted in the Standard, and the material tested is usually selected from single bars or taken from adjacent pieces of plate so as to minimise the scatter attributable to material inhomogeneity.

In the case of the Nimonic 75 which has been characterised as a Certified Reference Material, (CRM661), test-pieces were tested from bars representing the extreme ends of the material property spectrum of the two hundred bars obtained from the one ton master melt. (Ingelbrecht & Loveday,(2000)). If the inter-laboratory reproducibility for individual bars were considered, then the reproducibility for any parameter was typically a factor of 4 smaller than that for the entire bar stock, i.e. the Yield Strength reproducibility for a single bar was ~1% whereas for the entire bar stock it was ~ 4.0%.

Material	Code	Yield or Proof Strength MPa	Reproducibility +/- U_E, %	Reference
Aluminium				
	AA5754	105.7	3.2	Tenstand WP4, 2004
	AA5182-O	126.4	1.9	Aegerter et al, 2003
	AA6016-T4	127.2	2.2	Aegerter et al, 2003
	EC-H 19	158.4	4.1	ASTM Report, 1994
	2024-T 351	362.9	3.0	ASTM Report, 1994
Steel				
Sheet Low Carbon, Plate.	DX56	162.0	4.6	Tenstand WP4, 2004
	HR3	228.6	8.2	Roesch et al, 1993.
Sheet	ZStE 180	267.1	9.9	Tenstand WP4, 2004
AISI 105	P245GH	367.4	5.0	Roesch et al, 1993.
	C22	402.4	4.9	ASTM Report, 1994.
Plate	S355	427.6	6.1	Tenstand WP4, 2004
Austenitic S S	SS316L	230.7	6.9	Tenstand WP4, 2004
Austenitic S S	X2CrNi18-10	303.8	6.5	Roesch et al, 1993.
Austenitic S S	X2CrNiMo18-10	353.3	7.8	Roesch et al, 1993.
AISI 316.	X5CrNiMo17-12-2	480.1	8.1	ASTM Report, 1994.
Martensitic S S	X12Cr13	967.5	3.2	ASTM Report, 1994
High Strength.	30NiCrMo16	1039.9	2.0	Roesch et al, 1993.
Nickel Alloys				
INCONEL 600	NiCr15Fe8	268.3	4.4	ASTM Report, 1994.
Nimonic 75	(CRM661)	298.1	4.0	Ingelbrecht & Loveday, 2000
Nimonic 75	(CRM661)	302.1	3.6	Tenstand WP4, 2004

**Table 8.1: Yield Strengths (0.2% Proof Strengths or Upper Yield Strengths):
Reproducibility from laboratory Inter-comparison exercises.**

Material	Code	Tensile Strength MPa	Reproducibility +/- U _E , %	Reference
Aluminium				
	AA5754	212.3	4.7	Tenstand WP4, 2004
	AA5182-O	275,2	1.4	Aegerter et al, 2003
	AA6016-T4	228,3	1.8	Aegerter et al, 2003
	EC-H 19	176.9	4.9	ASTM Report, 1994
	2024-T 351	491.3	2.7	ASTM Report, 1994
Steel				
Sheet	DX56	301.1	5.0	Tenstand WP4, 2004
Low Carbon, Plate.	HR3	335.2	5.0	Roesch et al, 1993.
Sheet	ZStE 180	315.3	4.2	Tenstand WP4, 2004
AISI 105	Fe510C	552.4	2.0	Roesch et al, 1993.
	C22	596.9	2.8	ASTM Report, 1994.
Plate	S355	564.9	2.4	Tenstand WP4, 2004
Austenitic S S	SS316L	568.7	4.1	Tenstand WP4, 2004
Austenitic S S	X2CrNi18-10	594.0	3.0	Roesch et al, 1993.
Austenitic S S	X2CrNiMo18-10	622.5	3.0	Roesch et al, 1993.
AISI 316.	X7CrNiMo17-12-2	694.6	2.4	ASTM Report, 1994.
Martensitic S S	X12Cr13	1253	1.3	ASTM Report, 1994
High Strength.	30NiCrMo16	1167.8	1.5	Roesch et al, 1993.
Nickel Alloys				
INCONEL 600	NiCr15Fe8	695.9	1.4	ASTM Report, 1994
Nimonic 75	(CRM661)	749.6	1.9	Ingelbrecht & Loveday, 2000
Nimonic 75	(CRM661)	754.2	1.3	Tenstand WP4, 2004

**Table 8.2 (above) Tensile Strengths, R_m:
Reproducibility from laboratory Inter-comparison exercises.**

Material	Code	Reduction In Area, Z %	Reproducibility +/- U _E , % ⁽¹⁾	Reference
Aluminium				
	EC-H 19	79.1	5.1	ASTM Report, 1994
	2024-T 351	30.3	23.7 ⁽²⁾	ASTM Report, 1994
Steel				
AISI 105	Fe510C	71.4	2.7	Roesch et al, 1993.

Austenitic S S AISI 316.	C22	65.6	3.8	ASTM Report, 1994.
	X2CrNiMo18-10 X5CrNiMo17-12-2	77.9 71.5	5.6 4.5	Roesch et al, 1993. ASTM Report, 1994.
Martensitic S S High Strength.	X12Cr13	50,5	15.6 ⁽²⁾	ASTM Report, 1994
	30NiCrMo16	65.6	3.2	Roesch et al, 1993.
Nickel Alloys				
INCONEL 600	NiCr15Fe8	59.3	2.4	ASTM Report, 1994.
Nimonic 75	(CRM661)	59.0	8.8	Ingelbrecht & Loveday,2000.

Table 8.3 (above) Reduction in Area, Z:

Reproducibility from laboratory Inter-comparison exercises.

- (1) **Note 1.** The reproducibility is expressed as a percentage of the respective mean value of Z for the given material; thus for the 2024 –T 351 Aluminium the absolute value of Z is 30.3+/- 7.2 %.
- (2) **Note 2.** Some of the values of reproducibility may appear to be relatively high; such values probably indicate the difficulty of reliably measuring the dimensions of the testpiece in the necked region of the fracture. For thin sheet testpieces the uncertainty of measurement of the thickness of the testpiece may be large, Likewise the measurement of the diameter or thickness of a testpiece in the necked region is highly dependent upon the skill and experience of the operator.

Material	Code	Elongation At Fracture, A %	Reproducibility +/- U _E , % ⁽¹⁾	Reference
Aluminium				
	AA5754	27.9	13.3	Tenstand WP4, 2004
	AA5182-O	26,6	10.6	Aegerter et al 2003
	AA6016-T4	25,9	8.4	Aegerter et al 2003
	EC-H 19	14.6	9.1	ASTM Report, 1994
	2024-T 351	18.0	18.9 ⁽¹⁾	ASTM Report, 1994
Steel				
Sheet	DX56	45.2	12.4	Tenstand WP4, 2004
Low Carbon, Plate.	HR3	38.4	13.8	Roesch et al,1 993.
Sheet	ZStE 180	40.5	12.7	Tenstand WP4, 2004
AISI 105	Fe510C	31.4	14	Roesch et al, 1993.
	C22	25.6	10.1	ASTM Report, 1994.
Plate	S355	28.5	17.7	Tenstand WP4, 2004
Austenitic S S	SS316L	60.1	27.6	Tenstand WP4, 2004
Austenitic S S	X2CrNi18-10	52.5	12.6	Roesch et al, 1993.
Austenitic S S	X2CrNiMo18-10	51.9	12.7	Roesch et al, 1993.

AISI 316.	X5CrNiMo17-12-2	35.9	14.9	ASTM Report, 1994.
Bar	X2Cr13	12.4	15.5	ASTM Report, 1994
High Strength.	30NiCrMo16	16.7	13.3	Roesch et al, 1993.
Nickel Alloys				
INCONEL 600	NiCr15Fe8	41.6	7.7	ASTM Report, 1994.
Nimonic 75	(CRM661)	41.0	3.3	Ingelbrecht & Loveday, 2000
Nimonic 75	(CRM661)	41.0	5.9	Tenstand WP4, 2004

**Table 8.4:(above) Elongation after fracture:
Reproducibility from laboratory Inter-comparison exercises.**

Note 1. The reproducibility is expressed as a percentage of the respective mean value of A for the given material; thus for the 2024 –T 351 Aluminium the absolute value of A is 18.0 +/-3.4 %

10. Measuring Systems & Data Recording

Early machines relied purely on visual observations of the maximum load sustained by a material as indicated by the position of a jockey weight on a steel yard, or the position of a pointer on a dial. Autographic recording was introduced shortly after the turn of the 20th century. In the ~1960's onwards commercial machines were supplied with chart recorders and it was usually assumed that these devices had a sufficient response to faithfully plot the response of the testpiece to the imposed deformation. It has only been relatively recently that it is essential to specify the data capture baud rate for digital data acquisition systems embodied in computers to ensure that sufficient points are collected to allow appropriate interpolation and curve fitting to peaks and transients

The issue of data sampling frequency was addressed in Annex A of EN20002 Part 1 (2001) where a following formula was given to enable a minimum baud rate to be calculated for the data acquisition rate :

$$f_{\min} = \frac{\dot{\sigma}}{R_{eH} \times q} \times 100$$

where

f_{\min} is the minimum sampling frequency in s^{-1} ;

$\dot{\sigma}$ is the stress rate in $MPa s^{-1}$;

R_{eH} is the upper yield strength in MPa ;

q is the relative accuracy error of the machine (according to EN ISO 7500 –1)

It should be noted that relationship is likely to be modified in the forthcoming revision of the standard when straining rate will be the preferred mode of control,

$$f_{\min} = \frac{\dot{\varepsilon} \times E}{R_{eH} \times q} \times 100$$

where $\dot{\varepsilon}$ is the strain rate in s^{-1} ;

and E is the modulus of elasticity in MPa ; and the other symbols are as above.

The above relationships typically show that data recording rates need to be ~ 5 – 50Hz, and could be as high as ~100Hz for the highest straining rates specified in the standard, however such rates are well within the capabilities of modern computer data acquisition systems, and should enable transients to be recorded. However it should be noted that at high data capture rates the data files become very large, and computer buffer stores can become overloaded; thus it is sensible to consider some means of data reduction for those parts of the stress–strain curve where only small changes in the slope of the curve are being observed.

11. Other Issues

11.1 Software Validation

The majority of tensile testing machines are now computer controlled, and indeed the results of the tensile test are usually automatically processed by dedicated software without interaction from the testing machine operator. The informative annex A '*Recommendations concerning the use of computer controlled tensile testing machines*' in the current issue of EN 100002 Part 1 gives guidance on specifying data capture rate and other aspects of testing associated with computer controlled tensile testing. The need now arises therefore to validate tensile test software so that the operators may have confidence in the results produced during testing. Moreover such validation will in future probably need to become an integral part of the calibration of the testing machine and will also be needed for accreditation purposes. In principle this is a generic problem that will need to be addressed by the majority of testing machines used to determine materials properties as they become increasingly dependent on computers, both for control and processing of results, whether it is an impact testing machine, a fracture toughness testing machine, a fatigue machine or a tensile testing machine.

In America the ASTM Standards committee E08.03.04 - Data Acquisition Task Group is currently working on producing a draft standard entitled '*Standard Guide for Evaluating Software used to Calculate Mechanical Properties of Materials*' which requires the various standard's sub-committees responsible for individual

testing standards to produce ASCII data files representing particular tests with agreed values of the designated material properties. Such an approach has already been used within a European Funded project where an agreed ASCII data file was used to compare and hence validate the results associated with the development of the standard concerning Charpy Instrumented Impact Testing (Varma & Loveday, 2002). A similar approach is being adopted within the EU funded project TENSTAND, where a series of ASCII data files have been prepared representing a typical tensile characteristics of a variety of industrially important materials. Data files have been prepared at two different data capture (baud) rates of 5 & 50 Hz and analysed by a number of different organisations, both industrial and academic, together with testing machine manufacturers. The results of this inter-comparison are currently being collated and analysed and will be published shortly.

It should be appreciated that use of ASCII data files in this manner is not primarily concerned with conventional validation of software in absolute terms as a rigorous analysis of lines of code, but in the pragmatic sense of demonstrating that the underlying algorithms used by the testing machine manufacturers to interpolate or calculate the material properties give comparable answers to those determined by manual analysis of the analogue graphs.

The concept behind this approach is shown schematically in Figure 61, prepared by Prof. R. D Lohr as part of the TENSTAND project. It should be noted that considerable time and effort was devoted to agreeing the format of the ASCII data files and their associated header data, so that commercial tensile software could recognise the appropriate data streams and derive the require tensile parameters. Suitable computer based data files representing typical tensile curves of ferritic and austenitic steels having upper and lower yield strength characteristics and monotonic yielding, and characteristics of typical non ferrous alloys, including the Room Temperature Tensile Reference Material, CRM 661, a nickel based alloy, Nimonic 75 have been prepared. Some mathematically generated files, with different noise levels, have also been included in the analysis. The correct force / displacement values for the various ASCII files were agreed by manual inspection of the raw data files by a working group, rather than accepting a statistical average value determined in the round robin exercise, which is unlike the procedure normally undertaken when determining agreed certified values for reference materials. The ASCII data files and the agreed tensile parameters developed in the TENSTAND project will be made available for software validation purposes, on the TENSTAND web site, together with the results of the inter-comparison exercise.

11.2 Modulus Measurement

Standard requires the generation of a straight line with a given offset parallel to the linear region of the Stress-Strain curve as shown in Figure16. The intersect of the generated off-set line with the recorded stress -strain corresponds to the specified Proof Stress, R_p , of the material being tested, and the manner in which the testing machine software determines such intercept points data requires

validation. The slope of the linear elastic region of the curve should nominally corresponds to the Young's Modulus of the material being tested. It is rather surprising that although a reliable value of Modulus is essential for the primary design of any type of engineering component ranging from a jet engine, a bridge of any form of building structure, through to body implants such as hip or knee joints, never-the-less there is not at present a separate ISO or European Standard independently covering modulus measurement.

In reality it is difficult to determine reliable values of modulus in the tensile test unless a special high resolution side-to-side averaging extensometer is employed, and such devices are not generally suitable for covering the full range of the tensile test. If a single sided extensometer or clip gauge is employed then any slight misalignment of the testpiece can result in gross errors of the apparent modulus measurement. The errors likely to be encountered using Class 1 extensometers have been considered by Dean et al (1995), along with various other aspects of modulus measurement. An example of the scatter that is likely to be encountered in the measurement of modulus using Class 1 extensometers in the tensile test can be seen in Figure 62, where the scatter in an Inter-comparison Exercise was found to be $\sim \pm 12\%$ at the 95% confidence level for the Nimonic 75 Tensile Certified Reference Material, CRM 661. It can also be seen that by using a special high resolution side-to-side averaging extensometer the scatter may be considerably reduced (Laboratory E, Figure 62).

If the slope of the linear elastic region of the stress-strain curve is in good agreement with the conventionally accepted values of Young's Modulus, then it provides re-assurance that the testpiece is aligned well and that the extensometry is performing correctly.

For materials which exhibit non-linear elastic characteristics, such as metal matrix composites or 316 stainless steel, sophisticated curve fitting procedures are necessary to optimise the modulus line so that reliable values of proof stress may be determined (Roebuck et al 1992, Dean et al, 1995, Lord & Roebuck, 1997)

It is clear that the tensile test is not the best method for determining reliable values of Young's modulus, and other alternative methods, e.g. Impulses Excitation or Ultrasonics, are preferable (Dean et al, 1995 and Lord & Orkney, 2000).

In the TENSTAND project a separate Workpackage covered the problem of the measurement of Modulus during the Tensile test and the findings are being reported elsewhere.

11.3. Determination of tensile strain hardening exponent n and of plastic strain ratio r

11.3.1 Introduction to r and n

In the sheet metals industries, two additional parameters may be determined in the tensile test which are widely used to characterise the material's ability to be formed, or deep drawn, with out cracking. These parameters are the strain hardening exponent, n , and the plastic strain ratio, r . These parameters are particularly important in specification of sheet steels and aluminium used in the beverage and food canning sector and in the formation of body shell components for the automotive and aerospace sectors. The following section is based on a recently published paper by Aegerter *et al* (2004).

The first guidelines for the determination of the tensile strain hardening exponent or for the determination of the plastic strain ratio was published by the German "Verein Deutscher Eisenhüttenleute" (VdEh) as the Stahl-Eisen-Prüfblatt 1125 or 1126 in November 1984. On basis of this paper the ISO 10 275 (1993-02-15) for the strain hardening exponent or/and the ISO 10 113 (1991-05-01) for the plastic strain ratio were published. Modifications of these standards have recently been submitted by the German "Deutsches Institut für Normung e. V.", ("DIN"), subcommittee "NMP142" for consideration by the ISO sub-committee ISO TC164 SC2. These proposals, outlined below, are based on industrial practice and are endorsed by a project group of the European Aluminium Association (EAA-GTP WG1), mainly following the method developed and used by VAW aluminium AG, (now Hydro Aluminium Deutschland GmbH) R & D Bonn, since 1993 [Aegerter, 1993].

11.3.2. Determination of tensile strain hardening exponent n

According to the actual standard the strain hardening exponent has to be calculated using a linear regression and the fit

$$\ln k_f = n \times \ln \varphi + \ln k \quad (1)$$

over a minimum of 5 data points out of the stress/strain curve. "When n should be determined over the whole uniform plastic range, the greatest of these strain measurement points shall be immediately prior to the strain at which the maximum force occurs, and the lower limit of these strain measurement points shall be the yield strain, for material not exhibiting yield phenomena, of the end of the yield-point extension for materials exhibiting yield phenomena"[ISO 10275]. If the number of the data points for the determination is lower than 20, they shall be distributed in accordance to a geometric progression. As long as the elastic strain is less than 10 % of the total strain, it need not to be subtracted.

In the industrial practice, most testing machines are computer controlled, which allow a mathematical processing of measured signals or an export of the raw data sets for an additional calculation with spreadsheet programs. Considering this it is recommended in the EAA test procedure to subtract the elastic part generally (the Young's modulus of aluminium is 1/3 of the modulus of steel, the elastic strain is 3 times higher) and to use all data points in the range of determination (see below) for the linear regression. Using all data points increases the accuracy of the results, especially when metals or alloys show

serrated yielding (Aluminium alloys of the series 5xxx or some brass grades). For the calculation of the true stress k_f and the true strain φ_l the following equations should be used:

$$k_f = \sigma \times (1 + \varepsilon_{pl}) \quad \text{or} \quad (2)$$

$$k_f = (F / S_0) \times ((L_0 + \Delta L) / L_0 - F / (S_0^{**} \times E)) \quad (3)$$

**first approximation, better approximation: True cross-section area:

$$S_{true} = S_0 \times L_0 / (L_0 + \Delta L) \quad (4)$$

$$\varphi_l = \ln (1 + \varepsilon_{pl}) \quad \text{or} \quad (5)$$

$$\varphi_l = \ln ((L_0 + \Delta L) / L_0 - F / (S_0^{**} \times E)) \quad (6)$$

Different determination ranges were used in the automotive industry depending of the application. The EAA-working group defined three different determination ranges which are indicated in indices, as shown in Figure 63:

- n_{4-6} : linear regression between 4 and 6 % plastic (engineering) strain ε_{pl}
- n_{10-15} : linear regression between 10 and 15 % plastic (engineering) strain ε_{pl}
- $n_{2-20/(A_g-1)}$: linear regression between 2 and 20 % plastic (engineering) strain ε_{pl} or 2 % plastic (engineering) strain ε_{pl} and $(A_g - 1\%)$, if $(A_g - 1\%) < 20\%$ resp.

The results n_{4-6} or n_{10-15} resp. are invalid, if $(A_g - 1\%)$ is smaller than 6 % or 15% resp.

11.3.3. Determination of plastic strain ratio r

For the manual determination of the plastic strain ratio acc. to ISO 10 113 a specimen has to be stretched by a defined value, the width has to be measured and the value has to be calculated acc. equation (7). For the automatic method the width change and the extension is measured continuously with special extensometers. A single extension/width pair in the chosen determination range has to be evaluated. The change of width must be homogeneous, otherwise the test is invalid.

According to the EAA-procedure a regression method is used to evaluate a larger amount of data. The basis for this are the approaches in equations (7) and (8).

$$r = \varphi_b / \varphi_s \quad (7)$$

$$0 = \varphi_l + \varphi_b + \varphi_s \quad (8)$$

Out of this a linear correlation equation (9) can be derived. Using a linear regression through the origin from φ_b over φ_l in the defined determination range the slope m will be calculated and out of the slope the r -value using equation (10).

$$\varphi_b = (-r / (1 + r)) \times \varphi_l \quad (9)$$

$$r = -m / (1 + m) \quad (10)$$

The manual methods used the plastic deformations of the specimen – the width of the specimen is measured before and after the stretching under unloaded conditions. For using the regression method the true length strain φ_l and the true width strain φ_b have to be calculated generally out of the plastic strains. They have to be calculated by using the equations (5) or (6) respectively, as well as equations (11) and (12) or (13) respectively. The Poisson's ratio $\nu = 0.33$ has to be used for Aluminium.

$$\varphi_b = \ln (b_{pl} / b_0) \quad (11)$$

$$b_{pl} = b_0 - \Delta b + (b_0 \times \nu \times \sigma / E) \quad (12)$$

$$\varphi_b = \ln ((b_0 - \Delta b + (b_0 \times \nu \times F / (S_0^{**} \times E))) / b_0) \quad (13)$$

In the same way as for the n -values the defined determination ranges were documented as indices, see Figure 64, i.e. :

- r_{8-12} : linear regression between 8 and 12 % plastic (engineering) strain ε_{pl}
- $r_{2-20/(A_g-1)}$: linear regression between 2 and 20 % plastic (engineering) strain ε_{pl} or 2 % plastic (engineering) strain ε_{pl} and $(A_g - 1\%)$, if $(A_g - 1\%) < 20\%$ resp.

The values r_{8-12} is invalid, if $(A_g-1\%)$ is smaller than 12 %.

12. Discussion

12.1 General

- a) This review of published literature on tensile testing has covered the 100 years since the first published standards, and also contains significant episodes from even earlier times. It shows that the issues, which are problematic today, in the context of computer-controlled testing, have mostly been apparent in former times and were as hotly debated then in relation to the establishment of standards. In particular, it has always been clear to those practitioners with insight that tensile properties must not be viewed as inherent and absolute values for a given material and environment, but will depend critically on the form of the test piece, the testing machinery used and the procedures applied.
- b) It is apparent that many technological improvements, including computer control, have been made since the establishment of current standards, to the extent that much closer control can now be exerted on the mechanics of the test, if desired. Also, much more data can now be extracted from the test and in a more readily processable form. This makes it possible to define all relevant conditions and processes in a tensile test to a much higher degree than formerly. From the point of view of confidence in measured results and the establishment of level playing field for trade, it is highly desirable that rigorous standards be established to make use of this increased capability.

12.2 Specific Mechanical Issues

- a) **Strain Rate** - The published literature on tensile testing includes the results from many special studies and Round-Robin inter-comparison exercises. It is clear that, if the maximum strain rates permitted in the current standards are used (this may be desirable for reasons of production throughput) and the machine is not well-controlled, then falsely elevated yield strength results will be recorded, together with increased scatter.
- b) **Extensometry** - different technological methods for measuring and controlling strain and strain rate may be applied and several key papers in the literature show a consistent pattern in the effectiveness of these methods. Firstly, it is clear that extensometers mounted directly on the specimen provide better feedback control in a closed-loop system and less ambiguous measurement. However, it has not properly been recognised in standards that it is essential for the extensometer gauge length to span as much as possible of the testpiece parallel length as possible. If this is not done and significant plastic deformations take place *outside* the extensometer gauge length, control of strain may be lost and spurious results will be obtained.
- c) **Alignment and Gripping** - Off-axis loading, for whatever reason, is highly detrimental to accurate measurement. The effects are quantifiable if the misalignment is known, together with the specimen dimensions. They are

clearly worse in the case of thin specimens. Computer controlled machines are not able to compensate for such effects and it is of some concern that current standards offer no specific guidance. Alignment can be affected by the form of the specimen end-fixing. It has been reported that the following three common types of grip are recommended in descending order of preference, as a means of reducing the influence of bending on the tensile properties - (1) internally threaded grips used for cylindrical specimens with screw ends, (2) collet grips, used for button-ended specimens and (3) self-tightening wedge action grips, used with plain-ended specimens.

- d) **Testing machine frame compliance** - The literature shows that increased compliance in the testing machine frame or loading train is detrimental to accurate control and consistency of results, especially where extensometer feedback control cannot be properly implemented. This source of variation and error is not properly addressed in the current standard. In this context, hydraulic grips have been shown in various recent studies to be more effective than wedge action self-tightening grips, which are more compliant and may give less accurate alignment, depending on design.
- e) **Young's Modulus measurement** - Various studies show that the minimum standards specified for testing machines are inadequate for accurate measurement of Modulus and the standard tensile test is not the ideal method to determine this property. Reasonably accurate measurement is only practicable if the loading train and testpiece are very accurately aligned and a high-resolution pair (class 0.2) of averaging extensometers is employed.
- f) **Specimen Geometry and Ductility** - The influence of specimen geometry on the apparent ductility of test materials has been the subject of research for 150 years and some of the lessons from earlier work may have been overlooked in recent times. These issues have renewed importance for computer controlled testing standards as the technological basis of ductility measurement in a computer integrated situation may be somewhat veiled. Specimen geometry is often constrained by the available form of product and it is therefore not always practicable to specify ideal forms which will give more consistent and comparable results in terms of ductility. In addition, the results are shown in the literature to be strongly influenced by machine compliance and control factors. Hence, any standard should make clear to users, who place particular emphasis on ductility results, that these are even less to be considered as intrinsic material properties.

12.3 Impact of computer integration

- a) There is very little literature on the specific influence of computer integration in testing equipment and procedures. In the case of control functions, the main benefits have come through simplification of the setting up procedures and the avoidance of out-of-specification settings. Computer integrated machines are also able to process output data in real time and to implement accurate change of control decisions, provided these can be specified in advance. The potential for improved 'intelligence' and flexibility has also been noted by

recent authors. However, as with other applications of computers, vigilance is required to ensure that the machine is actually carrying out the task specified, as there is an increased tendency on the part of users to trust the software.

- b) The mechanics of data recording have always been a critical factor in tensile testing. In the era of analogue mechanical or electronic chart recorders, response to transients was recognised in the literature as an important factor. The new factor which enters the field with the advent of computer integration is that the capture rate for digital data acquisition systems needs to be specified carefully, to ensure that all relevant peaks and transients are indexed sufficiently well to ensure faithful curve-fitting.
- c) Automatic processing of data to provide key indices, such as 0.2% offset etc, without operator intervention, also requires accurate measurement of the initial elastic phase and, as noted in para 12.2 e) above, this is by no means an error-free task.
- d) In the context of standards, the greatest potential benefit from computer integration seems to lie in the greatly increased capability for high-speed data collection, processing and presentation. This enables better monitoring of the process, but current standards have not so far made use of this capability.
- e) The literature shows that industry has in the past been slow to phase out less technologically capable machines and this has to an extent put a brake on the development of standards which realise the full potential of up-to-date equipment. The advent of computer integration in this field, as in so many others, has tended to overcome this tendency and it is expected that the pressure to realise the benefits of technological compatibility and speed of processing will result in the removal of obsolescent equipment.

12.4 Quality issues

- a) There is evidence in the literature, as well as common experience, that many test houses are now accredited and subject to independent scrutiny of testing practice. Even with these controls it is clear from the literature that there may be divergence in results and it is therefore important to provide as many tools as possible to assist in the task of checking by result, rather than by process. In this respect, studies have shown that the use of Certified Tensile Reference Material, such as CRM 661, developed in the European context, can provide an invaluable norm.
- b) Reports reviewed highlight the importance of publishing uncertainty estimates of measured parameter, in addition to simple definitive results. As yet, the legal implications of such tolerances are not recognised however.
- c) Recent literature shows that there is a major loophole in the specification of procedures in current standards, whereby the limiting strain rates are specified, but no specification is made of the means through which these strain rates can be proved. Test houses can currently claim legitimately that their tests are carried out in accordance with national or international

standards and will provide the required load/displacement data. However, although the conditions may have been properly set, in the majority of cases, no proof is available that the testpiece deformation rate is at all times within the specified tolerances. Computer control offers the means to provide such proof and it should be a high priority in a new standard designed to reflect computer integration that such information should be made available routinely.

13.Conclusions

Although scientists have attempted to determine the characteristics of materials under an applied tensile load for over three hundred years, and it is now the centenary year of the publication of the first Tensile Testing Standard, there are still a number of technical issues that remain to be resolved if results determined at different laboratories throughout the world are to be regarded as being identical within the limits of measurement uncertainty. In particular, the advent and growth of computer controlled testing has added to number of technical issues that need to be addressed.

It is now generally recognised that results may only be directly compared provided the material is tested at similar strain-rates, which implies that the testing machine should ideally be operated under closed loop strain-rate control with the strain being measured directly on the testpiece parallel gauge length using an extensometer. If the machine can only operate in cross head control, then it is necessary to predetermine the cross head rate necessary to achieve the strain rate specified in the appropriate testing standard. Unfortunately, it is necessary to predetermine the testing speed for each combination of pull rods, grips and testpiece material since all these components affect the compliance of the test system and hence can influence the strain rate of the testpiece gauge-length.

This review has examined much of the published literature on the subject of tensile testing and the findings are summarised in the discussion under the following headings:

- Strain rate
- Extensometry
- Alignment and gripping
- Testing machine frame compliance
- Young's modulus measurement
- Specimen geometry and ductility
- Impact of computer integration
- Quality issues

The issues of testing speeds, data capture rates and software validation are now starting to be addressed in the latest versions of the International Standards which will help to improve confidence in the reliability of the reported results. However, it should be noted that some issues, such as the influence of alignment, the use of side-to-side averaging extensometry, and machining and

surface finish of the testpiece may still not be adequately specified in the Standards.

Nevertheless, in general the material properties determined during tensile testing are now much better understood and are widely used with confidence in the design of safety critical components or for product release certification testing.

14. Acknowledgements

Staff of the University of Strathclyde and at National Physical Laboratory are acknowledged for editorial assistance during the preparation of this review.

15. References

15.1 STANDARDS

- ASTM E8-24T (1924) *Standard Test Methods for Tension Testing of Metallic Materials*
- BESA Report No3 (1903) '*Report on the Influence of Gauge Length and Section of Test Bar on the Percentage Elongation*' by Prof. W.C. Unwin, Pub BESA / BSI London.
- BS18 (1904) '*Forms of Standard Tensile Test Pieces*' Pub: Engineering Standards Committee, London.
- BS18 (1907) '*Forms of Standard Tensile Test Pieces*' Pub: Engineering Standards Committee, London.
- BS18 (1910) '*Forms of British Standard Tensile Test Pieces*' Pub: British Standards Institution, London.
- BS18 (1938) '*Tensile Testing of Metals*' Pub: British Standards Institution, London.
- BS18 (1950) '*Tensile Testing of Metals*' Pub: British Standards Institution, London
- BS4759: (1971) [*withdrawn*] 'Method for the determination of k-values of a tensile testing system
- DIN 1605 (1924) '*Werkstoffprüfung: Versuche*'
- DIN –DVM125 (1940) '*Probestäbe für Zugversuche*'
- ISO 6892 (1998) '*Metallic Materials – Tensile tests at Ambient Temperatures*'
- ISO 10 275; 1993-02, Metallic materials – Sheet and Strip – Determination of tensile strain hardening exponent, International Organisation for Standardization, Genève 20
- ISO 10 113; 1991-05, Metallic materials – Sheet and Strip – Determination of plastic strain ratio, International Organisation for Standardization, Genève 20
- Stahl-Eisen-Prüfblatt 1125; 1984-11, Ermittlung des Verfestigungsexponenten (n-Wert) von Feinblech im Zugversuch, 1. Ausgabe, Verlag Stahleisen mbH, Düsseldorf (1984)

- Stahl-Eisen-Prüfblatt 1126; 1984-11, Ermittlung der senkrechten Anisotropie (r-Wert) von Feinblech im Zugversuch, 1. Ausgabe, Verlag Stahleisen mbH, Düsseldorf (1984)

15.2 PAPERS & BOOKS

Aegerter J (1993), "Optimierung der Bestimmung des Verfestigungsexponenten und der senkrechten Anisotropie (n- und r-Wert) beim rechnergesteuerten Zugversuch", Internal Memorandum, VAW aluminium AG, 1993-06

Aegerter J., Bloching H.,(2002) "Tensile Test on Materials according to EN 10002-1 (issue December 2001)", 11th trade fair for testing technology (Zwick Hausmesse Oct. 2002), Page 167 - 188

Aegerter J., Bloching H.,(2003) "Probenformen- und Herstellung für die Prüfung metallischer Werkstoffe - Schwerpunkt Zugversuch (Specimen Geometries and Specimen Preparation for Testing Metallic Materials - Especially Tensile Test)", 12th trade fair for testing technology (Zwick Hausmesse Oct. 2003), Page 50 - 62

Aegerter J, Bloching, H, and Sonne, H-M, (2001) 'Influence of the testing speed on the Yield / Proof Strength in compliance with EN 10002 –1.' MP Materialprüfung. 43 (10) 393 – 403.

Aegerter J., Keller S., Wieser D.: (2003) "Prüfvorschrift zur Durchführung und Auswertung des Zugversuches für Al-Werkstoffe", Conference transcript of the conference "Werkstoffprüfung 2003", Verlag Stahleisen GmbH, Düsseldorf, Page 139 – 150 *English translation: 'Test Procedure for the Accomplishment and Evaluation of the Tensile Test for Aluminium and Aluminium Alloys' : (2004)*

ASTM Report (1994) Research Report RR E-28 1004 Round Robin Results of Interlaboratory Tensile Tests.

Barr, A. (1905) J West of Scotland Iron and Steel Institute, v17 no.4.

Bauschinger, J (1881) Zivilingur, Vol 27. p 289-347

Bell, Stephanie. (1999) 'A beginners guide to uncertainty of measurement', NPL Good Practice Guide No. 11. ISSN 1386-6550.

Birch, K. (2001) 'Estimating Uncertainties in Testing'-Measurement Good Practice Guide No 36, Pub: British measurement & Testing Association / National Physical Laboratory, Teddington, TW110LW, UK. ISBN1368-6550.

Bressers, J. (1995) ' A code of Practice for Measurement of Misalignment Induced Bending in Uniaxially Loaded Tension – Compression test pieces' Report EVR 16138 EN, European Commission, Petten. ISBN 92-826-9681-2

Dean G.D, Loveday M.S. , Cooper, P.M. , Read, B.E. , Roebuck, B. and Morrell, R. (1995) 'Aspects of Modulus measurement' Chap8. pp 150- 209 in 'Materials Metrology and Standards for Structural Performance' Ed B.F.Dyson, M.S.Loveday & M.G.Gee. Pub Chapman & Hall, London.

Fairbairn, W (1842) 'An experimental enquiry into the strength and other properties of cast iron from various parts of the United Kingdom' Mem. Manchester Lit. Phil. Soc. Vol. 6, 172-273.

Fairbairn, W (1856) 'On the tensile strength of wrought iron at various temperatures' Brit.

Assn. Annual Rep. 405-422

Fischer and Haibach (1987) 'Checking and Improvement of the Alignment of Flat Specimen Gripping Devices', ASTM STP 1025 pp136-159, ASTM Philadelphia ISBN 0-8031-1251-3

Galilei, G (1638) '*Discorsi e Dimostrazioni matematiche*' published in Leiden.

Gray, T.G.F & McCombe, A (1992) '*Influence of specimen dimension and grip in tensile testing steel to EN 10 002.*' J. Iron & Steel Making vol. 19, No 5, 402 – 408

Gray, T.G.F & McCombe, A (1992) *Research on Specimen Geometry Effect in Tensile Testing*, Report on Project MTD – SX9/15 to BSI and DTI, University of Strathclyde

Gray, T.G.F. (1988) '*Tensile Testing*'. Chapt.1, 1-42, in '*Mechanical Testing*' Ed. Curbishley. Book 445. Pub Inst. of Metals, London

Gray, T.G.F. and Sharp, J. (1987), *Influence of Machine Type and Strain Rate Interaction in Tension Testing in Factors that affect the Precision of Mechanical Tests*, Ed: Papirno & Weiss, ASTM STP 1025, ISBN 0-8031-1251-3

Grumbach, M., Roesch, L., (1977), Doc. Sidér. Cir. Inf. Tech., v 34, (7/8), pp 1693-1700

Helms, R., (1975), Bänder Bleche Rohre, v16, (6) pp 241-244

Hinton, C.E., (1995), 'Dynamic Control Methods', in Materials Metrology and Standards for Structures Performance, Ed: B.F. Dyson, M.S. Loveday and M.G. Gee, pp 34-54, Chapman & Hall, London, ISBN 0412 582 708.

Hsu, T.C., Littlejohn, G.S., Marchbank, B.M., (1965) Proc ASTM, v 65, pp 874-898.

Ingelbrecht, C & Loveday, M.S. (2000) '*The Certification of Ambient Temperature Tensile Properties of a Reference Material for Tensile Testing According to EN 10002-1.*' EU Report 19589 EN.

ISO Bulletin (1987) '*ELOT Prize goes to ISO*' ISO Bulletin, 10-11, April 1987

Johnson, R.F., (1967), in Proc. Conf BISRA/ISI, Scarborough paper MG/Conf/67.

Johnson, R.F. and Murray, J.D., (1966), in Proc. BISRA/ISI Conf, Eastbourne.

Kandil, F.A. (1998) '*Measurement of bending in uniaxial fatigue testing*' Measurement Good practice Guide No. 1, National Physical Laboratory, ISSN 1368-6550, March 1998

Kandil, F.A., Lord, J.D., Bullough, C.K., Georgsson, P., Legendre, L., Money, G., Mulligan, E., Fry, A.T., Gorley, T.A.E. & Lawrence, K.M. (2000) '*The UNCERT Manual of Codes of Practice for the Determination of Uncertainties in Mechanical Tests on Metallic Materials*' [CD-ROM, - available from NPL] ISBN 0-0946754-41-1

Kennedy, A.W.B., Ewing, J.A., Capper, D.S., Beare, T.H. & Unwin, W.C. (1896), '*Calibration of Instruments used in Engineering Laboratories*' Report of the British

Association, pp 538-548.

Kennedy, A.W.B., Ewing, J.A., Capper, D.S., Beare, T.H. & Unwin, W.C. (1895), '*Calibration of Instruments used in Engineering Laboratories*' Report of the British Association, pp 497-500.

Kennedy, A.W.B., Ewing, J.A., Capper, D.S., Beare, T.H. & Unwin, W.C. (1897), '*Calibration of Instruments used in Engineering Laboratories*' Report of the British Association, pp 424-426.

Krisch, A. and Lakshmanan, R., (1970), Der Einfluss von Geschwindigkeit und Prüfmaschine auf Streckgrenze und Zugfestigkeit von Stahl, Forsch. des Landes N-W no. 2069, Koln, Westdeutscher Verlag.

Lange, G. (1972) '*Influence of the hardness of the testing machine on the results of the tensile test*', Archiv Eisenhüttenwes, v 43, (1) pp 67-75

Lord, J.D. (2002) '*Review of Methods and Analysis Software for the Determination of Modulus from Tensile Tests.*' NPL Measurement Note MATC(MN) 41. Pub: National Physical Laboratory, London, UK

Lord, J.D. and Orkney, L.P. (2000) '*Elevated Temperature Modulus Measurements using the Impulse Excitation Technique (IET)*' NPL Measurement Note CMMT(MN) 049. Pub: National Physical Laboratory, London, UK

Lord, J.D. & Roebuck B (1997) '*Recommended Methods for the Determining Young's Modulus from Tensile Tests.*' NPL Measurement Note CMMT(MN) 16. Pub: National Physical Laboratory, London, UK

Loveday, M.S. (1982) '*High Temperature and Time Dependent Mechanical Testing: an Historical Introduction.*' Chapter 1, pp1-12. 'Measurement of high temperature mechanical properties of materials', Ed: M.S. Loveday, M.F. Day & B.F. Dyson. Pub. HMSO, London.

Loveday, M.S. (1992) '*Towards a tensile reference material*', Chapter 7, 111-153 in '*Harmonisation of Testing Practice for High Temperature Materials*', Ed M S Loveday and T B Gibbons. Pub. Kluwer (formerly published by Elsevier Applied Science).

Loveday, M.S. (1999) '*Room Temperature Tensile Testing: A Method for Estimating Uncertainty of Measurement*' CMMT (MN) 048 Pub: National Physical Laboratory, UK.

Loveday, M.S. (1996), "*Creep Testing: Reference Materials and Uncertainty of Measurement*". pp 277-293 in '*The Donald McLean Symposium - Structural Materials: Engineering Applications Through Scientific Insight.*' Ed. E D Hondros & M McLean. Pub: Inst. of Materials, London.

Markowski, W.: (1991) '*Machine and method for uniaxial mechanical material testing*'; US-Patent No. 5,005,424, April 9, 1991.

Mathew, M.D., Marman, S.L., Rodriguez, P., (1985), J Testing and Evaluation, v 13, (3), pp 191-195.

McCarthy, P.R. (2003) '*Development of Testing Standards*', Chap. 8, 153-162, in '*Mechanical Testing Equipment 1850 to 2000: Design Principles and Control Methods*',

Diploma Imperial College –Thesis.

McEnteggart, I, & Lohr, R.D. (1995) 'Mechanical Testing Machine Criteria' Chap 2, pp 19-33 in *Materials Metrology and Standards for Structural Performance*, Ed: BF Dyson, MS Loveday and M. G. Gee, Chapman & Hall, London, ISBN 0412 582708.

Misiolek, Z., (1964) *Revue de Métallurgie*, v 61, pp 999-1108

Morley ,A (1940) '*Strength of Materials*' Pub: Longman & Green, London.

Morrison, J.L.M., (1934), *The Engineer*, v 158, pp 183-185

Oliver, D.A., (1928) *Proc I MechE*, v2, pp 827-864

Poner, D.M., Freidenzon, Yu. E., et al, (1975), *Industrial Laboratory*, v 41, (6), pp 914-915

Pretnar, B., Yebuah, R.A.W., (1987), *Materialprüfung*, v 29, (4), pp 104-106

Rennie jun. G. (1818) '*Accounts of experiments made on the strength of materials*' *Phil Trans Roy Soc MDCCCXVIII* 118-136.

Roche R and Loveday M S. (1992). "*Harmonisation and Improvements in Eurostandards*". Chap. 3., 33-52, in *Harmonisation of Testing Practice for High Temperature Materials*. Ed. M S Loveday and T B Gibbons. Pub. Elsevier Applied Science.

Roebuck, B. , Lord. J,D., Cooper, P.M. and McCartney L.N. (1992) 'Data Acquisition and Analysis of Tensile Properties for Metal Matrix Composites' ASTM Workshop on accuracy of Load & Strain Measurements, Miami, Nov 18th 1992, *ASTM J. Testing & Evaluation, JTEVA*, 22(1) pp 63-69, 1994.

Roesch, L., Coue, N., Vitall, J. and Fant, M Di. (1993) '*Results of an Interlaboratory Test Programme on Room Temperature Tensile Properties*' IRSID Report NDT 93310.

Ruske,W. , Becker, G.W. & Czichos,H (2003) '*125 Jahre. Forschung und Entwicklung Prüfung, Analyse, Zulassung Beratung und Information in Chemie – und Materialtechnik*'. Pub: BAM, Berlin.

Sato, S. (1973), *J Japan Inst Light Metals*, v 23, (8), pp 368-375

Siebel, E (1958) '*Handbuch der Werkstoffprüfung*'. Pub: Springer-Verlag

Skilton, P.J. (1990) '*Kirkaldy Testing Museum Booklet*'

Smith, A.I. (1963) '*William Fairbairn and Mechanical Properties of Materials*' *The Engineer* 4th October.

Smith, D (1982) '*David Kirkaldy (1820 – 1897) and Engineering Materials Testing*' *Newcomen Society - Eng & Tech Trans*, Vol 52, 49 – 65.

Sonne, H-M, Robiller, G., Akpolat, H., (1983), *Stahl und Eisen*, v 103, (7), pp 331-336

TENSTAND (2004) WP4 Results & Analysis of Tensile Test Inter-laboratory Exercise: H Klingelhöffer S Ledworuski & S. Brookes BAM Technical report ? EU Funded Project 'TENSTAND' , Contract Number G6RD-2000-00412.

(Also reported in '*Tensile Testing of Metallic Materials: A Review.*' By M.S.Loveday, T.Gray & J. Aegerter, see NPL web site.

[Further information about the project may be found on the following web site : <https://www.npl.co.uk/products-services/advanced-materials/Tensile-testing>

Timoshenko, S.P. (1953) '*History of Strength of Materials*', Pub: McGraw-Hill, New York. (Reprinted 1983, Pub: Dover publications Inc. New York)

Todhunter, I & Pearson, K (1886), '*A History of the Theory of Elasticity and the Strength of Materials from Galilei to the Present Time*' Vol. 1, 1-6. pub Cambridge University Press.

Tomenko, Yu.S., Khristenko, I.N., Feld'man, E.I., (1979) Industrial Laboratory (USSR), v 45, (4), pp 461-468

Unwin, W.C. (1910) '*The Testing of Materials of Construction.*' 3rd Edition Longmans, Green & Co, London (Modulus data pp236-237)

Varoufakis G.J., (1987) '*Materials Testing in Classical Greece, Technical Specifications of the 4th Century BC*' by Pub: Hellenic Organisation for Standardization,

Varma R.K. and Loveday M.S.(2002) ,*The Validation of the Draft Standard for Instrumented Impact Testing (IIT) of Metallic Materials Version 10:1994*'

Proceeding of Charpy Centenary Conference-CCC 2001, Poitier, France. 2nd –5th October 2001, published in '*From Charpy to Present*

Impact Testing' pp181 – 188, Ed D.Francois & A. Pineau , ESIS Publication No 30, Pub: Elsevier

Vasin, I.L., (1975) Industrial Laboratory, v 41, (10) pp 1561-1563

Woodward,C. D. (1972) '*BSI:the story of Standards*' Pub: British Standards Institution, London.

Tables

Name	Year	Percentage Elongation
Barba	1880	Proportional to $\sqrt{A_o}l_g$
Unwin	1903	$= 100 (a + b \sqrt{A_o}/l_o)$
Bertella	1922	$= \mu(\sqrt{A_o}/l_o)^\alpha$
Oliver	1928	$= \mu(\sqrt{A_o}/l_o)^\alpha$

A_o Original Area
 l_g, l_o Gauge Length
 μ, α Constants

Examples of Formula Relating Elongation to Specimen Dimensions

Table 1

(Hsu et al (1965))

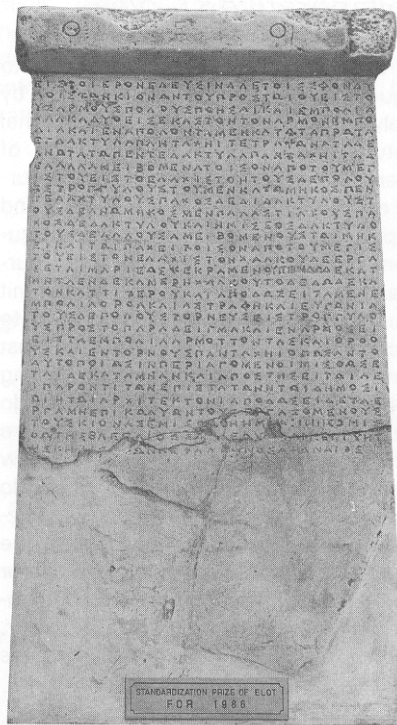
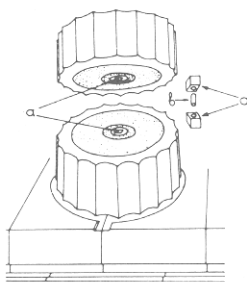


Figure 1 - 4th Century BC Stele of Eleusis. (ISO Bulletin, 1987)



▲ The use of empolia illustrated in Materials testing in Classical Greece

Diagram of the Temple of Aphaia displays a number of technical construction features including ties and empolia

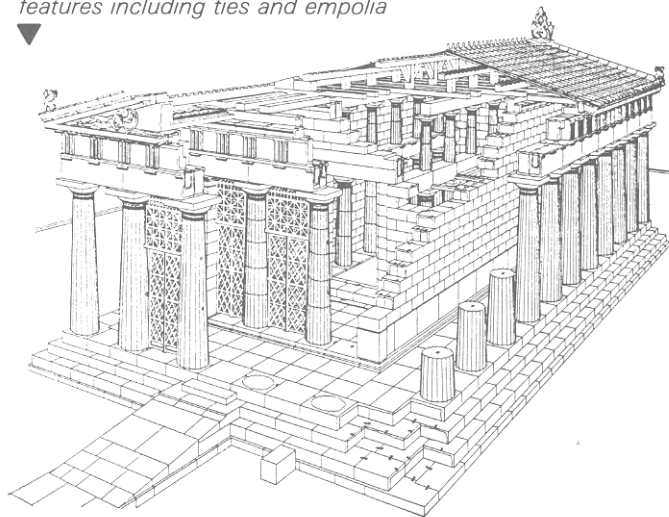
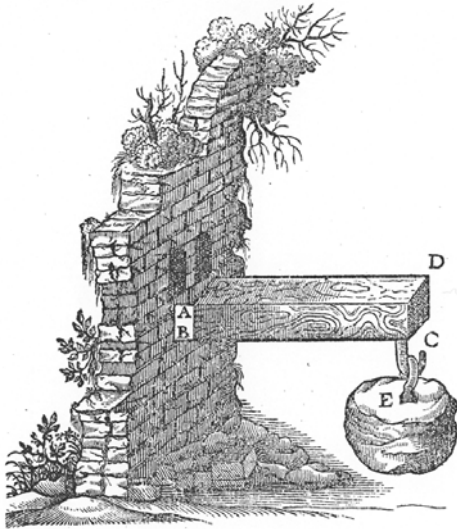


Figure 1 - Use of Bronze spigots (poloi) for keying together components of Greek stone columns (Varoufakis, 1987)



(From the *Discorsi*, Leiden 1638.)

Figure 2 - Galileo's bending theory

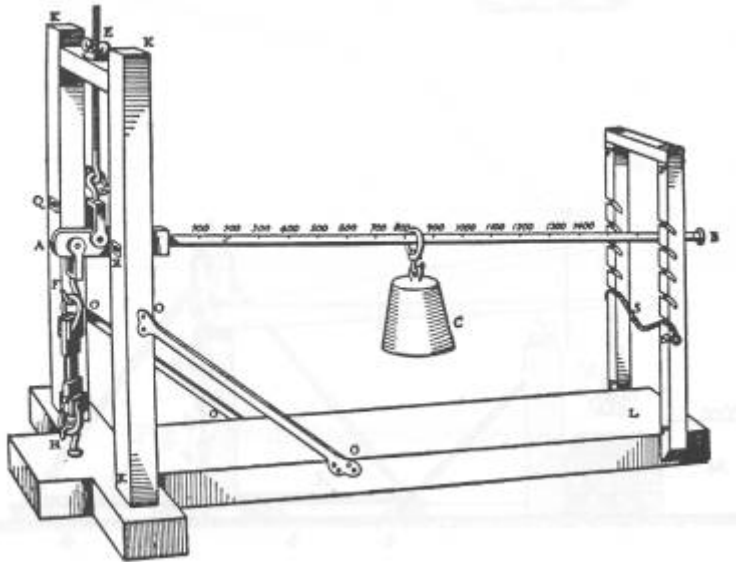


Figure 3 - Petrus van Musschenbroek lever testing machine

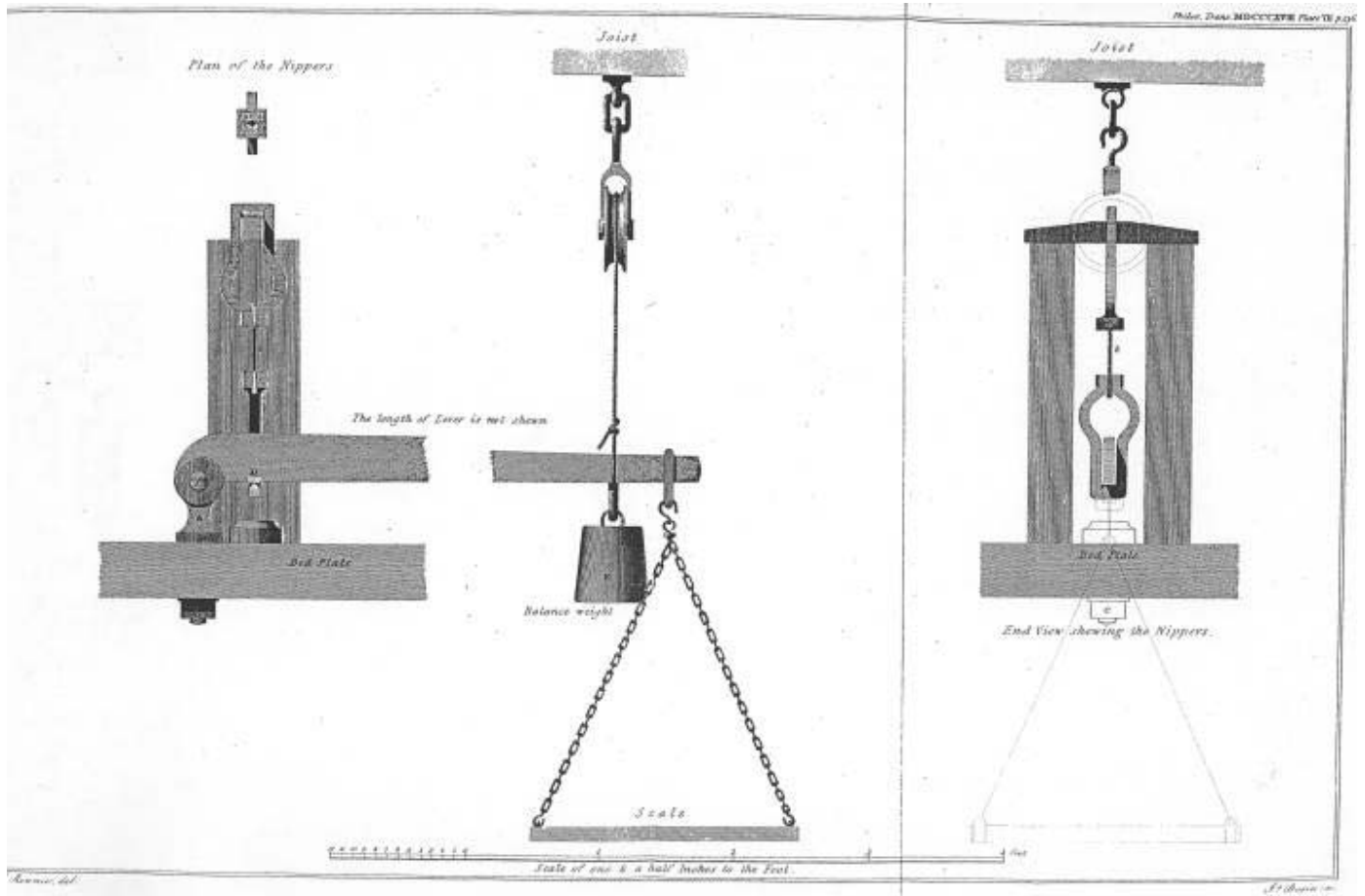


Figure 4 - George Rennie's lever tensile testing machine. (Rennie, (1818))

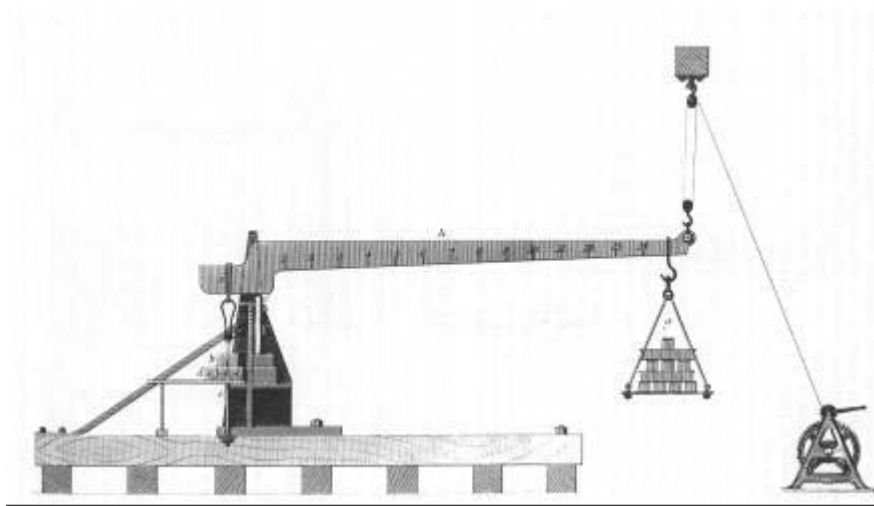


Figure 5 - Fairbairn's tensile testing machine used for high temperature tensile testing

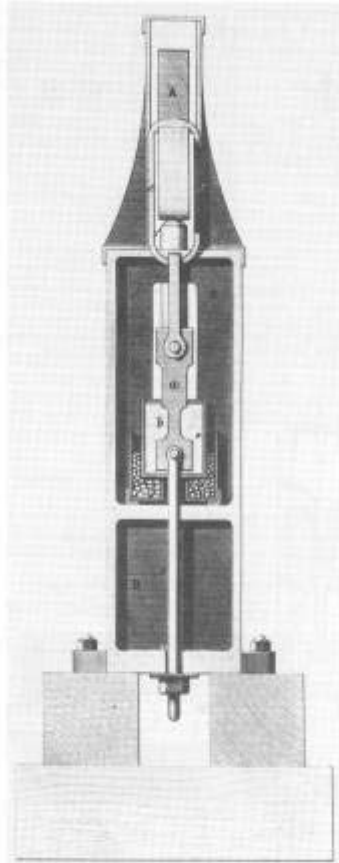


Figure 6 - Fairbairn's tensile testing machine used for high temperature tensile testing

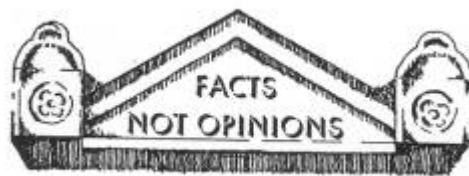
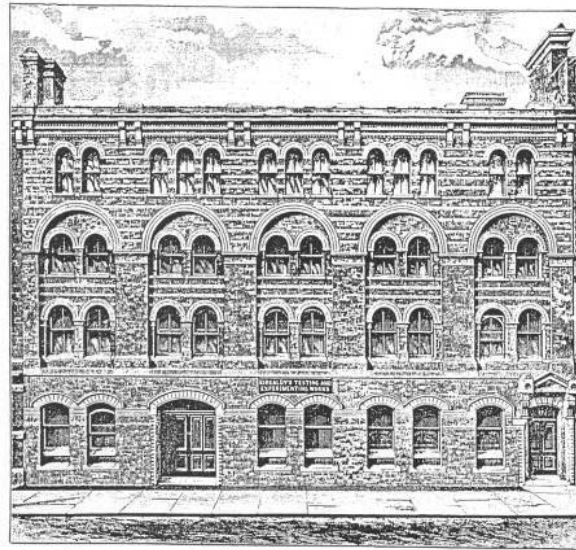


Figure 7 - Kirkaldy's motto inscribed over the doorway of his testing works. (Skilton, (1990)



DAVID KIRKALDY & SON,
TESTING + AND + EXPERIMENTING + WORKS,
99 SOUTHWARK STREET,
LONDON.

Figure 8 - - Etching of Kirkaldy's Testing Works in Southwark, note the pediment over the door on the bottom right hand side, which is inscribed with the motto shown in Figure 7

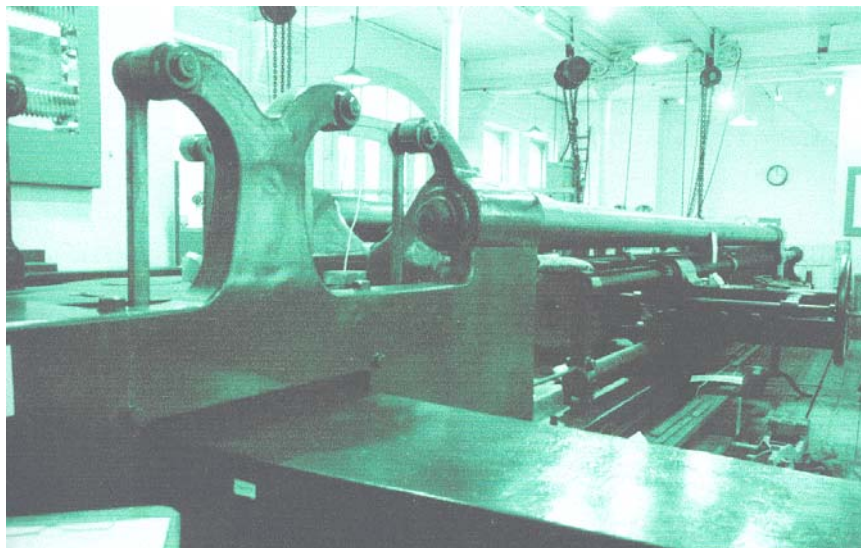


Figure 9 Kirkaldy's 300 ton horizontal hydraulic testing machine as seen today in Southwark, London.

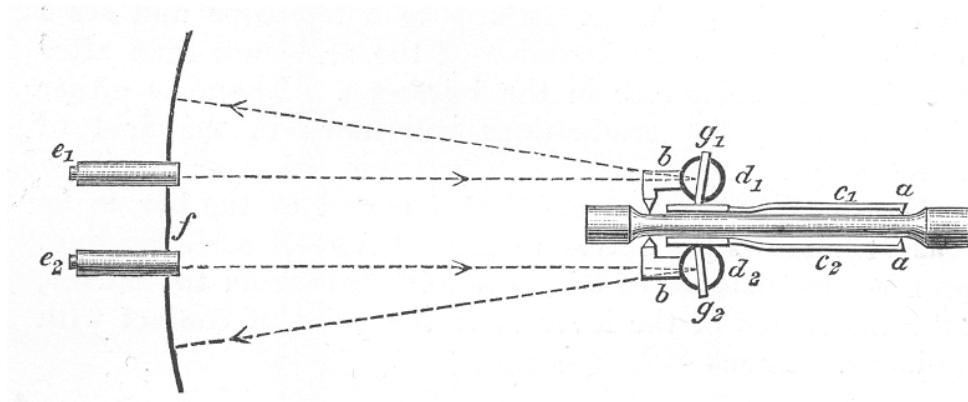


Figure 10 - - Bauschinger's Roller and Mirror Extensometer (Unwin (1910))

Key: a & b – knife edges contacting the testpiece; c- limbs translating the movement of knife edges 'a' to the rollers; d- ebonite rollers on accurately centered spindles; e – telescope-eyepieces focused on scale via mirrors; f- scale at a distance of ~ 4m; g- mirrors connected to the rollers

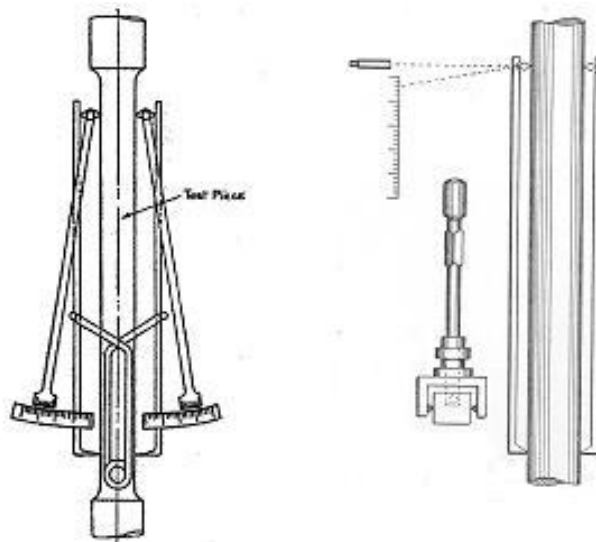


Figure 11. Diagrams of Martens extensometers. a) (left) lever type, b) (right) mirror and rhomb type (Note: insert on the R-H diagram shows the rhomb with its counterbalance and spindle which supports the mirror.)

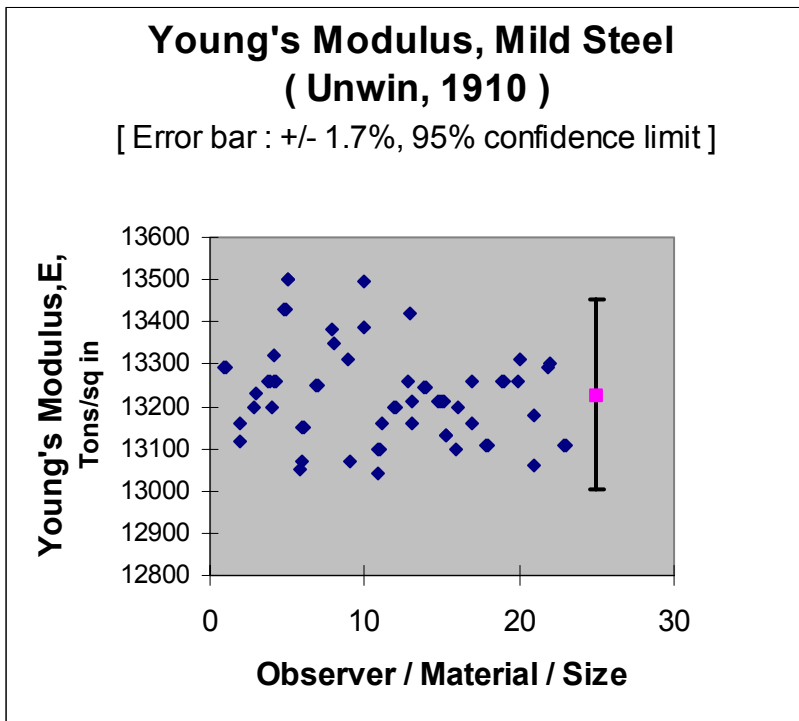
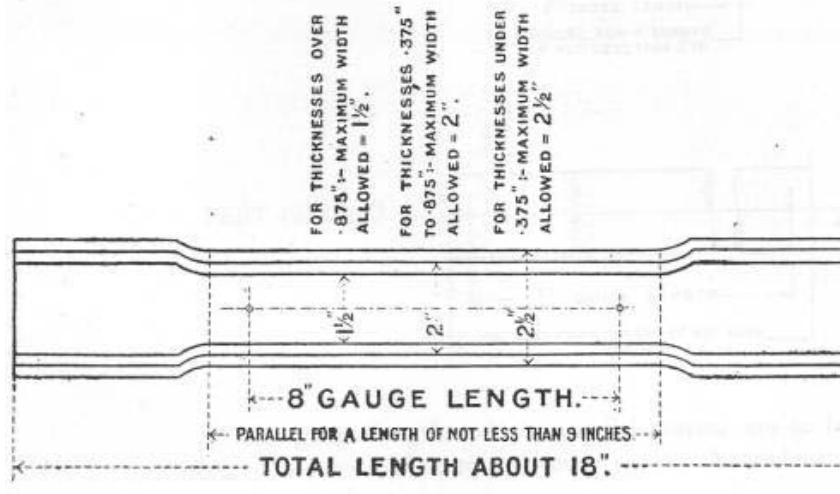


Figure 12 Values of Young's modulus reported by Kennedy et al (1895),(1896),(1897)) and summarised by Unwin (1910)

TEST PIECE A.

FOR PLATES AND OTHER STRUCTURAL MATERIAL.



NOTE:—It will be observed that the widths given above, being maxima, do not exclude the use of the usual 1 1/2 in. x 8 in. test piece.

TEST PIECE B.

FOR BARS, RODS, AND STAYS.

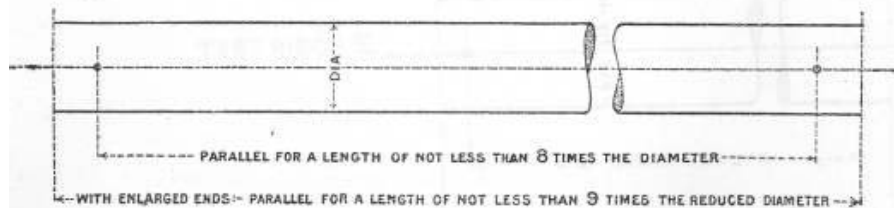
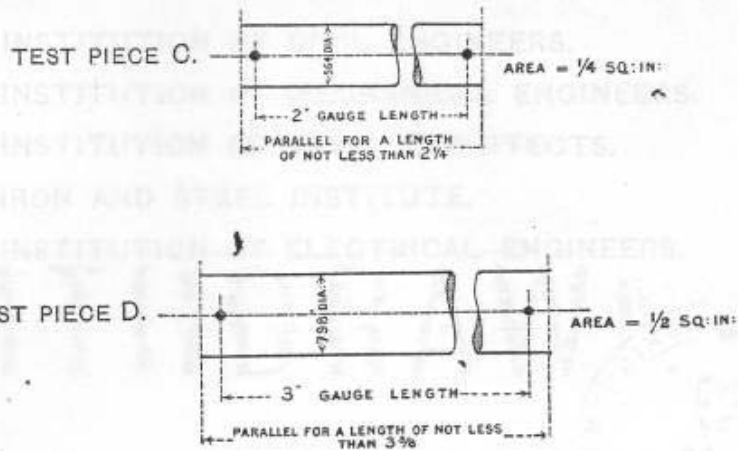


Figure 13 - Extract from BS 18 'Forms of Standard Tensile Test Pieces', 1904

TEST PIECES C AND D. FOR TYRES, AXLES, FORGINGS, CASTINGS, ETC.



The gauge length and the parallel portion are to be as shown. The form of the ends is left open in order to suit the various methods employed for gripping the test piece.

TEST PIECE E.

The following test piece may be used when a test piece is required similar in form to C and D, but of larger dimensions.

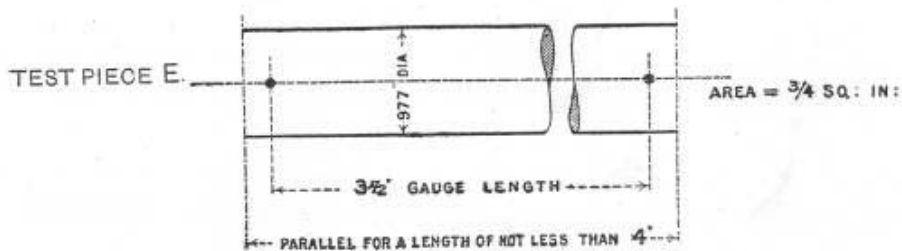


Figure 14 - Extract from BS 18 'Forms of Standard Tensile Test Pieces', 1904

Room temperature tensile testing: EN 10002 Part 1

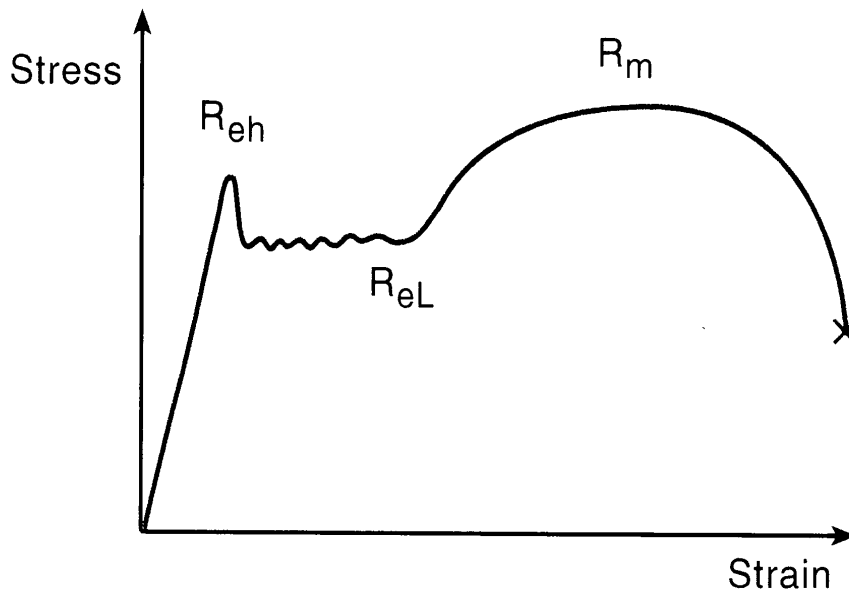


Figure 15 Schematic diagram of tensile stress-strain curve for material exhibiting upper & lower yield characteristics

Room temperature tensile testing: EN 10002 Part 1

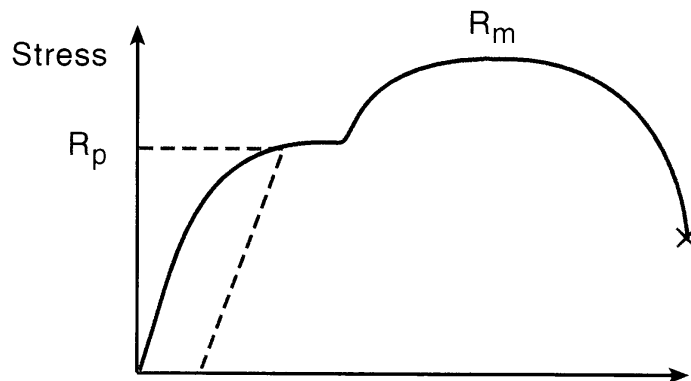


Figure 16
Schematic diagram of a tensile stress-strain curve, for material exhibiting proof stress characteristics.

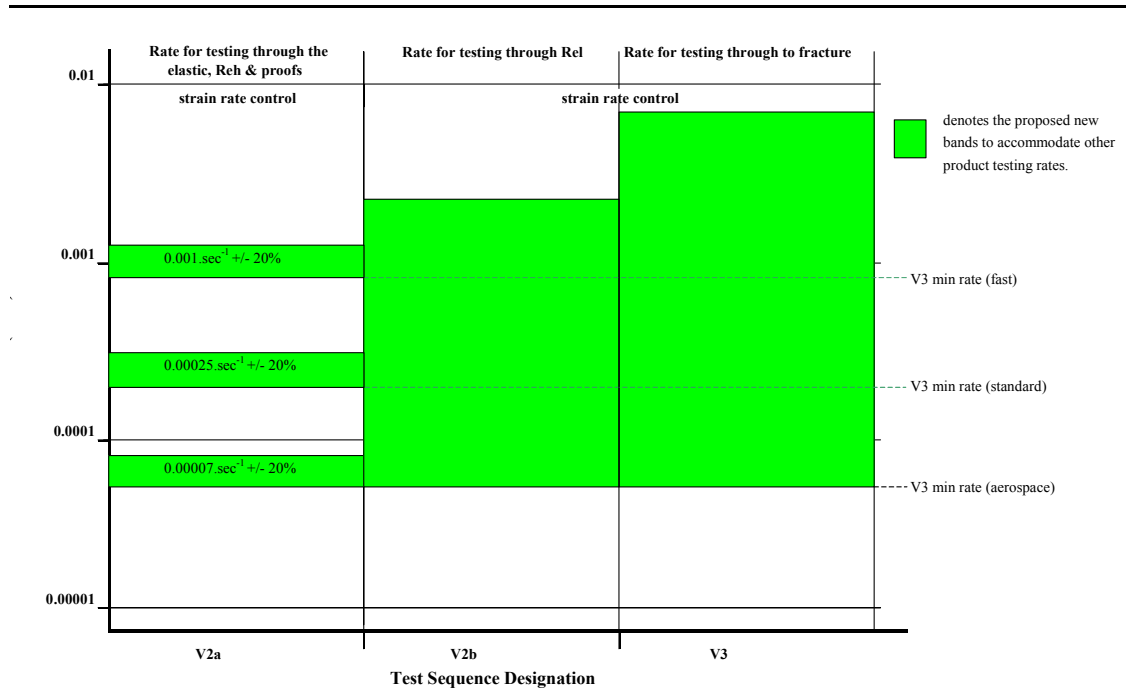


Figure 16 Proposed new testing speeds considered at ECISS TC1 WG1 September 2003 (Diagram courtesy of Stuart Sotheran, CORUS UK)

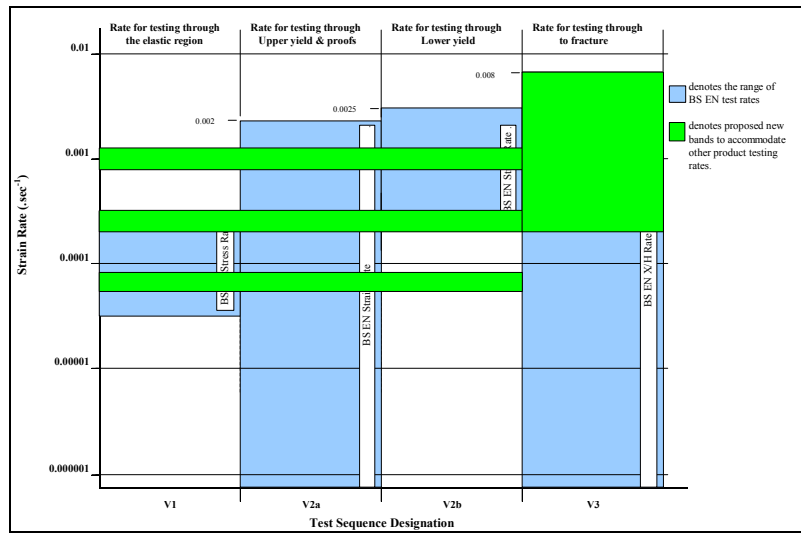


Figure 17 Testing speeds as in Existing EN10002 Part1 (blue) and those in N40E February 2003 . (Diagram courtesy of Stuart Sotheran, CORUS UK)

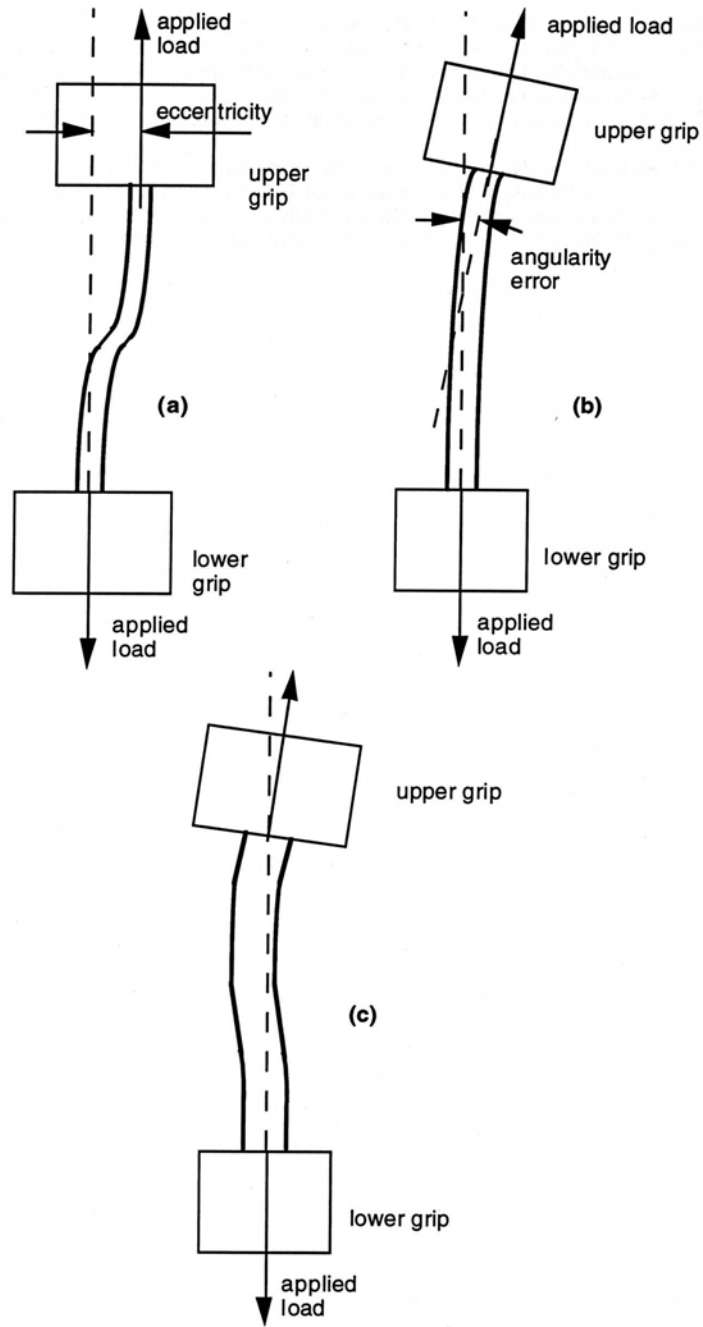


Figure 18 1 Sources of alignment error due to grip system

Figure 18 Sources of alignment error due to grip system

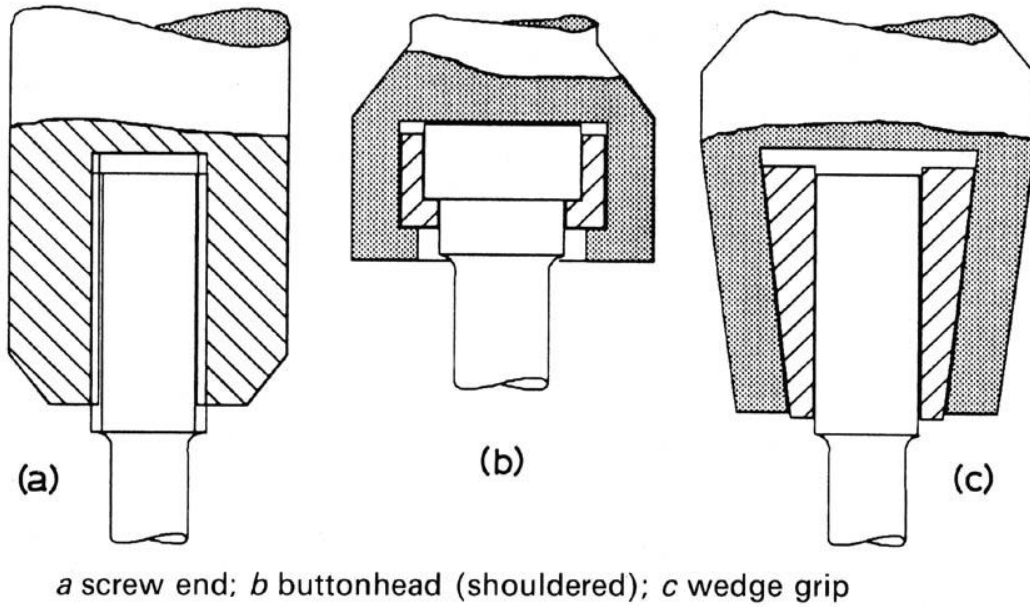


Figure 19. Types of grip.

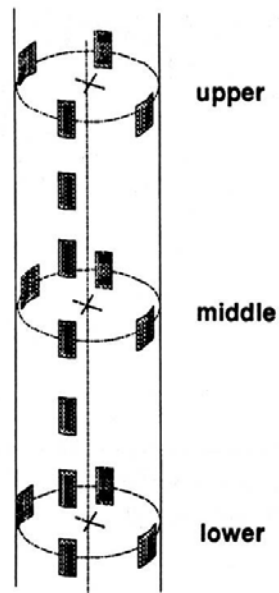


Figure 20 Strain gauge layout

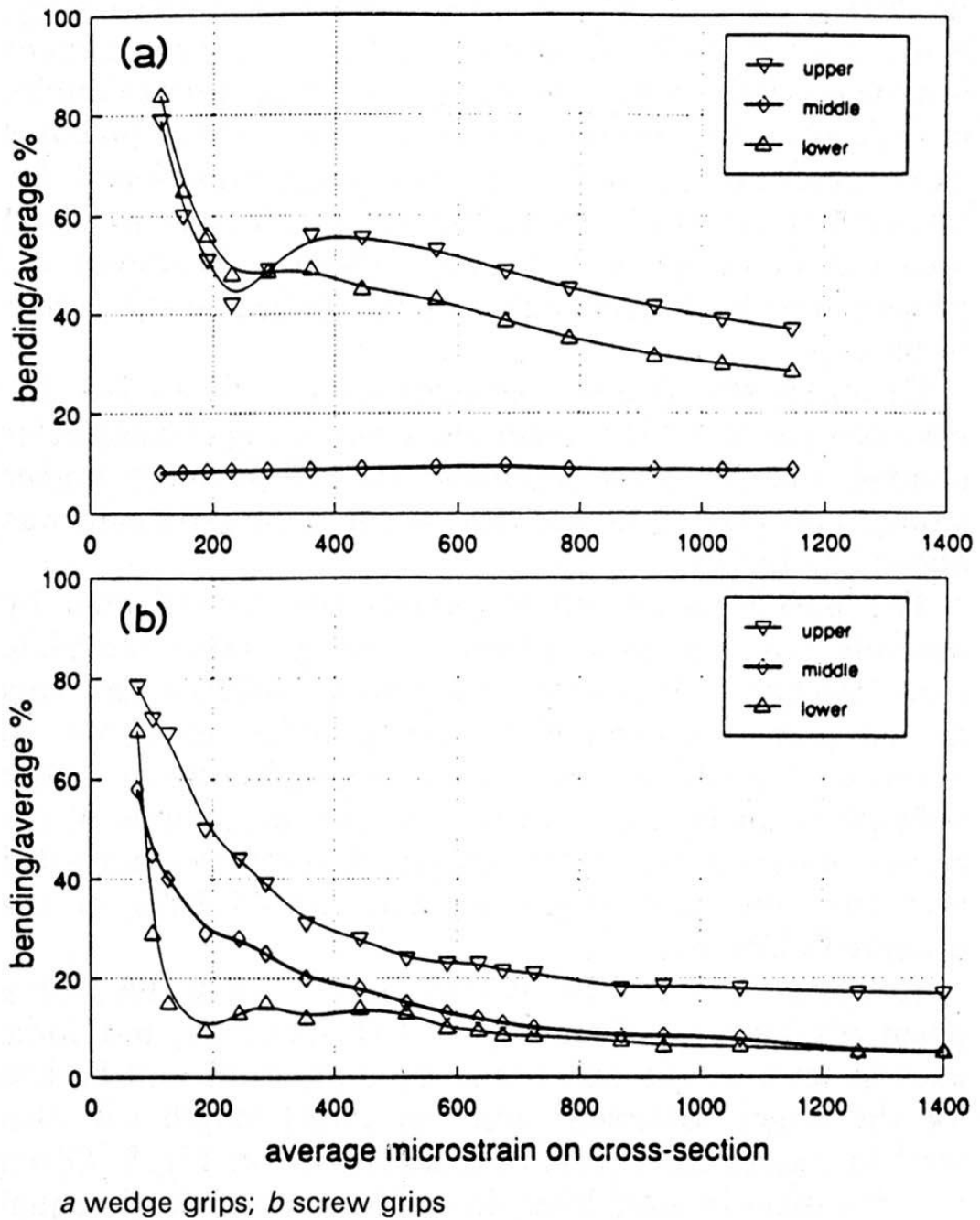


Figure 21 - Strain gauge tests results showing percentage bending in elastic region [Gray & McCombe, 1992]

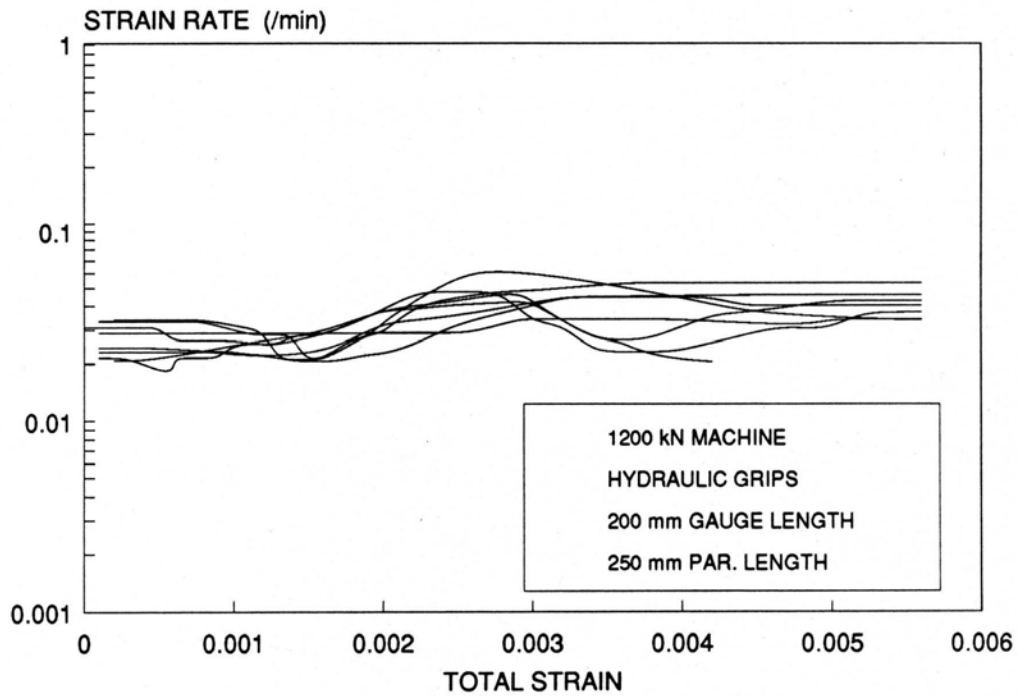


Figure 22 - Variation of strain rate in 20mm wide specimens – 40mm thick plate

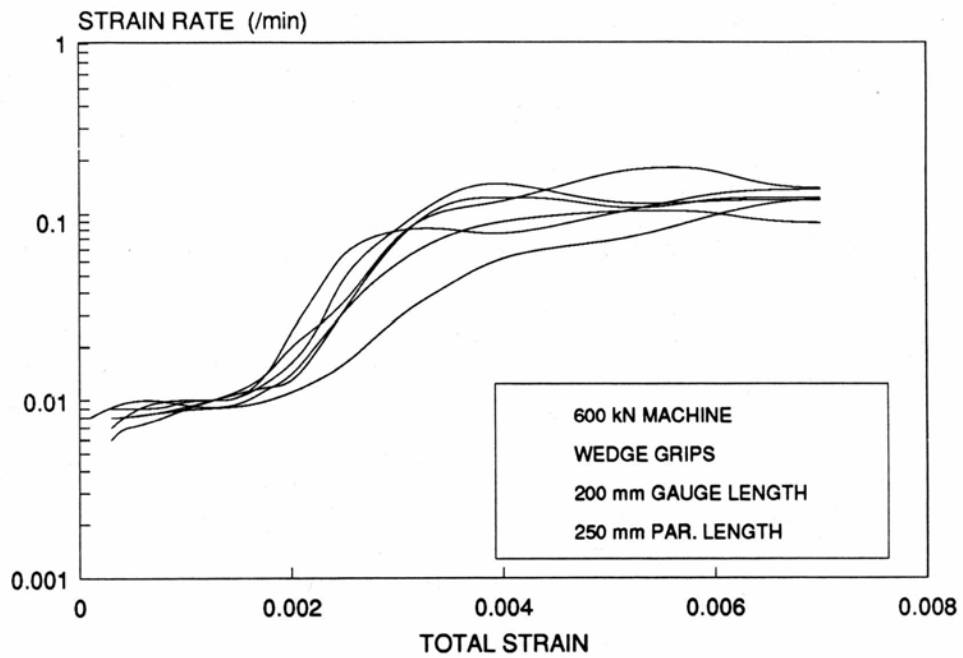


Figure 23 - Variation of strain rate in 20 m wide specimens in 40 mm thick plate

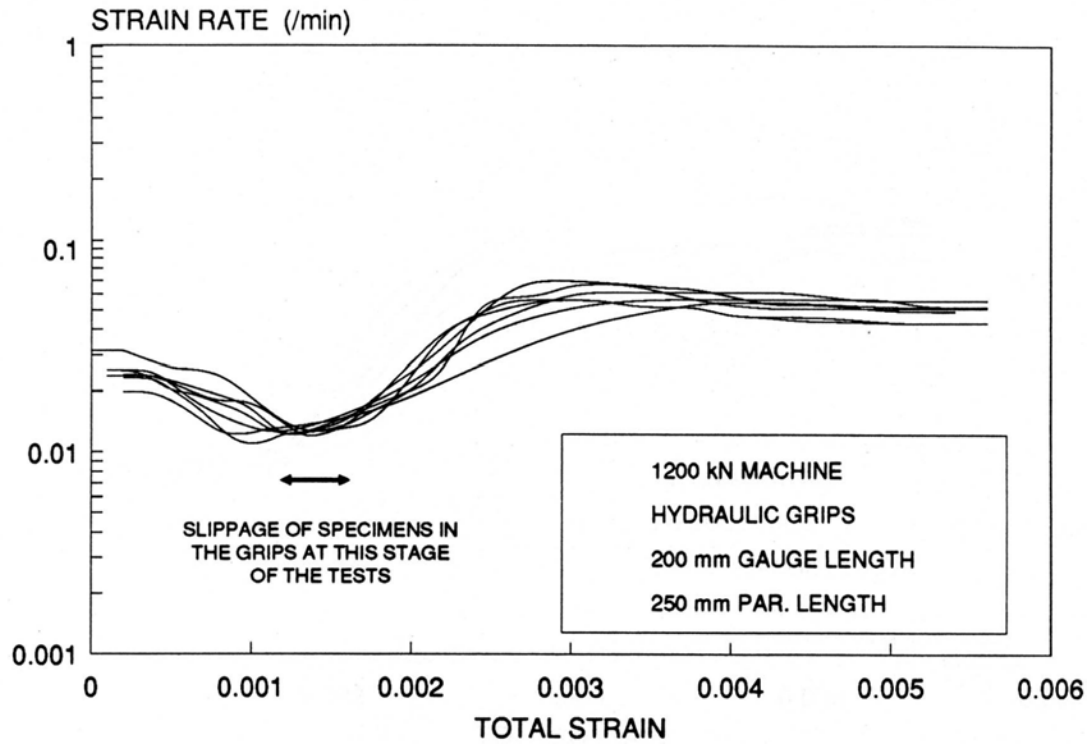


Figure 24 - Variation of strain rate in 40 m wide specimens in 40 mm thick plate

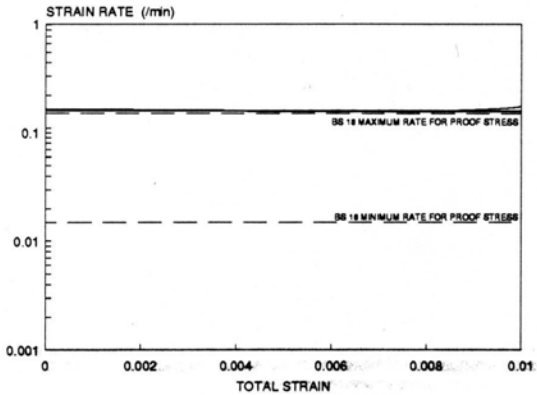


FIG 1a BRASS BAR - CLH2 - PLAIN ENDS

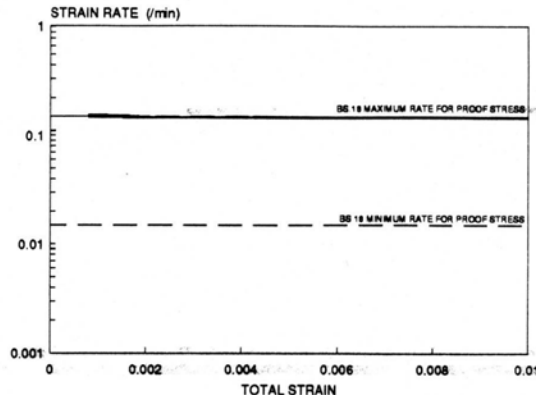


FIG 1b BRASS BAR - CLH2 - SCREW ENDS

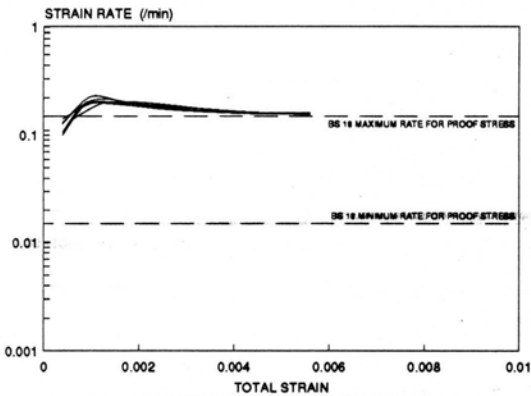


FIG 1c COPPER WIRE - CLHM - WEDGE GRIPS

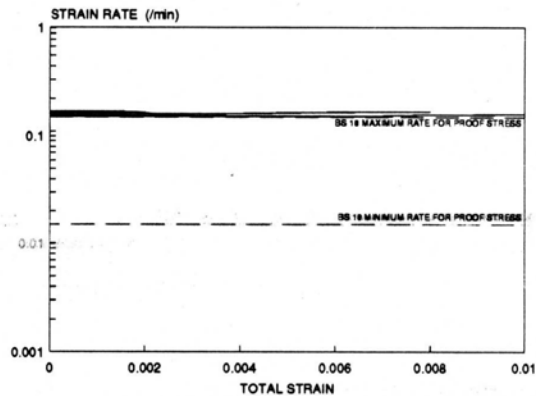


FIG 1d INCONEL BAR - CLH2 - SCREW ENDS

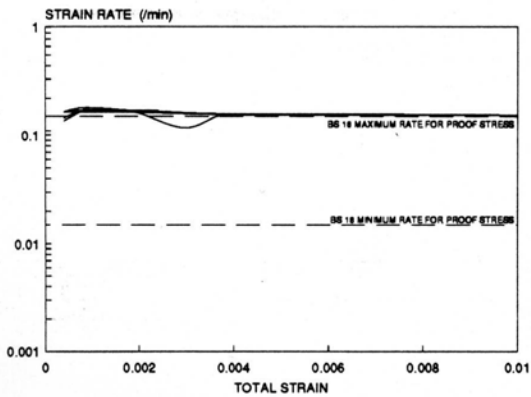


FIG 1e ALUMINIUM - CLMA - WEDGE GRIPS

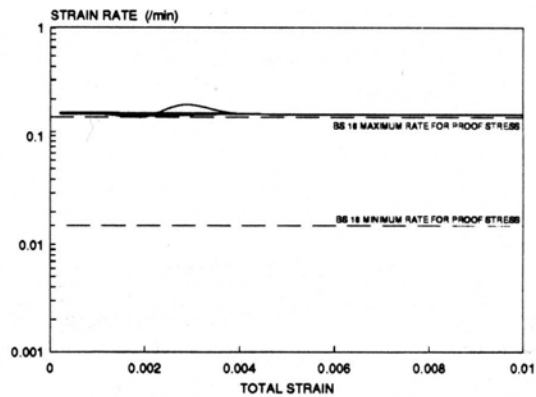


FIG 1f ALUMINIUM - CLHM - PIN GRIPS

Figure 25 - Strain rate vs Strain for extensometer control strain rate = 0.15/min

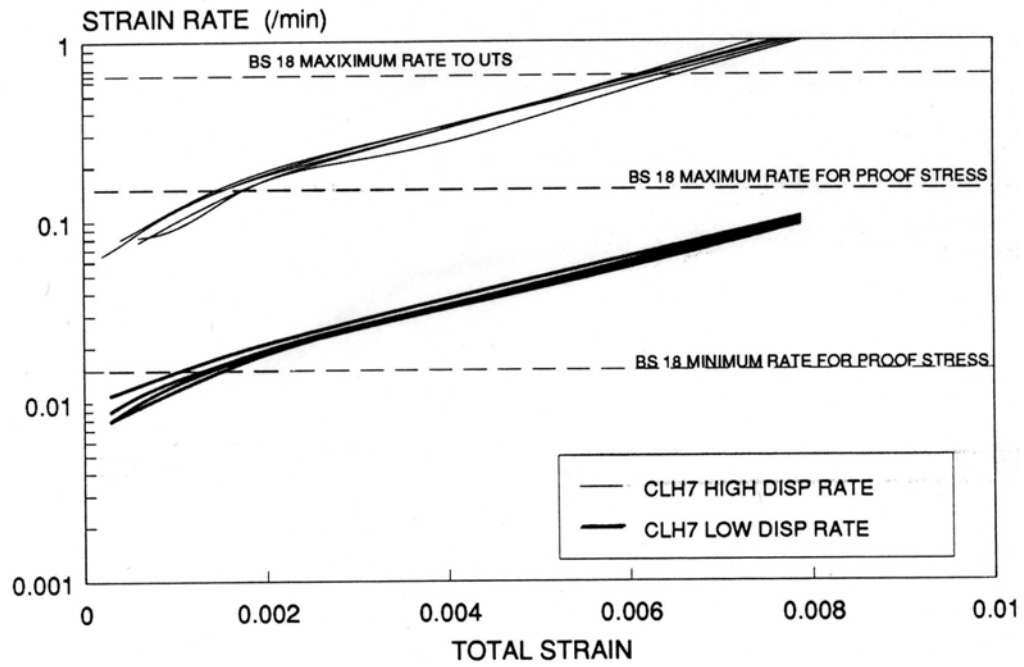


Figure 26 - Strain rate vs Total strain for plain end brass tensiles – Displacement rate control

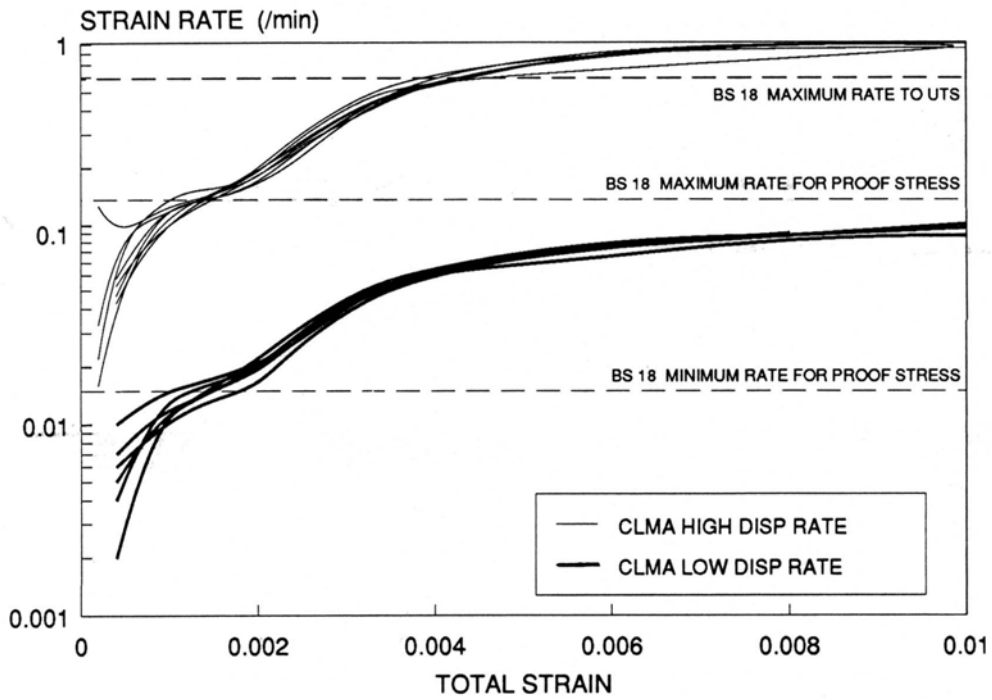


Figure 27- Strain rate vs.Total strain for Aluminum tests in Wedge Grips

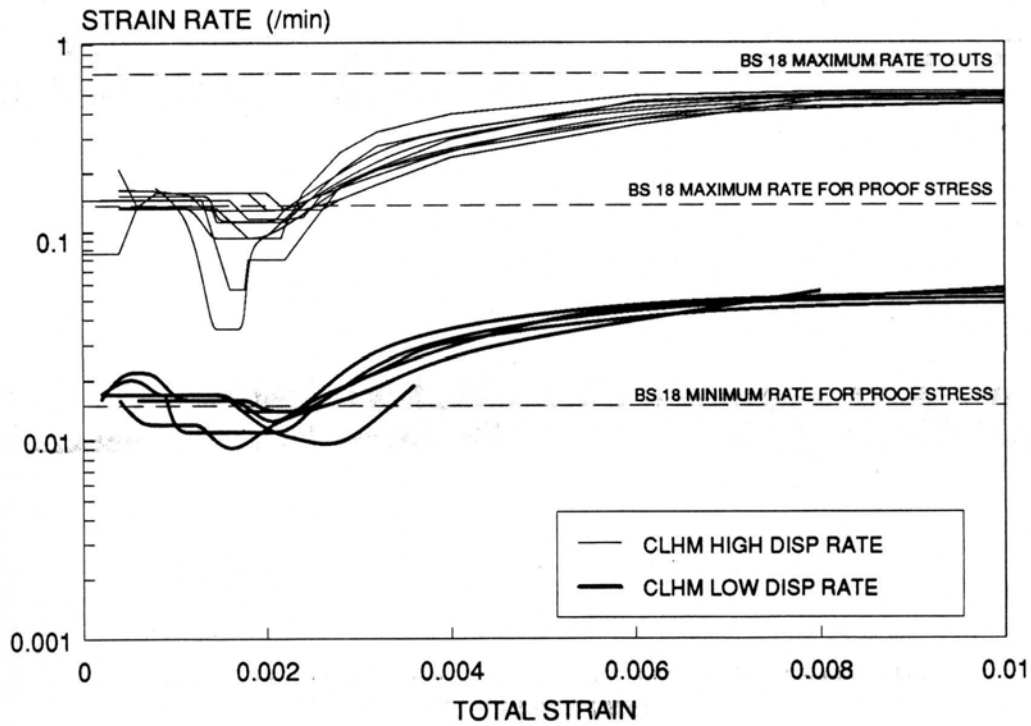


Figure 28 - Strain rate vs Total strain for Aluminium alloy in Pin Grips

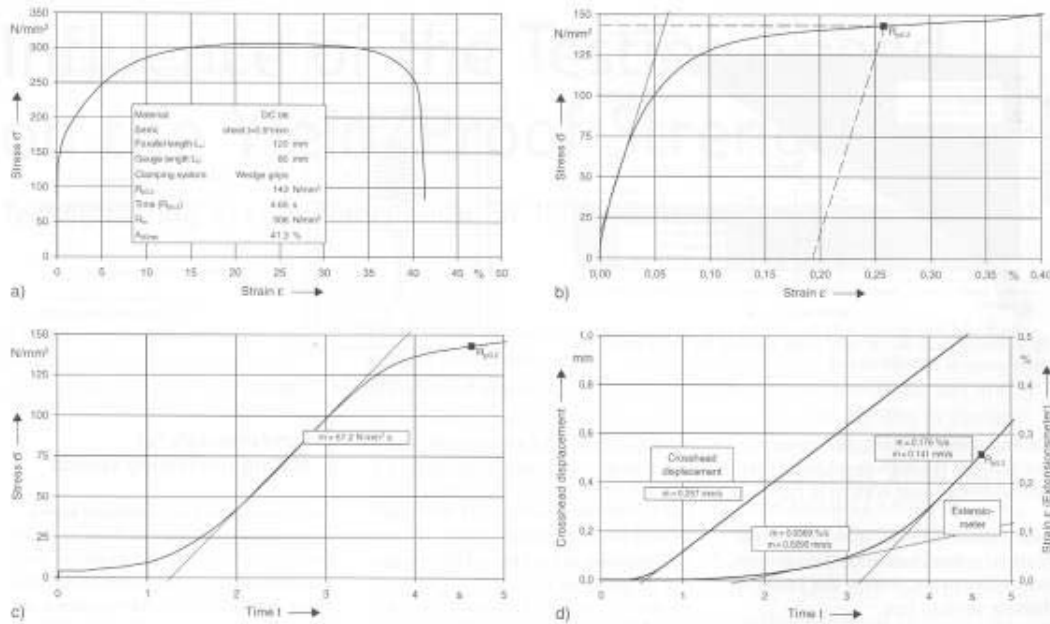


Figure 29. Tensile Test with preset traverse speed and low stiffness configuration ; a) stress- strain, b) stress – strain (elastic range & $R_{p0.2}$), c) stress-time, d) cross-head displacement and strain-time (note the big increase of the strainrate by a factor of 4.8) [Aegerter et al , 2001)

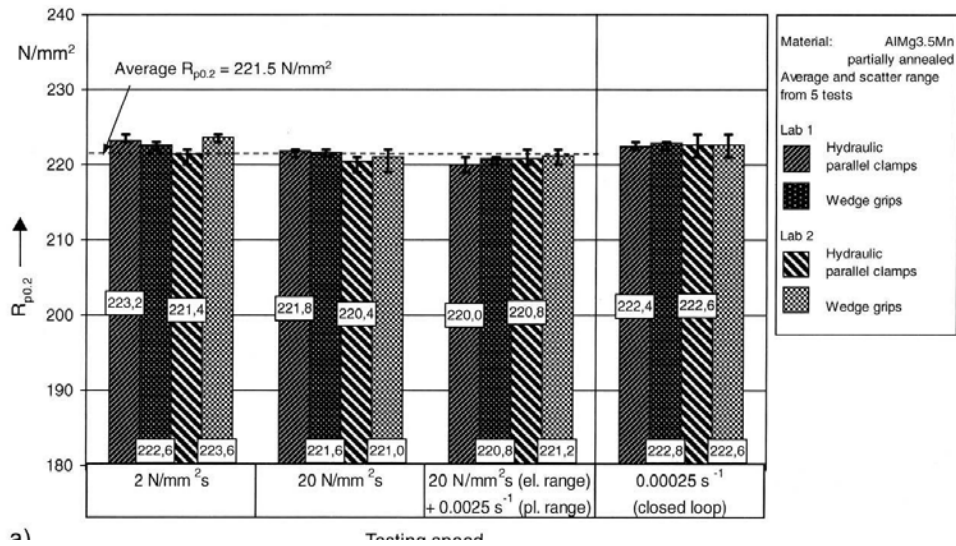


Figure 30 Results of $R_{p0.2}$ according to the testing speed and clamping system – $R_{p0.2}$ absolute

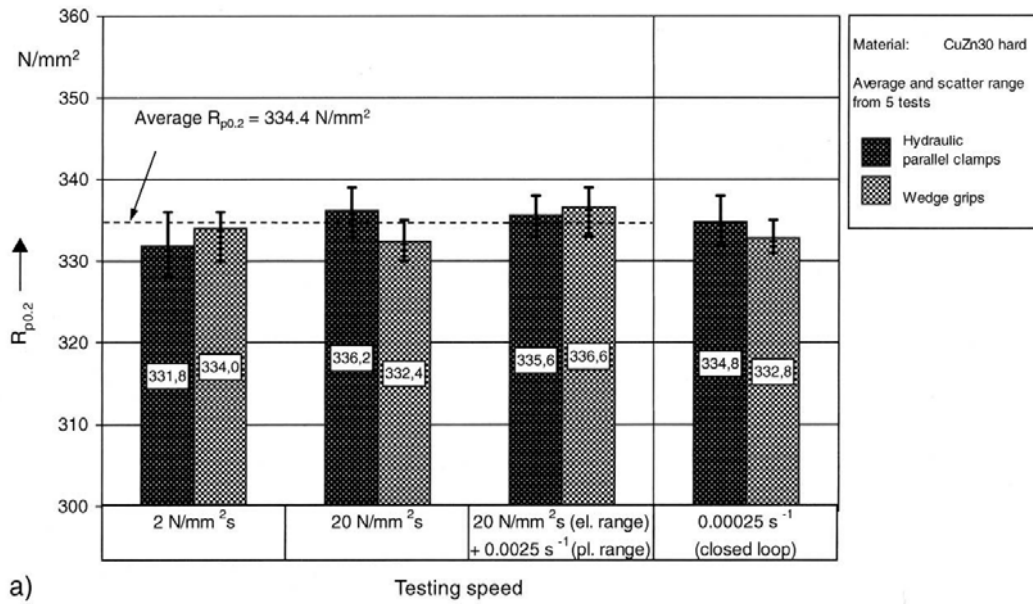


Figure 31 - Results of $R_{p0.2}$ according to the testing speed and clamping system – $R_{p0.2}$ absolute

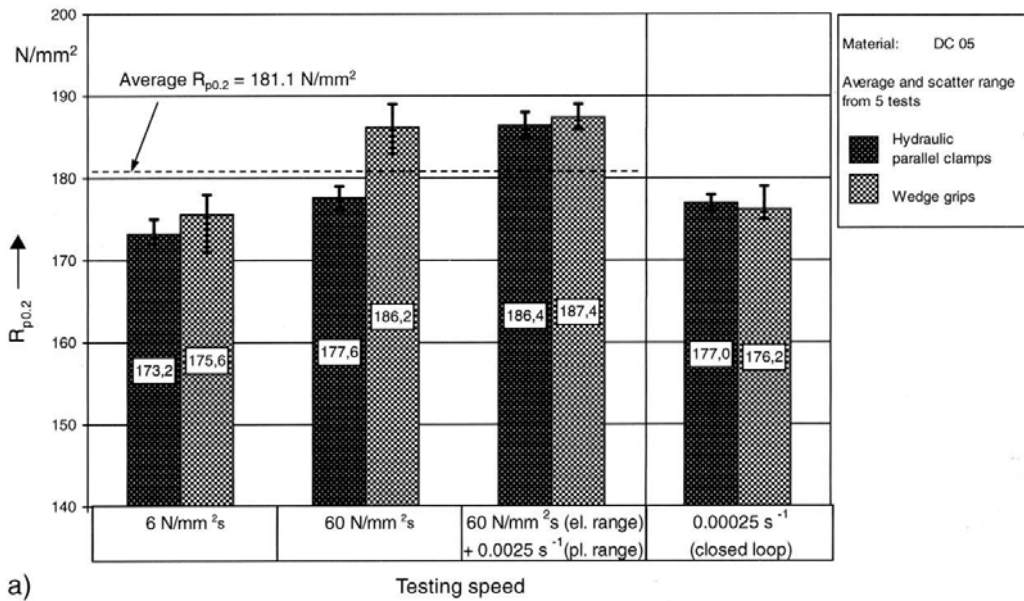


Figure 32 - Results of $R_{p0.2}$ according to the testing speed and clamping system – $R_{p0.2}$ absolute

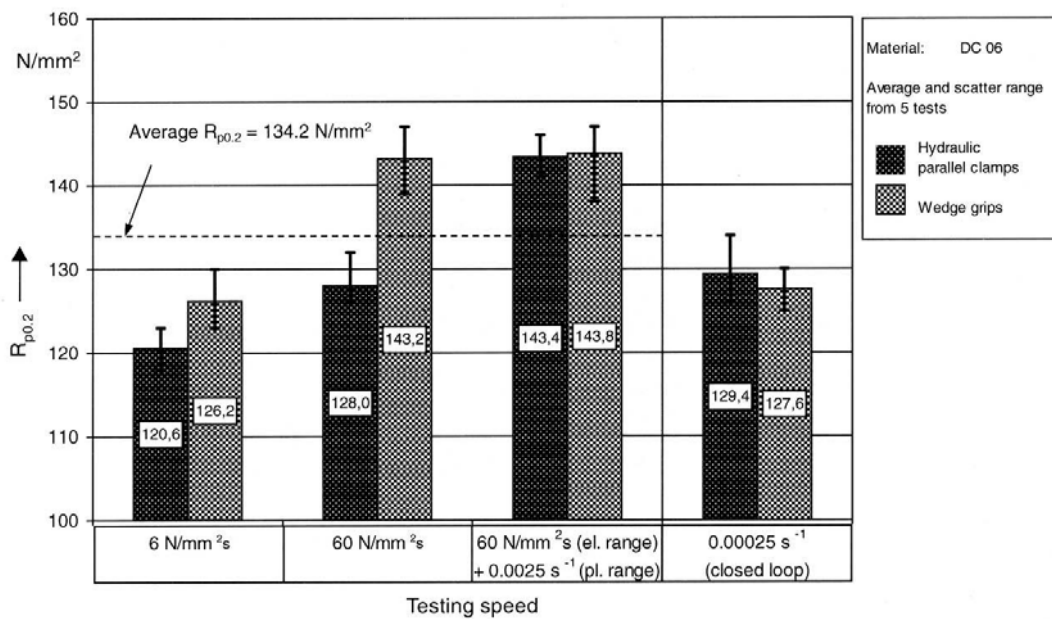
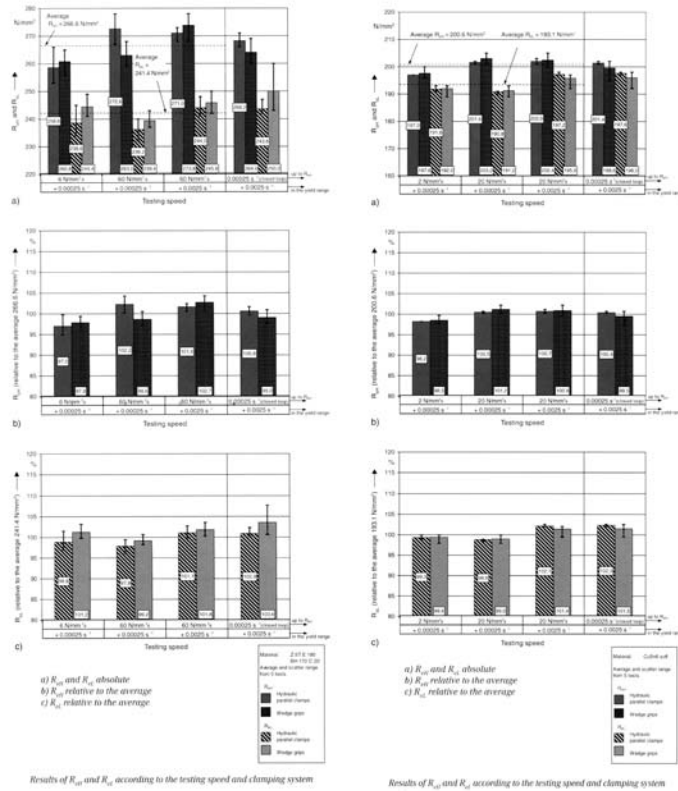


Figure 33 - Results of $R_{p0.2}$ according to the testing speed and clamping system – $R_{p0.2}$ absolute



Effect of testing speed and clamping system - yield drop material

Figure 34 [Aegerter et al, 2001]

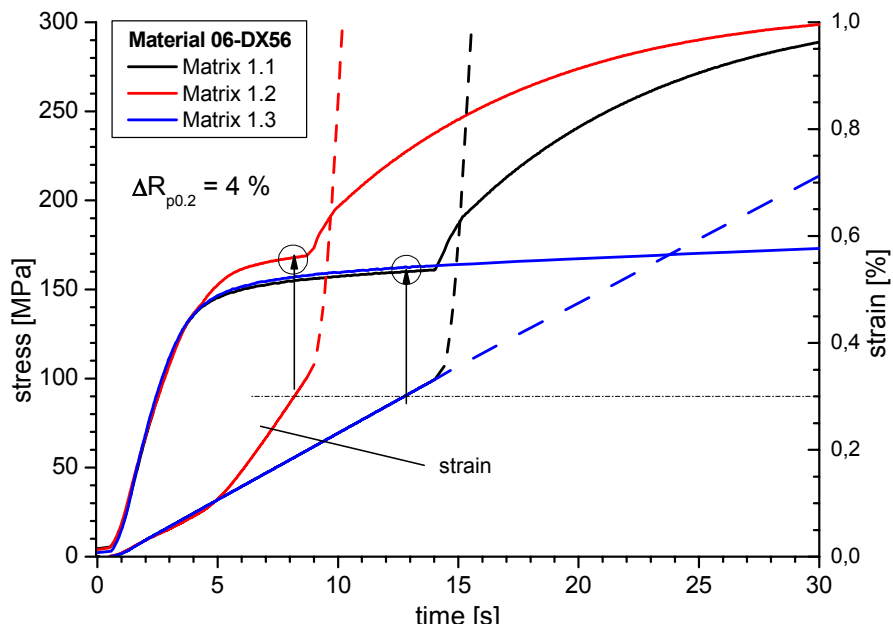


Figure 35 Diagram showing 4% difference in proof stress between strain-rate control & cross head control, from the TENSTAND project . Diagram prepared by Sigmar Ledworuski, [Klingelhöffer et al (BAM) 2004]

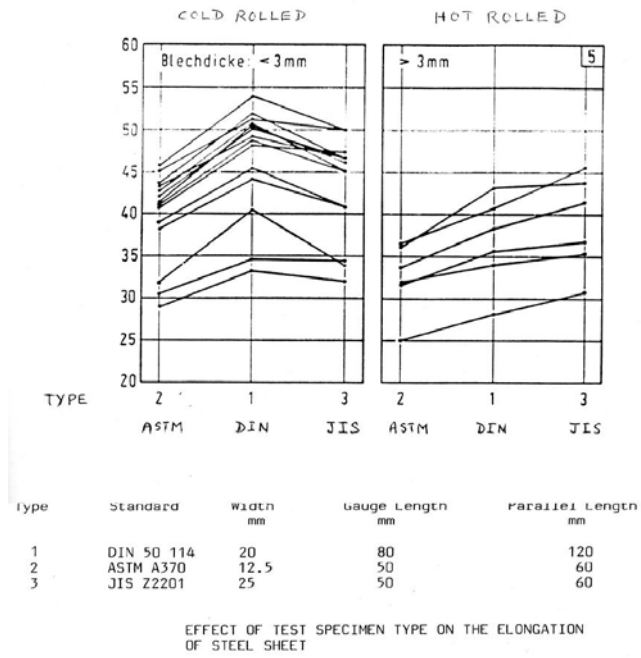


Figure 36 Effect of Test Specimen Type on the Elongation of Sheet Steel (Sonne et al (1983)

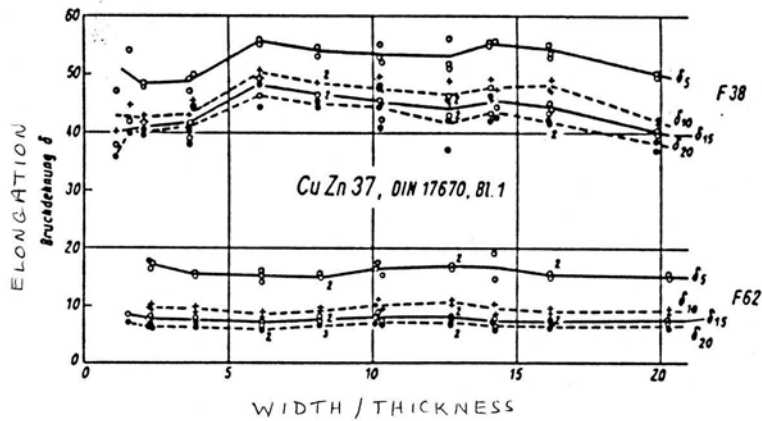
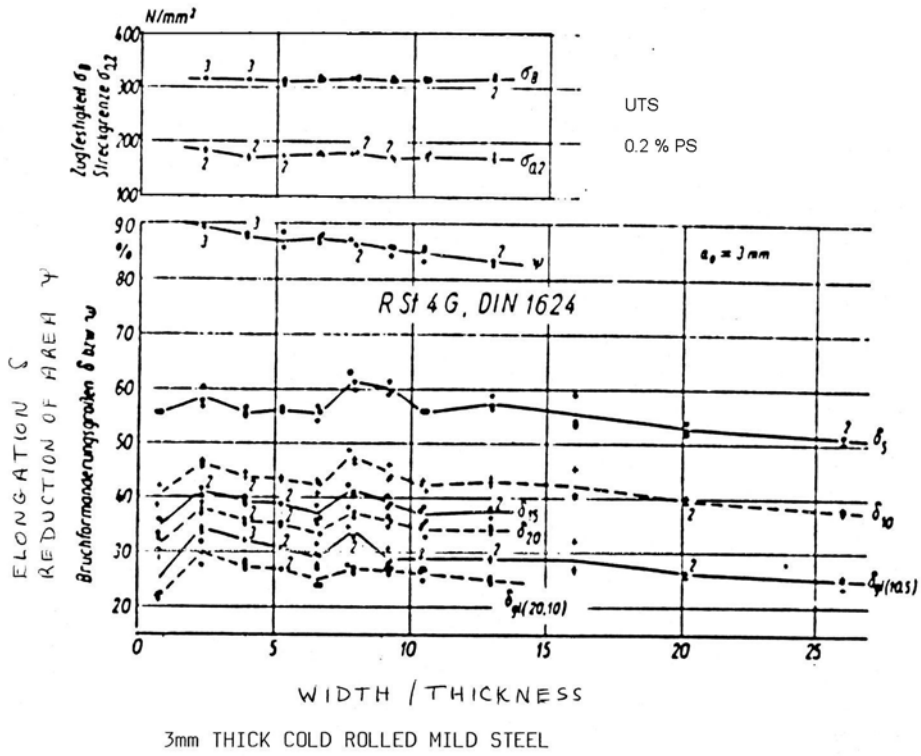


FIG 3b : 2mm THICK COLD ROLLED CuZn37 BRASS

5	gauge length	=	5.65 $\sqrt{A_0}$
10			11.3 $\sqrt{A_0}$
15			16.95 $\sqrt{A_0}$
20			22.6 $\sqrt{A_0}$

THE EFFECT OF WIDTH/THICKNESS ON THE STRENGTH AND ELONGATION OF MILD STEEL AND BRASS

Figure 37 - - The Effect of Width/Thickness on the Strength and Elongation of Mild Steel and Brass (Helms (1975))

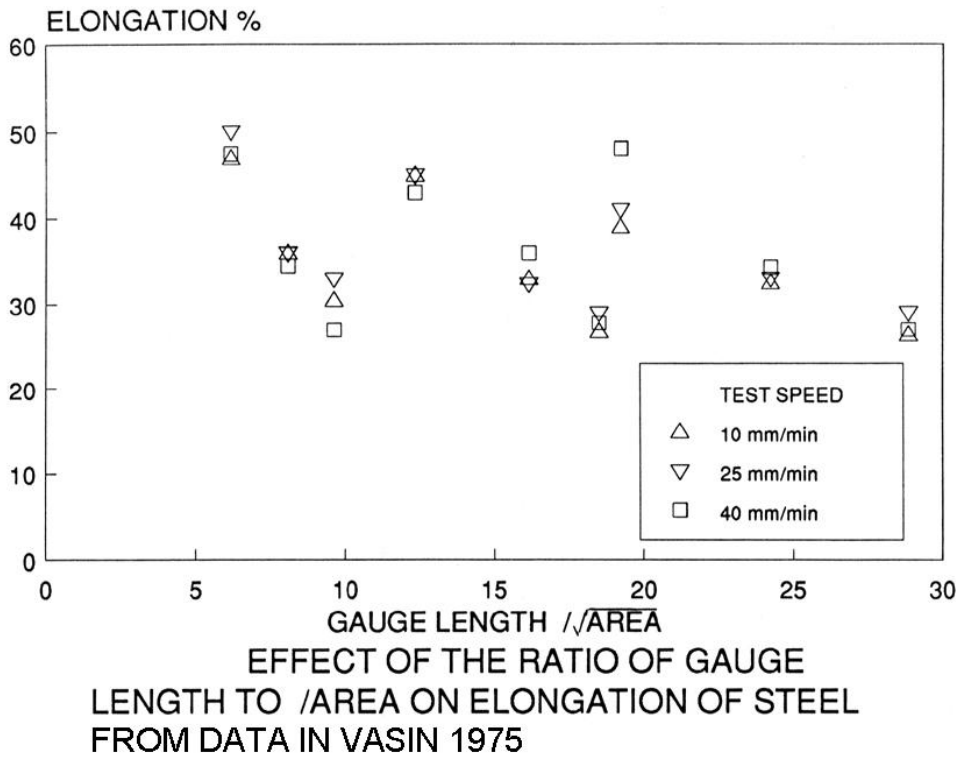


Figure 38 - Effect of the Ratio of Gauge Length to Area on Elongation of Steel (from data in Vasin (1975))

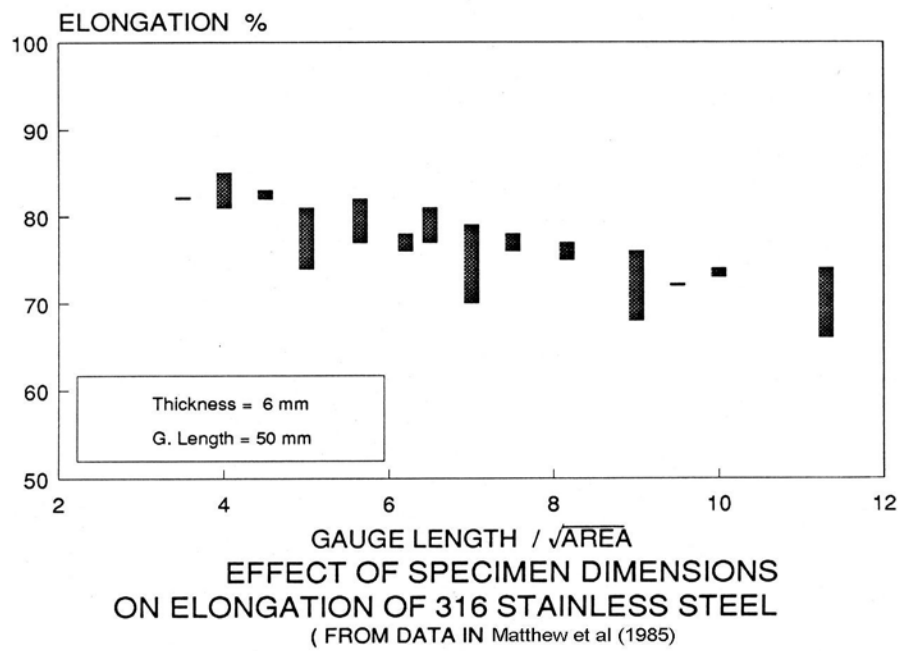
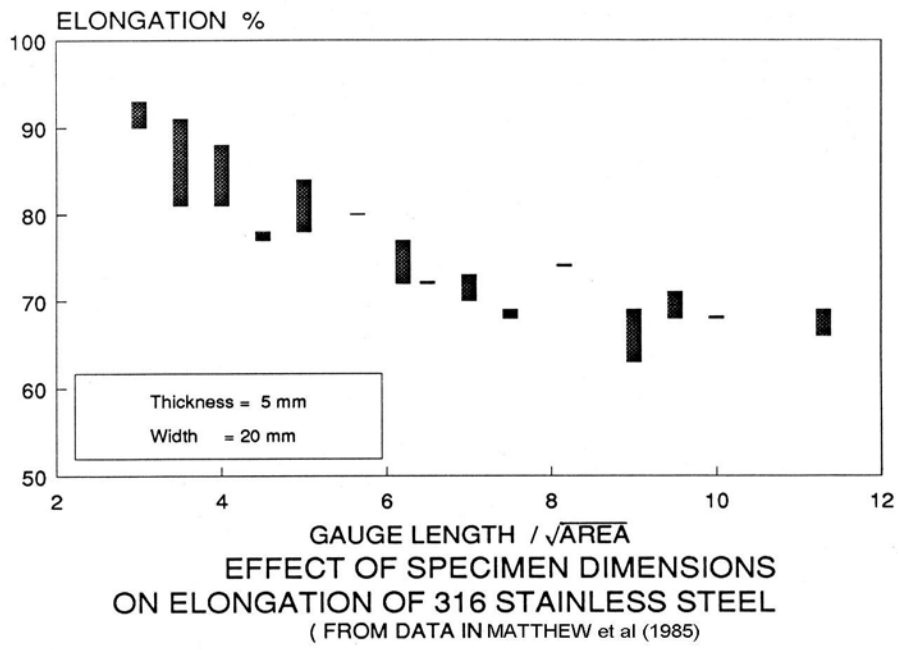


Figure 39

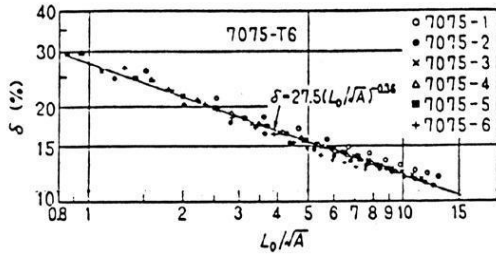


Fig. 6a Elongation percentage plotted by L_0/\sqrt{A} on log-log paper for 7075-T6 alloy.

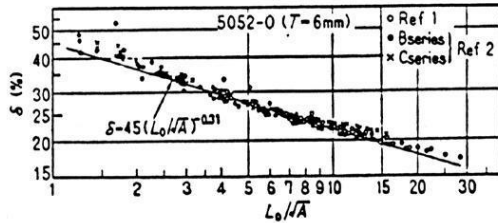
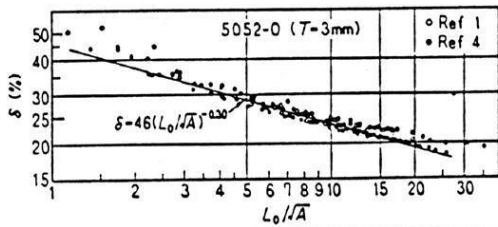


Fig. 6b Elongation percentage plotted by L_0/\sqrt{A} on log-log paper for 5052-0 alloys.

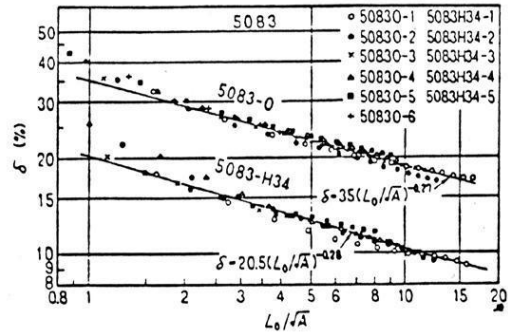


Fig. 6c Elongation percentage plotted by L_0/\sqrt{A} on log-log paper for 5083 alloys.

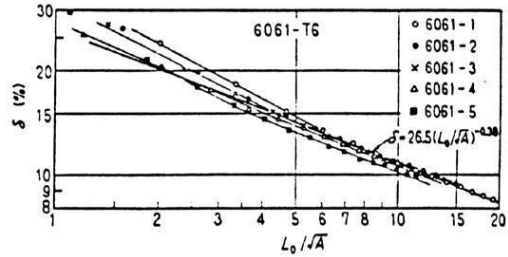


Fig. 6d Elongation percentage plotted by L_0/\sqrt{A} on log-log paper for 6061-T6 alloy.

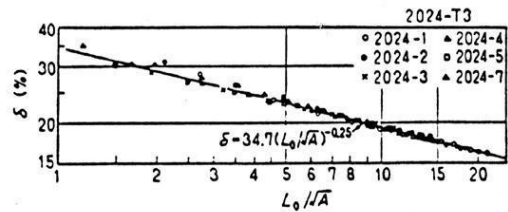
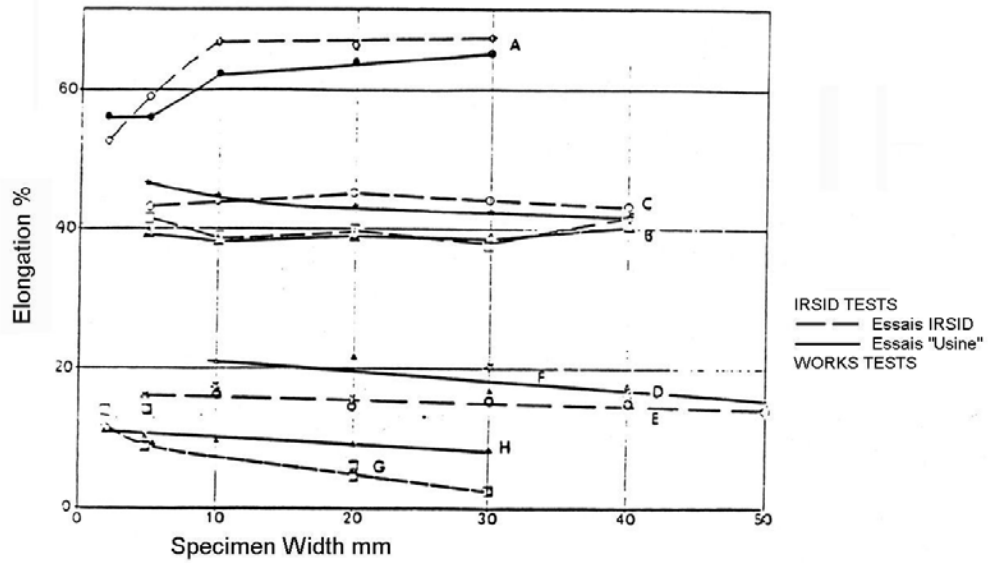


Fig. 6e Elongation percentage plotted by L_0/\sqrt{A} on log-log paper for 2024-T3 alloy.

6(a)-(e) : EFFECT OF GAUGE LENGTH/ $\sqrt{\text{AREA}}$ ON ELONGATION OF ALUMINIUM ALLOYS

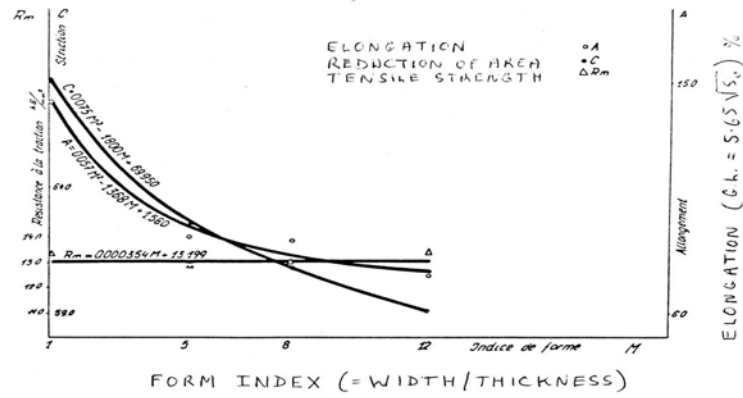
Figure 40- Sato (1973)



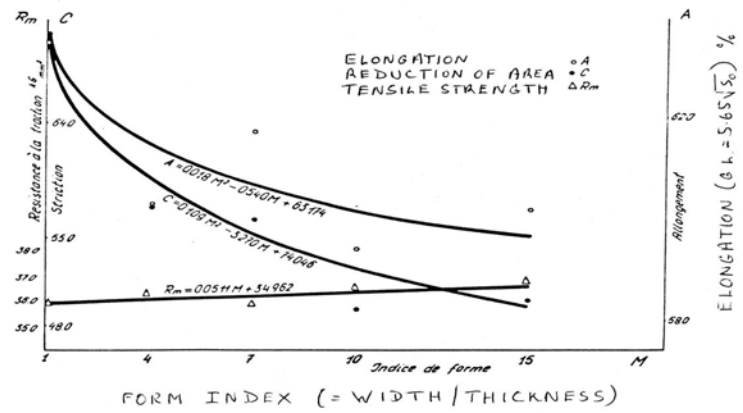
- A extra mild steel
- B,C mild steel
- D,E,H quenched and tempered steel
- F control rolled steel
- G maraging steel

ELONGATION (GAUGE LENGTH = $5.65 \sqrt{\text{AREA}}$)
 AS A FUNCTION OF TEST SPECIMEN WIDTH

Figure 41- Grumbach (1977)



EFFECT OF FORM INDEX ON THE TENSILE PROPERTIES OF 5mm THICK ALUMINIUM



EFFECT OF FORM INDEX ON THE TENSILE PROPERTIES OF 8mm THICK BRASS (Misiolek (1971))

Figure 42 geometry effects in brass and aluminium

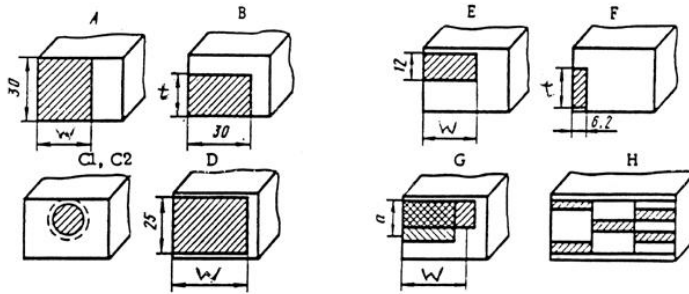
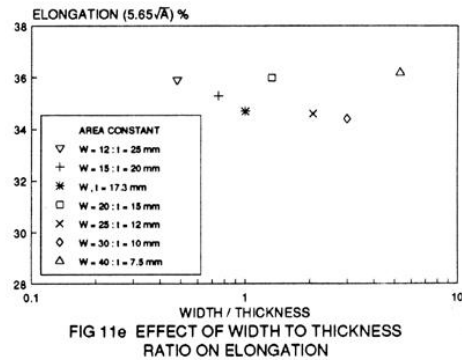
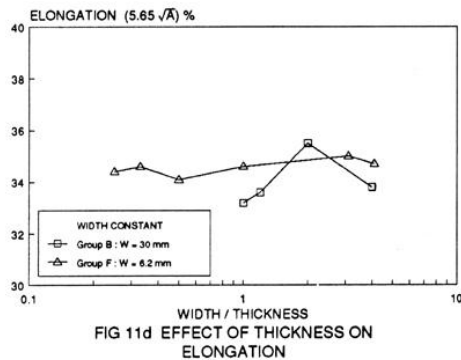
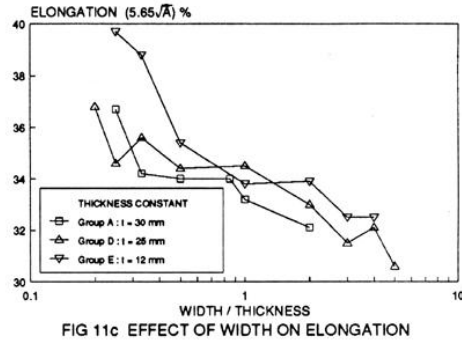
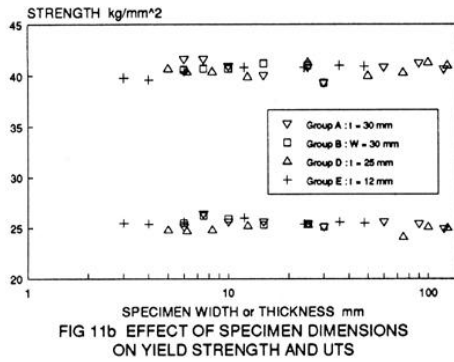
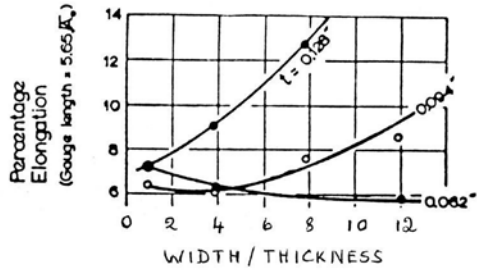


Fig.11a Schematic diagram showing specimens of different series; shading indicates the cross-sectional areas of specimens.

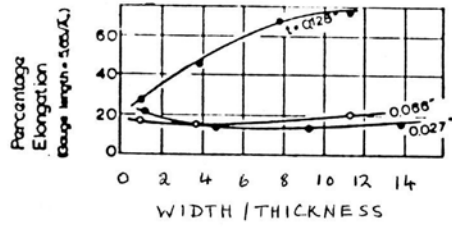


EFFECT OF SPECIMEN GEOMETRY ON THE TENSILE PROPERTIES OF STEEL

Figure 43 - a-e Effect of Specimen Geometry on the Tensile Properties of Steel From data in Grumbach et al (1977)



a : MILD STEEL



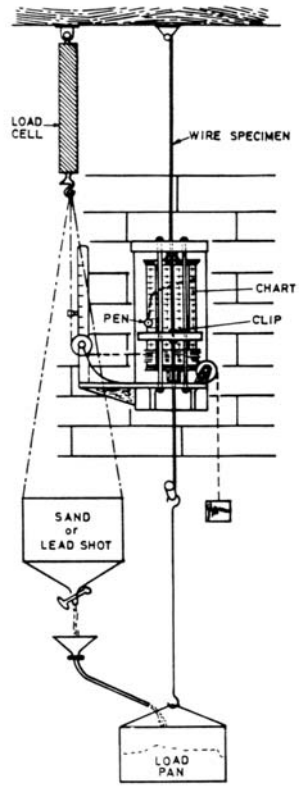
b : ALUMINIUM

a, b : VARIATION IN ELONGATION WITH RESPECT TO WIDTH-TO-THICKNESS RATIO (HSU et al)

Figure 44 - Variation in Elongation with respect to Width to Thickness Ratio (Hsu et al (1965))

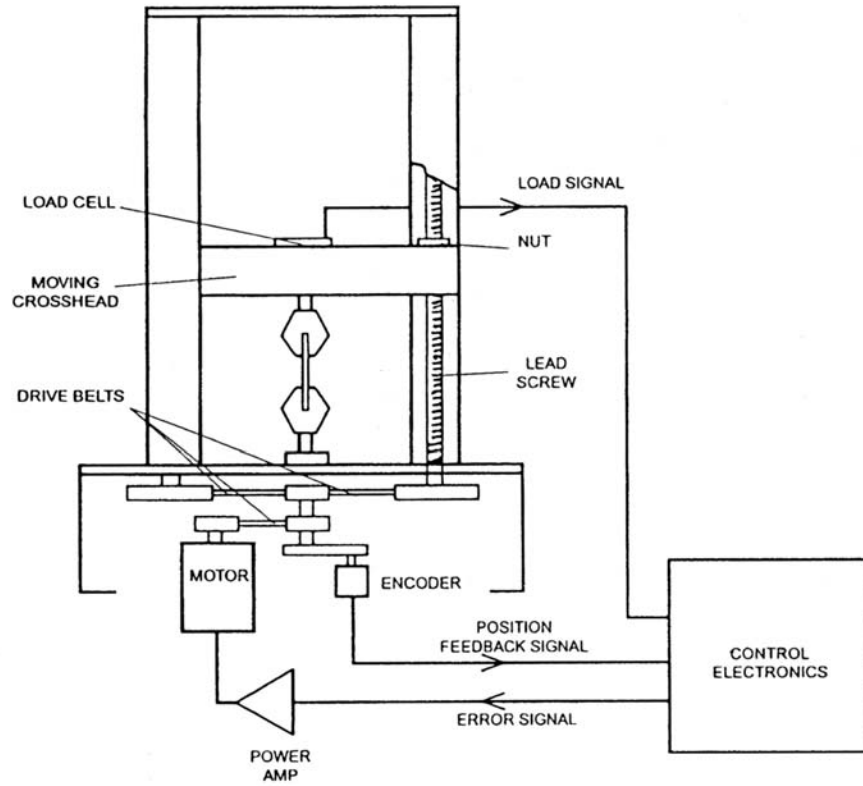


Figure 45. High stiffness research tensile testing machine developed at BAM capable of straining testpieces down to a very fine point (Markowski, 1991)



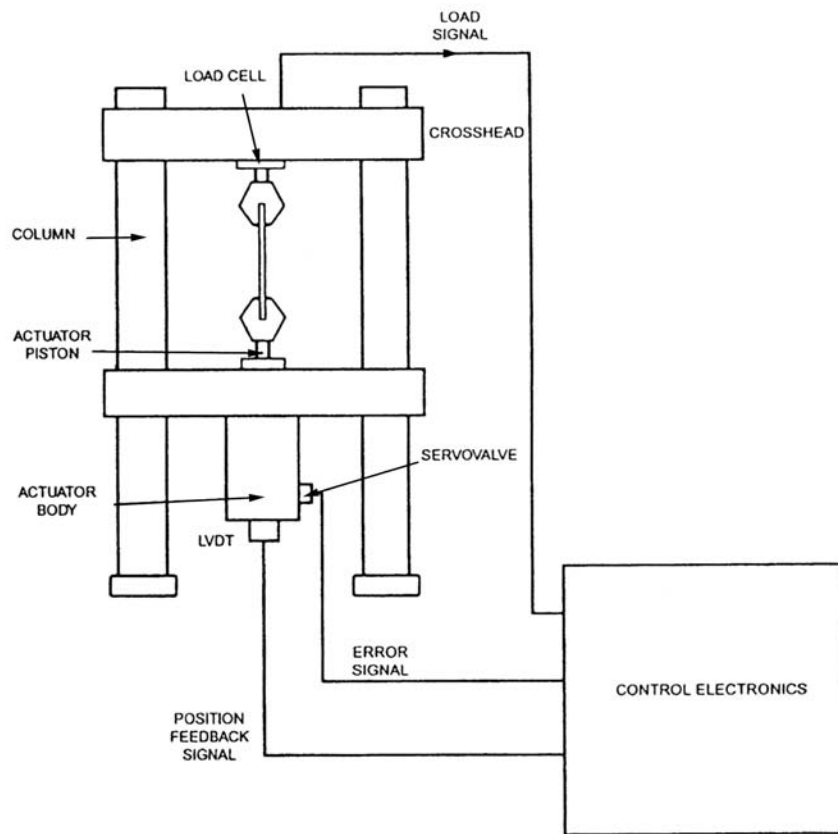
Barr's autographic wire tester

Figure 46



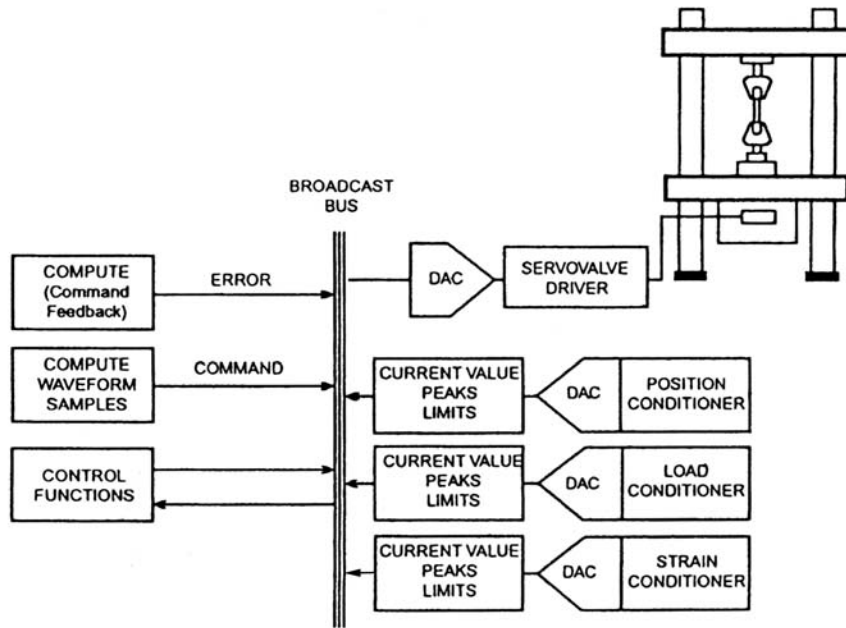
Electromechanical testing machine

Figure 47 – machine schematic



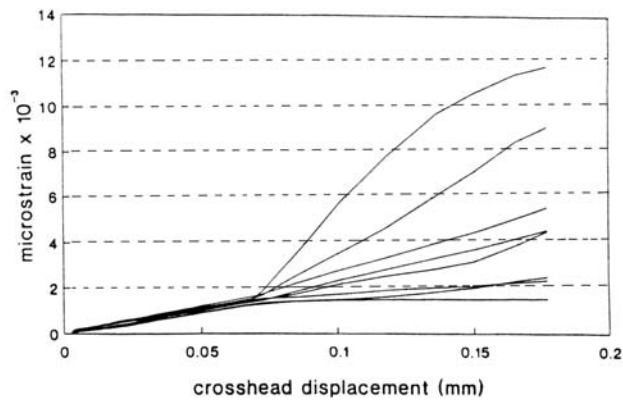
Servohydraulic testing machine

Figure 48 – machine schematic



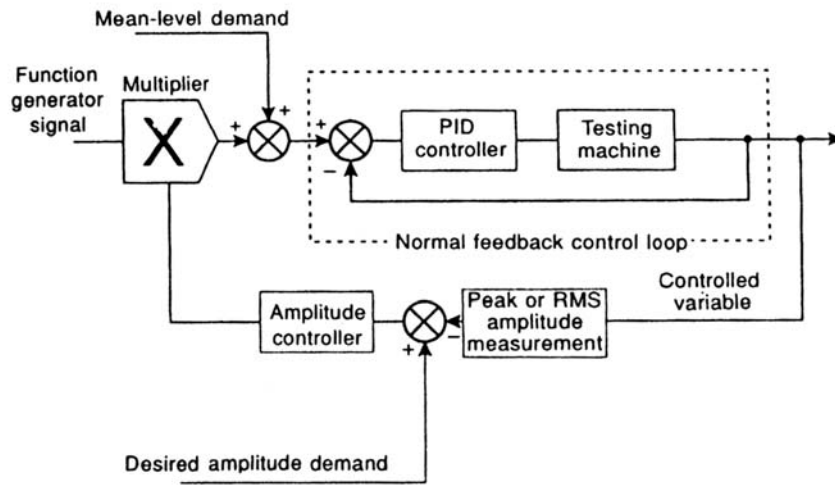
Digital control loop

Figure 49 – schematic of digital control system



Variation in strain along gauge length

Figure 50 – results of test on strain-gauged specimen



Outer - loop control

Figure 51

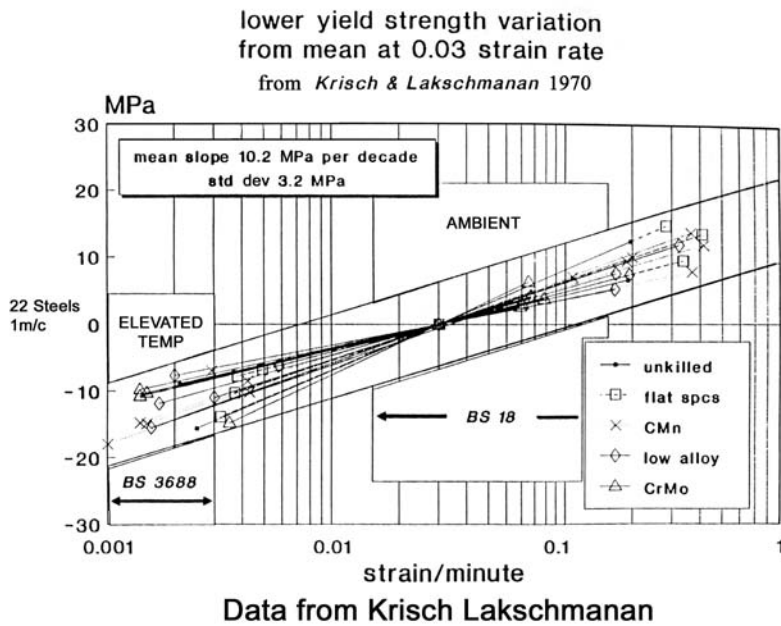
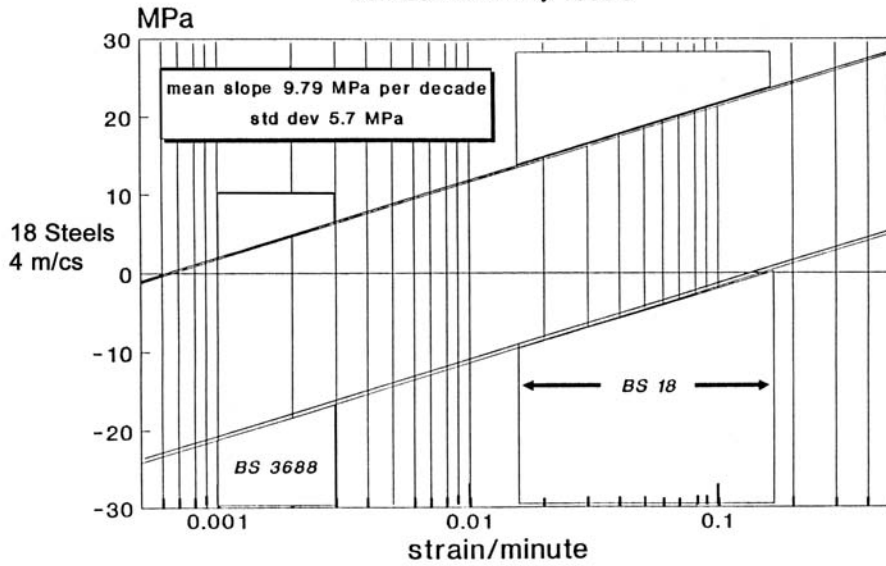


Figure 52– effect of testing rate on LYS

0.2% proof and lys variation
from mean at 0.01 strain rate

Johnson & Murray 1960's



Variation in yield strength

Figure 53 range of data – 18 UK steels

lower yield strength variation
from mean at 0.1 strain rate 1960's

Johnson

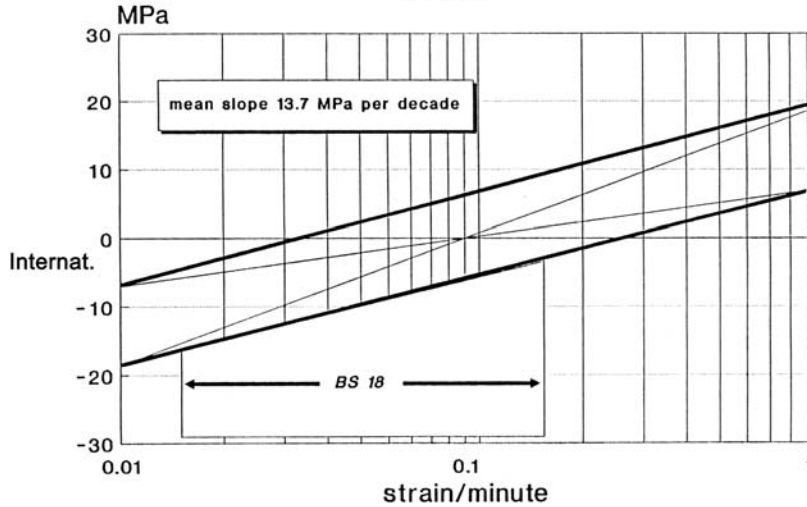
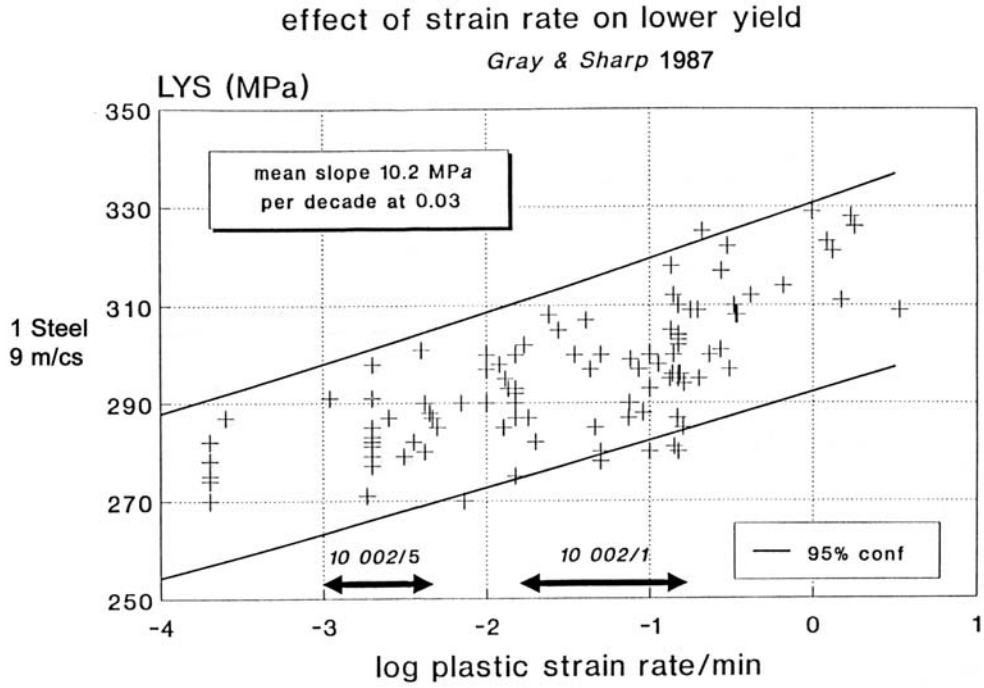


Figure 54 – international data 21 labs 5 countries



Variation over several machines

Figure 55 – range of data for single steel

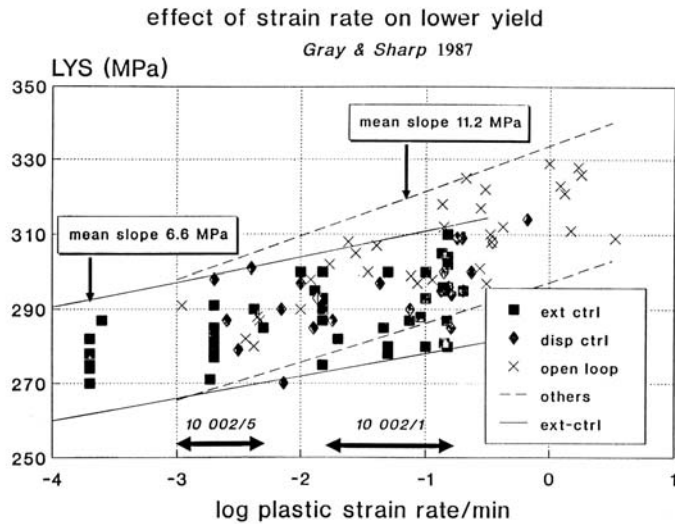
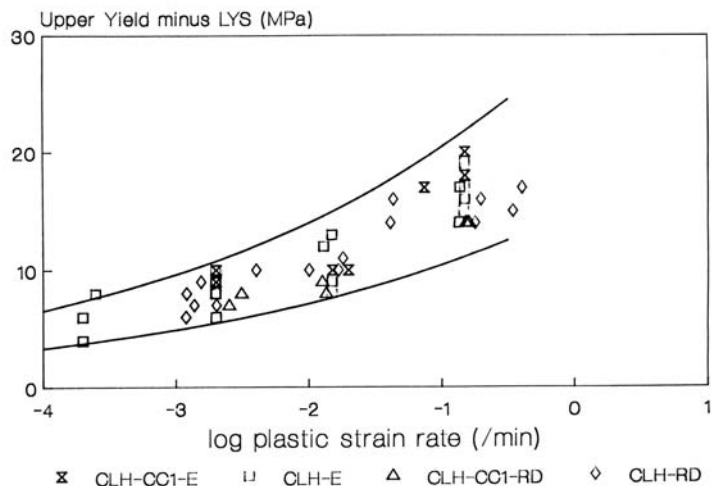
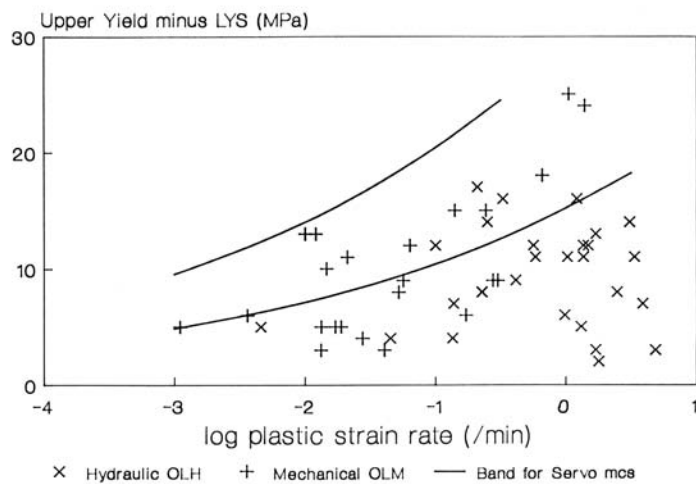


Figure 56 effect of testing system –single steel



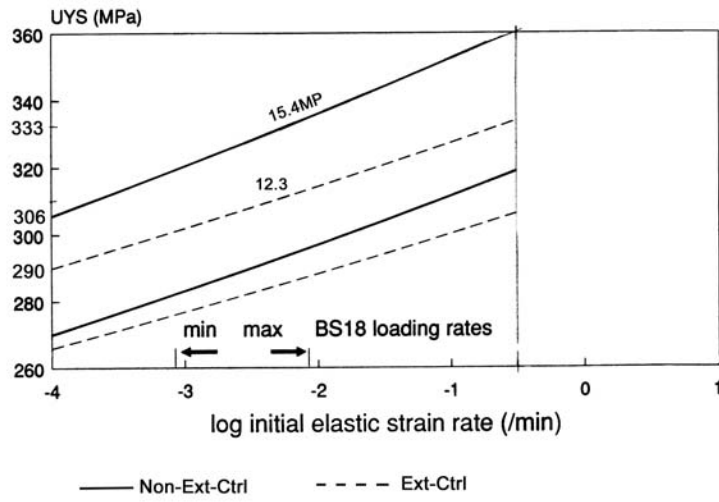
Yield Drop - Servo Machines

Figure 57 – effect of control system



Yield Drop - Open-Loop Machines

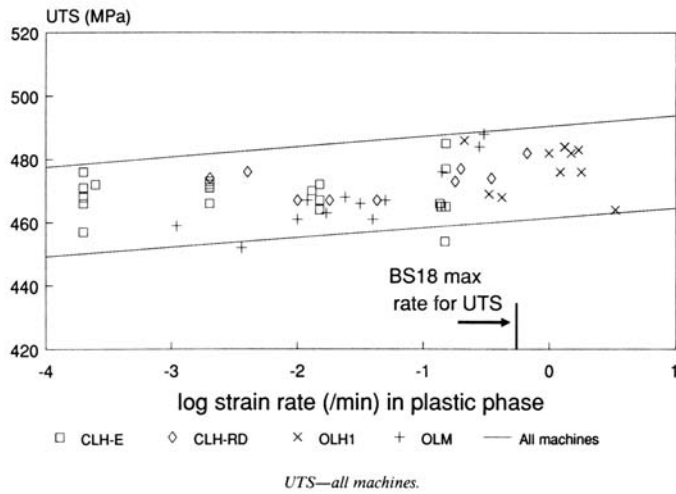
Figure 58 – effect of machine type and control



UYYS -influence of extensometer feedback

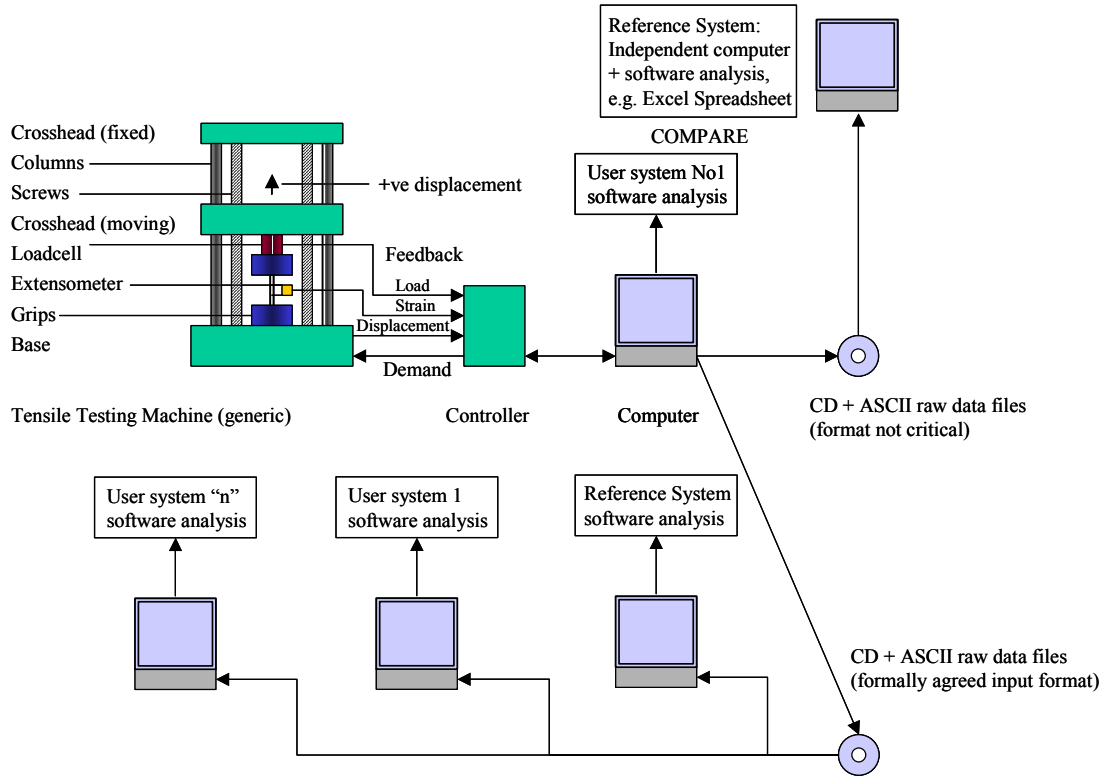
Comparison of control methods on upper yield strength

Figure 59 – results from single steel



Effect of strain rate on UTS

Figure 60 results from single steel



R. D. Lohr
Sept ember 2001

Figure 61 Schematic diagram showing the concepts behind using agreed ASCII data files for validating tensile testing software.

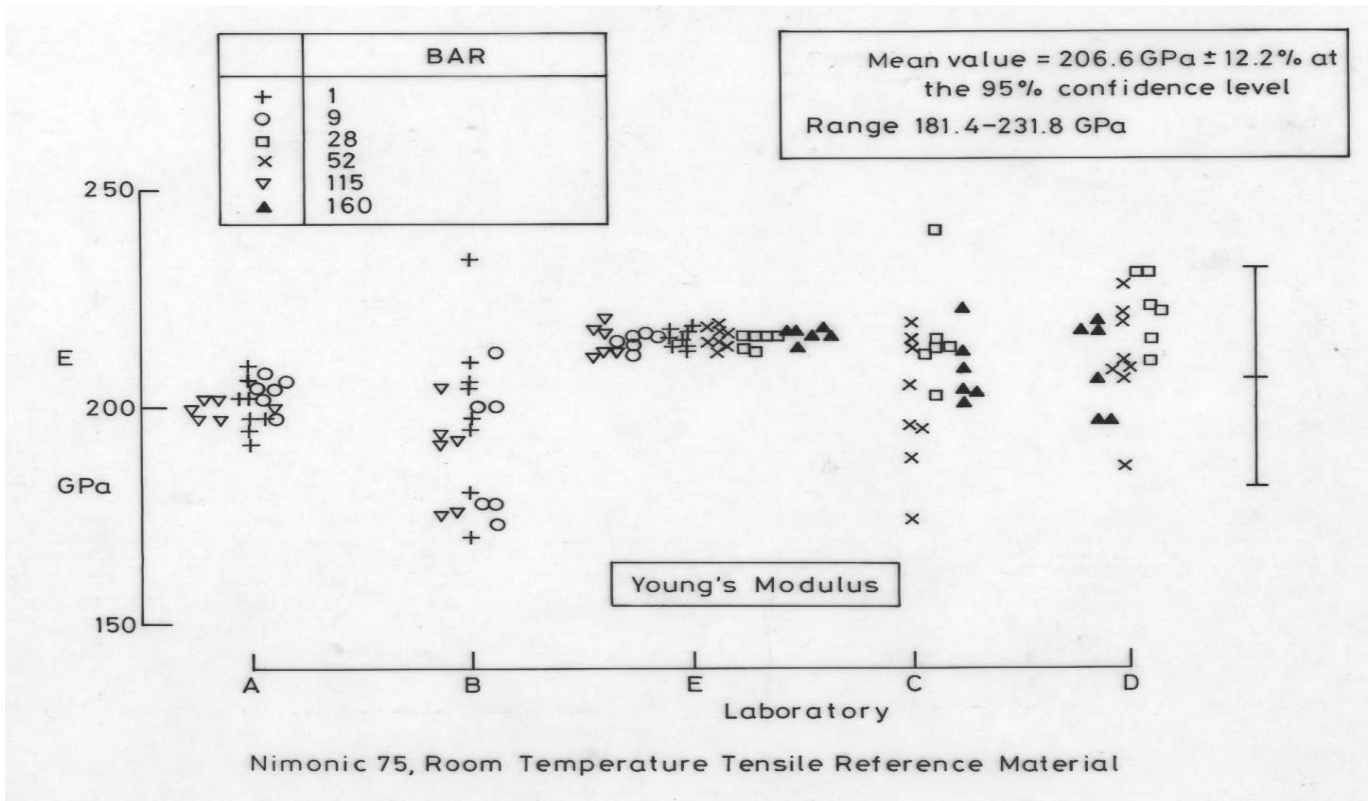


Figure 62. Typical scatter encountered in the measurement of Young's Modulus in the tensile test carried out in accordance with EN10002 Part1. Laboratories A-D used single sided Class 1 extensometers. Laboratory E used a special high resolution side-to-side averaging extensometer. [Ingelbrecht & Loveday, 2000]

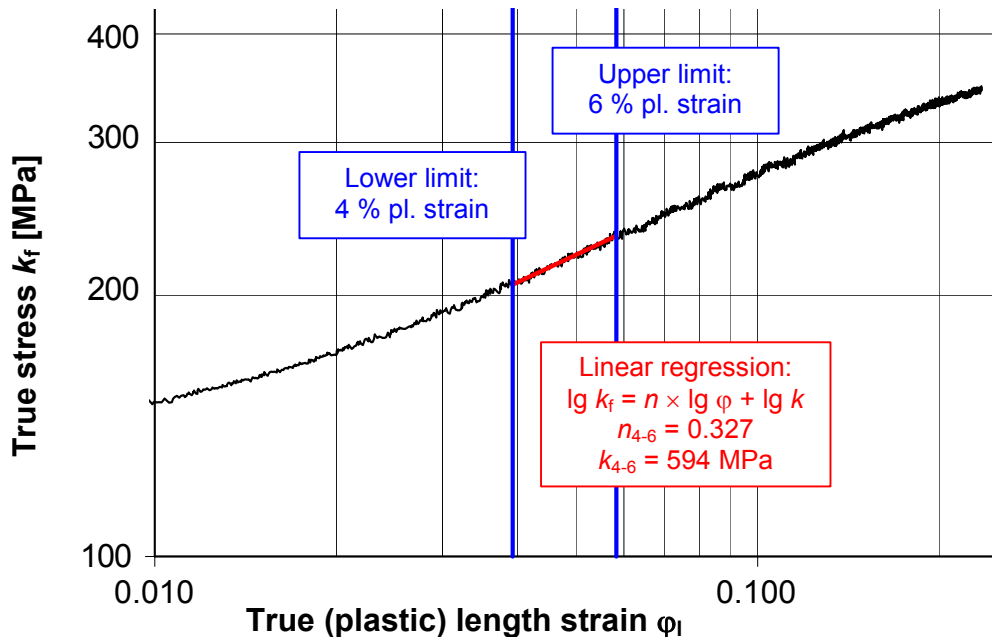


Fig. 63 : Double logarithmic true stress k_f vers. true (plastic) strain ϕ_l curve with best fit straight line for determination of n_{4-6}

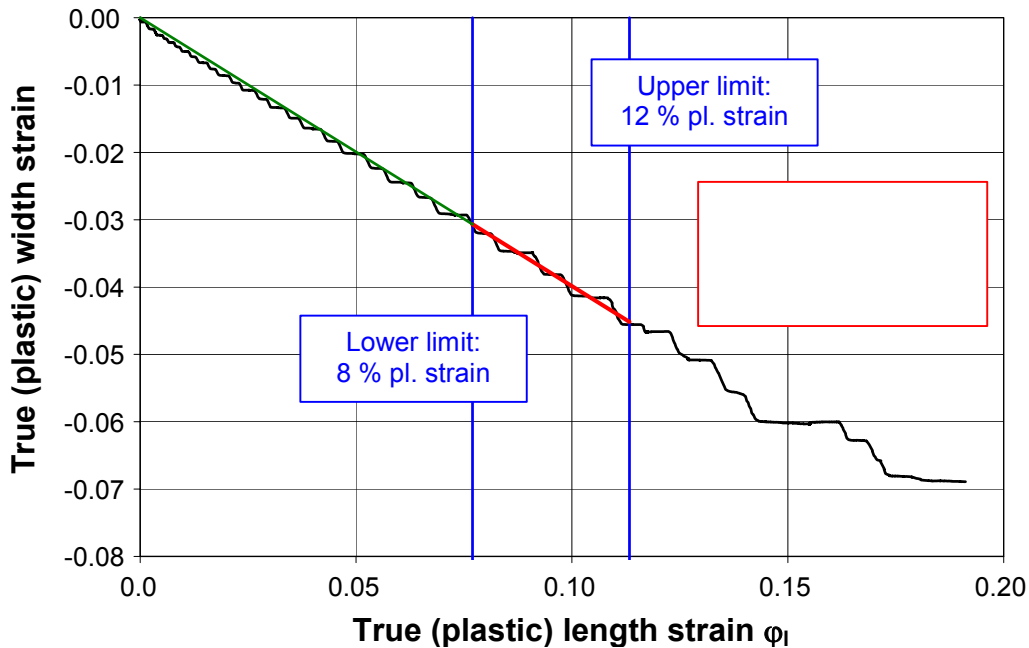


Figure 64: True (plastic) width strain ϕ_b vers. true (plastic) length strain ϕ_l curve with best fit straight line for determination of r_{8-12}

APPENDIX 1. List of Papers relating to Tensile Testing compiled during TENSTAND Project

TENSTAND List of References & Relevant Literature		Year
1	The Testing of Materials of Construction' 1910. W.C.Unwin, Longmans, Green & Co., New York, Bombay & Calcutta. (excellent source of data on early tensile testing , including Modulus measurements)	1910
2	Method for Converting Elongation Values for Steel - Carbon and Low Alloy Steels / Anon, BS 3894 : Part 1 1965	1965
3	The Effect of Rate of Straining on the 0.2% Proof Stress and Lower Yield Stress of Steel / Johnson, RF ; Murray JD ; BISRA/1st conference 1966	1966
4	The Measurement of Yield Stress / Johnson, RF ;ISI Publication 104 BISRA/ISI Conference 1967	1967
5	Der Einfluss von Geschwindigkeit und Prüfmaschine auf Streckgrenze und Zugfestigkeit von Stahl / Krisch, A ; Lakshmanan, R ; Forschungsberichte NordRhein WestFalen, WestDeu. Verlag 1970 No.2069	1970
6	Ueber das verhalten der staehle bei zugbeanspruchung unterhalb der oberen streckgrenze. KRAVCENKO-V. Zeitschriftenaufsatz: Materialprüfung, Band 12 (1970) Heft 11, Seite 373- 377 (4 Bilder, 23 Quellen)	1970
7	Der Einfluß der Geschwindigkeit und Prüfmaschine auf Streckgrenze und Zugfestigkeit von Stahl / A. Krisch und R. Lakshaman, Westdeutscher Verlag; Köln (1970)	1970
8	The Tensile Testing Technique. Influence of Test Conditions on the Level of Measured Characteristics / Mathonet, J ; Caubo, M ; Metallurgical Reports CRM26 1971 pp31-38	1971
9	Some mechanical characteristics of testing machines and their influence on the response of test specimens / A.J. Carmichael et al; the institution of engineers (Australia) (1971)	1971
10	DER EINFLUSS DER PRUEFMASCHINENHAERTE AUF DIE ERGEBNISSE DES ZUGVERSUCHS. LANGE-G. TU BRAUNSCHWEIG. Zeitschriftenaufsatz: ARCH. EISENHUETTENWES., Band 43 (1972) Heft 1, Seite 67-75 (9 Seiten, 11 Bilder, 1 Tabelle, 19 Quellen)	1972
11	Influence of the Hardness of the Testing Machine on the Results of the Tensile Test / Lange, G ; Archiv Eisenhüttenwesen 1972 Vol.43, No.1	1972
12	Some Mechanical Characteristics of Testing Machines and their Influence on the Response of Test Specimens / Carmichael, AJ ; Betz, E ; Inst Engineers Australia, Mech Chem Eng Trans 1972 MC8(1) pp 100-103	1972

13	Einfluss der Probenabmessungen auf die Bruchdehnungswerte beim Zugversuch an Blechen und Baendern. Helms-R. BAM Berlin. Zeitschriftenaufsatz: Bänder Bleche Rohre, Band 16 (1975) Heft 6, Seite 241-244,253 (5 Seiten, 6 Bilder, 16 Quellen)	1975
14	Alignment problems in the tensile test / Christ, BW ; Swanson SR Journal of Testing and Evaluation 1976 4, pp405-417	1976
15	Determination of Material Behaviour in Tensile Tests using Hydraulic Testing Machines / Hass, T ; Society Environmental Engineers Journal 1976 pp11	1976
16	Die Spannungs-Dehnungskurve von Stahl / Dahl, W ; Rees, H ; Verlag Stahleisen, Dusseldorf 1976	1976
17	Effect of Rigidity of Testing Machines on the Behaviour of Tensile Deformation in Mild Steel / Tenaka, Ishikawa, H ; Proc. 19th Japan Congress ISI, Scarborough 1976	1976
18	Effects of misalignment on the pre-macroyield region of the uniaxial stress-strain curve / Christ, BW ; Metallurgical Transactions 1973 4, 1961-65	1976
19	Rational Basis and New Methods for Proportional Limit, Velocity Measurements Machine Stiffness, Critical Stress Intensity, and Crack / Clough, RB ; Recent Developments in Mechanical Testing, ASTM STP 608 1976 pp 20-44	1976
20	Rational Basis and new methods for proportional limit, machine stiffness, critical stress intensity and crack velocity measurements / Clough, R.B.; ASTM STP 608 (1976), pp20-44.	1976
21	Effect of Specimen Taper and Machining Processes on Tension Test Results / Schmieder, AK ; Reproducibility and Accuracy of Mechanical Tests, ASTM STP 626 1977 pp 3-20	1977
22	Analysis of misalignment in the tensile test / Wu, HC ; Rummier, DR ; J.Eng.Mat.Technol., Trans. 1979 101, 68-74	1979
23	Untersuchungen ueber die Reproduzierbarkeit des Elastizitaetsmoduls im statischen Zugversuch. Research into the reproducibility of the modulus of elasticity during the static tensile test. Bauer-F; Aigner-H. Vereinigte Edelstahlwerke A G -VEW-, Ternitz, AT. Zeitschriftenaufsatz: Berg- Huettenmaenn. Monatsh., Band 126 (1981) Heft 3, Seite 73-80, With abstract in German, English and French (8 Seiten, 12 Bilder, 3 Tabellen)	1981
24	Variation of plastic strain ratio with strain level in steels. Variation des plastischen Dehnungsverhaeltnisses mit der Dehnungsstaerke in Staehlen. Arthey-R-P; Hutchinson-W-B. Birmingham Univ, GB; Aston Univ, Birmingham, GB. Zeitschriftenaufsatz: Metall. Trans., A, Band 12A (1981) Heft 10, Seite 1817-1822, With abstract in English (6 Seiten, 8 Bilder, 17 Quellen)	1981
25	High Temperature and time dependent mechanical testing ; an historical introduction.' 1982. M.S.Loveday, chapt 1, pp1-12, in 'Measurement of High Temperature mechanical properties of Materials' ed M.S.Loveday, M.F.Day & B.F.Dyson , Pub HMSO, London.	1982

26	Measurement of high temperature elastic modulus and linear expansion coefficient of metals / S. Tichkiewitch; Proceedings of the 7th international conference on experimental stress analysis, Haifa, Israel (1982), S. 274	1982
27	On the strain dependence of plastic-strain ratio of deep-drawing sheet steels. Ueber die Verformungsabhaengigkeit des plastischen Anisotropiefaktors von Tiefzieh-Blechstaehlen. Hu-H. United States Steel Corp, Monroeville, PA, US Applied Research Lab. Zeitschriftenaufsatz: Metall. trans. A, Band 14 (1983) Heft 7, Seite 1521-1523 (3 Seiten, 1 Bild, 1 Tabelle, 7 Quellen)	1983
28	Some Problems about Strain Hardening Exponent of Metals / Huang, M ; Lo, J , He, B ; In: Mechanical Behaviour of Metals IV 1983 Vol.2	1983
29	Influence of gage dimensions on elongation values for type 316 stainless steel. Einfluss der Pruefkoerperabmessungen auf die Verlaengerungswerte des nichtrostenden austenitischen Stahls 316. Mathew-M-D; Mannan-S-L; Rodriguez-P. Reactor res cent, Kalpakkam Tamilnadu 603102, IN. Zeitschriftenaufsatz: J. test. eval., Band 13 (1985) Heft 3, Seite 191- 195 (5 Seiten, 15 Quellen)	1985
30	Beitrag zur elektronischen Datenerfassung an Zugpruefmaschinen. Schwalbe-W; Voigtlaender-J. WTZ Technische Textilien (Dresden). Zeitschriftenaufsatz: Technische Textilien, Band 29 (1986) Heft 1, Seite 4ff (6 Seiten, 8 Bilder, 1 Tabelle)	1986
31	A study of the effect of tensile specimen form on the eccentricity of fracture. Einfluss der Probenform auf die Exzentrizitaet des Bruches im Zugversuch. Pretnar-B; Yebnah-R-A. Iskra Elementi, Sentjerney, YU; TOZD Radzvojni Inst, Novo Mesto, YU. Zeitschriftenaufsatz: Materialpruefung, Band 29 (1987) Heft 4, Seite 104-106 (3 Seiten, 3 Bilder, 2 Tabellen, 4 Quellen)	1987
32	Datenerfassung beim Zugversuch mit einem mobilen Laborrechnersystem (MINC) und nachfolgende rechnergestuetzte Auswertung. Data acquisition during tensile testing with a mobile laboratory computer (MINC) and subsequent computer aided evaluation. Distl-J-S. Max-Planck-Institut fuer Eisenforschung GmbH, Duesseldorf, DE, Abt fuer Umformtechnik. Zeitschriftenaufsatz: Materialpruefung, Band 29 (1987) Heft 4, Seite 95- 98 (4 Seiten, 6 Bilder, 4 Quellen)	1987
33	Mikrorechnergestuetzte Versuchsauswertung in der mechanischen Werkstoffpruefung. Micro computer aided evaluation of tests at the mechanical testing of materials. Toth-L; Romvari-P; Dehne-G. Technische Univ fuer Schwerindustrie, Miskole, HU; Technische Univ Otto von Guericke, Magdeburg, DD. Zeitschriftenaufsatz: Neue Huette, Band 32 (1987) Heft 12, Seite 444-445 (2 Seiten)	1987
34	Untersuchungen zum Elastizitaetsmodul von Staehlen bei hoeheren Temperaturen. Examinations on youngs modulus of steel at elevated temperatures. Maier-G. MPA Stuttgart, D. Zeitschriftenaufsatz: Materialpruefung, Band 29 (1987) Heft 11/12, Seite 358-366 (9 Seiten, 11 Bilder, 4 Tabellen, 26 Quellen)	1987

35	Tensile testing at constant true plastic strain rate / C.S. Hartley and D.A. Jenkins; Journal of metals (1987), pp 23	1987
36	Im Dialog. Steuern von Zugpruefmaschinen mit Personal-Computern in der Messtechnik. Peters-U. Zeitschriftenaufsatz: Der Maschinenmarkt, Band 94 (1988) Heft 39, Seite 84-88 (5 Seiten, 7 Bilder, 1 Tabelle)	1988
37	Optimierte Bestimmung des Elastizitaetsmoduls. Optimized determination of the modulus of elasticity. Urwank-P; Bergmann-U. Zeitschriftenaufsatz: Neue Huette, Band 33 (1988) Heft 3, Seite 93-94 (2 Seiten, 1 Bild, 4 Quellen)	1988
38	Probleme des Rechnergesteuerten Zugversuchs am Beispiel der Feinblechprüfung / Robiller, G ; Deutscher Verband fur Metallprufung e.V 1988 pp 69-77	1988
39	Auswirkungen des Laserschneidens von Flachzugproben auf die Ergebnisse des Zugversuches / Sonne, H.-M. - 1989 (Thyssen Technische Berichte) In: Thyssen Technische Berichte / Thyssen-Stahl-AG ; 21, 1989, Nr. 2, S. 191-196.	1989
40	Die Pruefmaschine als direkte Verformungsquelle. Ein neues Prinzip. The testing machine as a direct source of deformation. A new principle. Markowski-W. Bundesanstalt fuer Materialforschung und -pruefung, Berlin, DE. Konferenz-Einzelbericht: Werkstoffpruefung 1989, Bad Nauheim (DE), 07.- 08.12.1989, Deutscher Verband fuer Materialforschung und -pruefung (Berlin (DE)): Vortraege der Tagung Werkstoffpruefung 1989, (1989) Seite 365-376 (12 Seiten, 6 Bilder, 4 Quellen)	1989
41	Influence of machine type and strain rate interaction in tension testing / Gray, TGF ; Sharp, J ; ASTM 1989 STP 1025 pp187-205	1989
42	Mechanical testing - a basis for thermal process and material control: I Hardness. Mechanisches Pruefen - Basis der Waermebehandlungs- und Materialkontrolle: I. Haerte. Lasday-S-B. Zeitschriftenaufsatz: Industrial Heating, Band 56 (1989) Heft 3, Seite 22-25 (4 Seiten, 5 Bilder, 2 Tabellen, 1 Quelle)	1989
43	Mechanical testing - a basis for thermal process and materials control: II. tensile testing. Mechanische Testung - Basis fuer thermische Prozesssteuerung und Materialpruefung: II. Zugfestigkeit. Lasday-S-B. Zeitschriftenaufsatz: Industrial Heating, Band 56 (1989) Heft 5, Seite 24-26, 28 (4 Seiten, 12 Bilder)	1989
44	Probleme des rechnergesteuerten Zugversuchs. Dargestellt am Beispiel der Feinblechprüfung. Problems of the computer-controlled tensile test. Robiller-G. Thyssen Stahl, Duisburg, D. Zeitschriftenaufsatz: Materialpruefung, Band 31 (1989) Heft 11-12, Seite 371-376 (6 Seiten, 12 Bilder, 5 Quellen)	1989
45	Verfahren zur Bestimmung der Verformungsabhängigkeit des Verfestigungsexponenten und der senkrechten Anisotropie r / Sonne, H.-M.; Hesse, B.; Robiller, G. - 1989 (Thyssen Technische Berichte) In: Thyssen Technische Berichte / Thyssen-Stahl-AG ; 21, 1989, Nr. 2, S. 173-179.	1989

46	Factors that effect the precision of mechanical tests / R. Papirno and H.C. Weiss, eds., ASTM, Philadelphia (USA) 1989	1989
47	Verfahren zur Steigungsbestimmung der Hookeschen Geraden / Hesse, B.; Sonne, H.-M.; Robiller, G. - 1990 (Thyssen Technische Berichte) In: Thyssen Technische Berichte / Thyssen-Stahl-AG ; 22, 1990, Nr. 1, S. 115-122.	1990
48	Investigation to decrease the influence of measuring equipment and data processing on the results of automated tensile testing / Anon, Hoogovens EUR-Report 7210-GF/602 1990	1990
49	The Certification of Nimonic 75 Alloy as a Creep Reference Material, CRM 425".(1990). M S Loveday and D Gould. BCR Report EUR 13076	1990
50	Verfahren zur Neigungsbestimmung der Hookeschen Geraden (E-Modul) im rechnergesteuerten Zugversuch als Grundlage einer zuverlässigen Dehngrenzenermittlung / B. Hesse ; H.-M. Sonne ; G. Robiller. - 1990 (Werkstoffprüfung) In: Werkstoffprüfung / Gemeinschaftsveranstaltung von: DVM Deutscher Verband für Materialforschung und Prüfung ; DGM Deutsche Gesellschaft für Materialkunde ; VDEh Verein Deutscher Eisenhüttenleute ; 1990 Bad Nauheim, S. 149-160. SIG: QA 41(90)	1990
51	Investigation to decrease the influence of measuring equipment and data processing on the results of automated tensile testing. Untersuchung zur Verminderung des Einflusses der meß- und datenverarbeitenden Geräte auf automatische Zugversuche. Plas-D-W-v-d. Kommission der Europäischen Gemeinschaften, Luxembourg, L ; Hoogovens IJmuiden, IJmuiden, N. Report: Abschlußbericht der KEG, (1991) Seite 1-180 (180 Seiten, 75 Bilder, 41 Tabellen, 11 Quellen), Report-Nr. EUR 13 421	1991
52	Neigungsbestimmung der Hookeschen Geraden / Hesse, B.; Sonne, H.-M.; Robiller, G. – 1991 (Materialprüfung) In: Materialprüfung ; 33, 1991, Nr. 7/8, S. 208-211.	1991
53	Neuzeitliche Methoden einer anwendungsbezogenen Feinblechprüfung / W. Müschenborn ; G. Hartmann ; H.-M. Sonne. - 1991 (Werkstoffprüfung) In: Werkstoffprüfung / Gemeinschaftsveranstaltung von: DVM Deutscher Verband für Materialforschung und Prüfung ; DGM Deutsche Gesellschaft für Materialkunde ; VDEh Verein Deutscher Eisenhüttenleute ; 1991 Bad Nauheim, S. 243-271. SIG: QA 41(91)	1991
54	Influence of specimen dimension and grip in tensile testing steel to EN 10 002. Der Einfluß der Prüfkörperabmessungen und der Einspannvorrichtung bei der Zugprüfung von Stahl nach der Euronorm EN 10 002. Gray-T-G-F; McCombe-A. Strathclyde Univ, Glasgow, GB. Zeitschriftenaufsatz: Ironmaking and Steelmaking, Band 19 (1992) Heft 5, Seite 402-408 (7 Seiten, 12 Bilder, 3 Tabellen, 8 Quellen)	1992

55	In-situ determination of fiber strength and segment length in composites by means of acoustic emission. Vor-Ort-Bestimmung der Faserfestigkeit und der Fasersegmentlänge in Verbundwerkstoffen mit Hilfe der Schallemission. Manor-A; Clough-R-B. Nat Inst of Sci a Technol, Gaithersburg, USA. Zeitschriftenaufsatz: Composites Science and Technology, Band 45 (1992) Heft 1, Seite 73-81 (9 Seiten, 8 Bilder, 2 Tabellen, 14 Quellen)	1992
56	Research on Specimen Geometry Effects in Tensile Testing' (1992) T.Gray, Strathclyde University. Project MTD-SX 9/15. BSI Committee Document 92/48858	1992
57	Towards a tensile reference material".(1992). M S Loveday. Chapt 7. Harmonisation of Testing Practice for High Temperature Materials. Ed. M S Loveday and T B Gibbons. Pub. Elsevier Applied Science.	1992
58	The influence of the cross-section shape of specimens on strength characteristics under conditions of inhomogeneous flow / M. Fellner and E. Pink; scripta met. 27 (1992) S. 259	1992
59	Determination of Young's Modulus on steel sheet by computerised tensile test-Comparison of different evaluation concepts' (1993) . H.M.Sonne, and B.Hesse. Tagung Werkstoffprüfung. DVM – Tagungsband	1993
60	Neuzeitliche Methoden einer anwendungsbezogenen Feinblechprüfung / Müschenborn, W.; Sonne, H.-M.; Hartmann, G. - 1993 (Thyssen Technische Berichte) In: Thyssen Technische Berichte / Thyssen-Stahl-AG ; 25, 1993, Nr. 1, S. 121-135.	1993
61	Results of an Interlaboratory Test Programme on Room Temperature Tensile Properties- Standard Deviation of the Measured Values'. (1993) L.Roesch, N.Coue, J.Vitali and M.DI Fant . IRSID Report N. DT 93310	1993
62	Test machine and control system interactions in the evaluation of rate- dependent metal flow. Wechselwirkungen zwischen Zerreißmaschine und Meßsystem bei der Untersuchung geschwindigkeitsabhängiger Fließvorgänge von Metallen. Brown-S-B; Dave-V-R. Massachusetts Inst of Techn Cambridge, USA. Zeitschriftenaufsatz: Transactions of the ASME, Journal of Engineering Materials and Technology, Band 115 (1993) Heft 2, Seite 179-186 (8 Seiten, 18 Bilder, 20 Quellen)	1993
63	Zuverlässige Dehngrenzen im rechnergesteuerten Zugversuch ermitteln. Ein Verfahren zur Verfahrensvergleich zur E-Modul-Bestimmung im rechnergestützten Zugversuch / H.-M. Sonne ; B. Hesse. - 1993 (Werkstoffprüfung) In: Werkstoffprüfung / Gemeinschaftsveranstaltung von: DVM Deutscher Verband für Materialforschung und Prüfung ; DGM Deutsche Gesellschaft für Materialkunde ; VDEh Verein Deutscher Eisenhüttenleute ; 1993 Bad Nauheim, S. 63-72. SIG: QA 41(93)	1993
64	Determination of Young's modulus on steel sheet by computer-aided tensile test - comparison of different evaluation concepts / H.-M. Sonne ; B. Hesse. - 1994 (IDDRG Working Groups Meeting) In: IDDRG Working Groups Meeting / IDDRG ; Instituto Nacional de Engenharia e Tecnologia Industrial ; 1994 Lisbon, Beitr. WG 3. SIG: IC 31(94)	1994

65	Data Acquisition and Analysis of Tensile Properties for MMC' (1994) B.Roebuck, J.D.Iord, P.M.Cooper and L.N.McCartney, ASTM Journal of Testing & Evaluation (JTEVA) 22(1) 63-69.	1994
66	Probleme der normgerechten Durchführung des rechnergestützten Zugversuches / H.-M. Sonne (TST) ; A. Wehrstedt (DIN). - 1994 (Werkstoffprüfung) In: Werkstoffprüfung / Gemeinschaftsveranstaltung von: DVM Deutscher Verband für Materialforschung und Prüfung ; DGM Deutsche Gesellschaft für Materialkunde ; VDEh Verein Deutscher Eisenhüttenleute ; 1994 Bad Nauheim, S. 175-185. SIG: QA 41(94)	1994
67	Process control: tensile testing. Prozeßkontrolle: Zugfestigkeitsmessung. Schuette-K; Lobenhofer-R. Grede Foundries, Milwaukee, USA; Lobenhofer Consulting, Mt Prospect, USA. Zeitschriftenkurzaufsatz: Modern Casting, Band 84 (1994) Heft 1, Seite 42 (1 Seite)	1994
68	Round Robin Results of Interlaboratory Tensile Tests' (1994) ASTM Research Report RR E-28 1004.	1994
69	A Code of Practice for the Measurement of Misalignment Induced Bending in Uniaxially Loaded Tension-Compression Testpieces' (1995) J.Bressers, Euro Report EUR 16138 EN	1995
70	Aspects of Modulus Measurement".(1995). G Dean, M S Loveday, P M Cooper, B E Read and B Roebuck. Chapt 8, pp 150-209, Materials Metrology and Standards for Structural Performance. Ed. B F Dyson, M S Loveday and M G Gee. Pub. Chapman and Hall, London,	1995
71	Neue Entwicklungen in der mechanisch-technologischen Werkstoffprüfung. New developments in mechanical-technological materials testing. Dripke-M. Zeitschriftenaufsatz: Stahl, (1995) Heft 1, Seite 51-53 (3 Seiten)	1995
72	Rechnergestützter Zugversuch. Probleme der normgerechten Durchführung / Sonne, H.-M.; Wehrsted, A. (DIN). - 1995 (Materialprüfung) In: Materialprüfung ; 37, 1995, Nr. 4, S. 102-105.	1995
73	Standards for the Calibration of Extensometers". Appendix 5C to 'Strain-measurement by contact methods and extensometry'.(1995). M S Loveday. Chapt 5, 102-113 in Materials Metrology and Standards for Structural Performance. Ed. B F Dyson, M S Loveday and M G Gee. Pub. Chapman and Hall, London,	1995
74	Überlegungen zur Überprüfung von Zugprüfmaschinen mittels Referenzmaterial / H.-M. Sonne (TST) ; G. Knauf (MFI) ; J. Schmidt-Zinges (Stahlw. Bremen). - 1996 (Werkstoffprüfung) In: Werkstoffprüfung / Gemeinschaftsveranstaltung von: DVM Deutscher Verband für Materialforschung und Prüfung ; DGM Deutsche Gesellschaft für Materialkunde ; VDEh Verein Deutscher Eisenhüttenleute ; 1996 Bad Nauheim, S. 417-428. SIG: QA 41(96)	1996

75	Optische Dehngrenzen- und Bruchdehnungsbestimmung im Zugversuch / U. Thanscheidt ; J. Harder ; U. Paul ; H.-M. Sonne. - 1997 (Werkstoffprüfung) In: Werkstoffprüfung / Gemeinschaftsveranstaltung von: DVM Deutscher Verband für Materialforschung und Prüfung ; DGM Deutsche Gesellschaft für Materialkunde ; VDEh Verein Deutscher Eisenhüttenleute ; 1997 Bad Nauheim, S. 363-373. SIG: QA 41(97)	1997
76	Recommended Methods for Determining Young's Modulus from Tensile Tests' (1997). J.D.Lord and B. Roebuck . NPL Measurement Note CMMT(MN) 16	1997
77	Tensile Testing of Metal Proficiency Testing Program' 1997. APLAC T002 . Asia Pacific Accreditation Cooperation	1997
78	Dehngrenze und Bruchdehnung im Zugversuch optisch bestimmen / Ulrich Thanscheidt ; Jürgen Harder ; Udo Paul ; Hans- Martin Sonne. - 1998 (Materialprüfung) In: Materialprüfung ; 40, 1998, Nr. 9, S. 353-357.	1998
79	Elastic constants determination of thin cold-rolled stainless steels by dynamic elastic modulus measurements. Ableitung von elastischen Konstanten von dünn kaltewalztem rostfreien Stahl durch dynamische Messung des Elastizitätsmoduls. Lee-S-S; Min-U-S; Ahn-B; Yoo-S-H. Korea Res Inst of Standards and Sci, Taejan, Korea; Ajou Univ, Suwon, Korea. Zeitschriftenaufsatz: Journal of Materials Science, Band 33 (1998) Heft 3, Seite 687-692 (6 Seiten, 5 Bilder, 5 Tabellen, 18 Quellen)	1998
80	Elastoplastische Eigenschaften von Metallrohr. E-Modul- und Streckgrenzenbestimmung. Bauer-D; Khodayari-G; Schierz-M. Univ -GH Siegen, D. Zeitschriftenaufsatz: Bänder Bleche Rohre, Band 39 (1998) Heft 9, Seite 192,194-196,201 (5 Seiten, 5 Bilder, 1 Tabelle, 8 Quellen)	1998
81	Bestimmung des Elastizitätsmoduls im Zugversuch / H.-M. Sonne. - 1999 (Werkstoffprüfung) In: Werkstoffprüfung / Gemeinschaftsveranstaltung von: DVM Deutscher Verband für Materialforschung und Prüfung ; DGM Deutsche Gesellschaft für Materialkunde ; VDEh Verein Deutscher Eisenhüttenleute ; 1999 Bad Nauheim, S. 219-230. SIG: QD 41(99)	1999
82	Elevated Temperature Modulus Measurements for Discontinuously Reinforced Metal Matrix Composites' (1999). J.D.Lord and L.P.Orkney. NPL Measurement Note CMMT (MN) 038	1999
83	Elevated Temperature Modulus Measurements for Particulate Reinforced Metal Matrix Composites' (1999). J.D.Lord and L.P.Orkney. NPL Report CMMT(A) 156	1999
84	Neue Materialien und Anwendungen - Neue Anforderungen an die Materialprüfung. Spitzer-B. Zwick, Ulm, D. Buchkapitel: Taschenbuch für die Textilindustrie 2000, (1999) Seite 88-93 (6 Seiten, 7 Bilder), Berlin: Fachverlag Schiele & Schön	1999
85	Room Temperature Tensile Testing: A Method for Estimating Uncertainty of Measurement'.(1999) M.S.Loveday, NPL Measurement Note CMMT(MN) 048. July 1999. (Presented at the ISO Committee TC 164 SC1, Prague, June 1999)	1999

86	Abschätzung der Meßunsicherheit im Zugversuch. Assessment of measurement uncertainty in tensile test. Gabauer-W. Voest-Alpine Stahl Linz, A. Konferenz-Einzelbericht: Werkstoffprüfung 2000. Vortrags- und Diskussionsveranstaltung, Dt. Verband für Materialforschung und -prüfung e.V., Berlin, Bad Nauheim, D, 7.-8. Dez. 2000, (2000) Seite 139-144 (6 Seiten, 1 Bild, 4 Tabellen), Berlin: Dt. Verband für Materialforschung und -prüfung	2000
87	Den Elastizitätsmodul sicher bestimmen. Voraussetzung für die Kraft- und Dehnungsmessung im Zugversuch. Problems of reliable determination of Young modulus in mechanical materials testing. Leworuski-S; Eil-M; Kühn-H-J. Bundesanstalt f Materialforschung u -prüfung (BAM), Berlin, D. Zeitschriftenaufsatz: MP Materialprüfung, Band 42 (2000) Heft 4, Seite 109-113 (5 Seiten, 7 Bilder, 1 Tabelle, 6 Quellen)	2000
88	Einfluss der Prüfgeschwindigkeit auf die Streck-/Dehngrenze im Zugversuch nach DIN EN 10002-1 / J. Aegerter (VAW Aluminium) ; H. Bloching (Zwick) ; H.M. Sonne (TKS). - 2000 (Werkstoffprüfung) In: Werkstoffprüfung / Gemeinschaftsveranstaltung von: DVM Deutscher Verband für Materialforschung und Prüfung ; DGM Deutsche Gesellschaft für Materialkunde ; VDEh Verein Deutscher Eisenhüttenleute ; 2000 Bad Nauheim, S. 113-137. SIG: QA 41(00)	2000
89	Elevated Temperature Modulus Measurements Using the Impulse Excitation Technique (IET)'. (2000) J.D.Lord and L.P.Orkney . NPL Measurement Note CMMT (MN) 049	2000
90	Materialprüfung automatisieren - Zugversuch nach DIN EN 10 002-1. Löwe-M. Zeitschriftenaufsatz: Der Versuchs- und Forschungsingenieur, Band 33 (2000) Heft 2, Seite 27-30 (4 Seiten, 9 Bilder)	2000
91	Numerische Simulation zum Einfluß der Kenngrößen des Zugversuches im Umformprozeß / Jörg Gerlach ; Hans-Martin Sonne. - 2000 (Werkstoffprüfung) In: Werkstoffprüfung / Gemeinschaftsveranstaltung von: DVM Deutscher Verband für Materialforschung und Prüfung ; DGM Deutsche Gesellschaft für Materialkunde ; VDEh Verein Deutscher Eisenhüttenleute ; 2000 Bad Nauheim, S. 175-182. SIG: QA 41(00)	2000
92	The Certification of Tensile Properties of an Ambient Temperature Tensile Testing Reference Material According to EN 10002 - 1 : CRM 661" (2000) D. Ingelbrecht & M.S.Loveday. BCR Report EUR 19589 EN	2000
93	Toughness properties of hot- and cold-rolled multiphase steels / T. Heller ; C.P. Reip ; H.-M. Sonne ; T.W. Schaumann. – 2000 In: Werkstoffwoche 2000 ; München, 8 S. \fqpsrv03\le-doc\Materialsweek2000\Heller-Toughness.pdf SIG: Server/e-doc	2000
94	Automatisierte Metallprüfung. Bloching-H. Zwick, Ulm-Einsingen, D. Zeitschriftenaufsatz: Stahl, (2001) Heft 2, Seite 46-48 (3 Seiten, 4 Bilder)	2001

95	Certified reference materials for the validation of mechanical test methods' (2001). Malcolm S Loveday. pp37-48 in 'Investigation and Validation of Materials Testing Machines' Ed: Anne Satir & Walter Sennhauser. Pub : EMPA, [Presented at EUROLAB Workshop, EMPA, Dubendorf, Switzerland, 17/18th May 2001]	2001
96	Präzise, innovative und zuverlässige Prüfmaschinen. Kontrolle, Qualität und Maß. Zwick, Ulm-Einsingen, D. Zeitschriftenaufsatz: EuroWire, Band 4 (2001) Heft 1, Seite D12-D14 (3 Seiten, 3 Bilder)	2001
97	'Influence of the testing speed on the Yield / Proof Strength in compliance with EN 10002 –1.' (2001) J Aegerter, H Bloching, , and H-M Sonne, , MP Materialprüfung. 43 (10) 393 – 403.	2003

APPENDIX 2a. List of Papers relating to Tensile Testing compiled during NAS- TENSTAND Project a) Polish Papers

TENSTAND List of References & Relevant Literature		Year
	Poland	
1	Własności wytrzymałościowe oraz obróbka cieplna stali konstrukcyjnych chromowo – niklowych o odwróconym stosunku Cr do Ni / Biernacki, T; Bukowiecki, L; Hutnik, VIII, 10, 1936, 385-396 (Strength properties and heat treatment of Cr-Ni- steels with reversed relation between Cr and Ni)	1936
2	Własności wytrzymałościowe rur grubościennych w szczególności stali LA5 i LD5 Huty Baildon / Feszczenko-Czopiwski, I; Malkiewicz, T; Mazur, W; Hutnik, IX, 6, 1937, 261-293 (Strength properties of thick-walled pipes, in particular LA5 and LD5 steels in the Baildon Mill)	1937
3	Uzasadnienie zmiany norm wytrzymałościowych / Krupkowski, A; Hutnik, XII, 5, 1945, 185-190 (Justification of tensile strength norms)	1945
4	Wpływ zgniotu, temperatury i czasu wyżarzania na własności wytrzymałościowe i budowę stali walcowanych na zimno sposobem „Sędzimir” i wyżarzanych / Gockowski, St; Makowski H; Radwan, M; Hutnik, XIII, 1946, 14-25 (Effect of deformation, temperature and annealing time on structure of steels rolled in the Sendzimir mill)	1946
5	Uwagi o normie PN-62/H-04310 “Próba statyczna rozciągania metali” / Baranowski, B ; Hutnik, XXX, 12, 1963, 387-389. (Remarks on the standard PN-62/H-04310 “Static tensile test of metals”)	1963
6	Ustalania miejsca szyjki w próbie rozciągania / Jasiewicz, Z ; Gorczyca, S ; Ryś, J ; Hutnik, XXXI, 7-8, 1964, 258-264. (The locating of neck place in tensile test)	1964
7	Kryteria jakości drutów ze stali austenitycznej H18N10M do wyrobu sit tkanych / Godecki, L ; Hutnik, XXXIV, 2, 1967, 60-66 (Criteria of quality of austenitic H18N10M steel wire for the production of woven sieves - Tension test)	1967
8	<i>Badania statystycznej zależności pomiędzy stopniem przeróbki plastycznej na gorąco, a własnościami mechanicznymi stali 30HGS / Ryś, J ; Wolak, Z ; Hutnik, XXXV, 3, 1968, 103-109</i> (Examination of statistical relationship between the degree of hot working and mechanical properties of 30HGS steel. Tension test)	1968
9	Praktyczne wyznaczanie wydłużenia równomiernego próbek blach w prostej próbie rozciągania / Turno, A ; Obróbka Plastyczna, IX, 2, 1970,	

	243-269. (Practical assessment of the uniform elongation of sheet-metal specimens in standard tension test)	1970
10	Zakresy odkształcania w próbie rozciągania polikrystalicznej miedzi / Styczyński, A ; Jasieński Z ; Rudy i Metale Nieżelazne, 15, 6, 1970, 309-314 (Deformation ranges in polycrystalline copper tensile tests)	1970
11	<i>Wskaźniki mechanicznych własności stali 1H13 i 1H18N10T przy temperaturach podwyższonych jako kryterium do oceny odkształcania plastycznego / Schneider, M ; Madej, J ; Sadok, L ; Hutnik, XXXVII, 5, 1970, 238-242.</i> (Indexes of mechanical properties of 1H13 and 1H18N10T steels at elevated temperatures as criteria for evaluation of plastic deformation - Tensile test at 700-1250 °C on 4-t ZD-4 machine)	1970
12	Rola wskaźnika kształtu próbki wytrzymałościowej w statycznej próbie rozciągania / Misiołek, Z ; Prace Instytutów Hutniczych, 4, 1970, 179-196 (The role of the test-pieces shape factor in the tensile tests)	1970
13	Porównanie dokładności pomiarów granicy plastyczności przy podwyższonych temperaturach / Kozłowski, R; Wiadomości Hutnicze, XXVI ,11, 1970, 245-248 (Comparison of accuracy of yield point measurement at high temperatures)	1970
14	Analiza własności mechanicznych wyrobów z metali nieżelaznych / Misiołek, Z; Rudy i Metale Nieżelazne, 16, 1, 1971, 31-35 (Analysis of the mechanical properties of non-ferrous metal products - Excellent source of data, and review on tensile testing, new testing procedures and certification marks)	1971
15	Wpływ temperatury i szybkości odkształcania na własności mechaniczne i plastyczne miękkiej stali / Milczarek, E ; Obróbka Plastyczna, X, 1971, 201-216. (Effect of temperature and deformation rate on mechanical and plastic properties of low carbon steel)	1971
16	<i>Optymalizacja obróbki cieplnej i badania własności mechanicznych przy podwyższonych temperaturach stali ferrytyczno – perlitycznych na rury energetyczne / Eysymontt, J ; Hutnik, XXXVIII, 2, 1971, 83-90</i> <i>Optimalization of heat treatment and examination of mechanical properties at elevated temperatures of ferritic – perlitic steels for pipes to be used in power industry</i>	1971
17	<i>Mikrostrukturalne zjawiska w strefie szyjki rozciąganej próbki stalowej / Rudnik, S ; Wielgosz, R ; Hutnik, XXXVIII, 5, 1971, 259-262</i> (Phenomena of microstructural character in the necking of a tensile test piece during tension tests)	1971
18	<i>Wpływ zawartości węgla w stali na rozrzut wyników badania</i>	

	wytrzymałości na rozciąganie / Ryś, J ; Śpiewak, W ; Wolak, Z ; Hutnik, XXXVIII, 9, 1971, 432-437. (The effect of a carbon content in steel on the scatter of results of tensile strength tests.	1971
19	Czułość żelaza Armco na prędkość odkształcenia wywołana starzeniem dynamicznym / Milczarek, E ; Obróbka Plastyczna, XI, 3, 1972, 149-159. (Strain rate sensitivity of Armco iron as caused by strain ageing – Tensile curves and tensile tests)	1972
20	Propozycja prób zrywania z prędkością odkształcenia rzędu $10^2\text{s}^{-1} \leq \dot{\epsilon} \leq 10^4\text{s}^{-1}$ / Kotkowski, K ; Obróbka Plastyczna, XI, 2, 1972, 75-80 (Suggestion of a tensile test with deformation velocities in the range $10^2\text{s}^{-1} \leq \dot{\epsilon} \leq 10^4\text{s}^{-1}$)	1972
21	Odkształcalność stali 18G2A, 18G2ACu i 18G2VA / Grosman, F ; Godecki, L; Wiadomości Hutnicze, XXVIII, 7-8, 1972, 242-248 (Deformability of 18G2A, 18G2ACu and 18G2VA steels)	1972
22	Badania statystyczne własności wytrzymałościowych taśm i rur ze stali 10BX / Waclawski, A ; Wiadomości Hutnicze, XXIX, 5, 1973, 157-161 (Statistical investigations of mechanical properties of 10BX steel strip and pipes – Results obtained from tensile tests)	1973
23	Charakterystyki wytrzymałościowe stali WNL i WCL / Berkowski, L ; Wroczyński, K ; Koniecznyński, M ; Obróbka Plastyczna, XII, 1973, 155-167. (Tensile characteristics of WNL and WCL tool steels - Tests on INSTRON TT-DM-L machine)	1973
24	Przyczyny i wpływ błędów pomiarowych przy pomiarze sił i odkształceń / H. Dripke, Hutnik, XL, 1, 1973, 36-40. (The causes and the effect of the measuring errors in measuring the forces and deformations.)	1973
25	Własności stali WNL i WCL w statycznej próbie rozciągania na gorąco. / Berkowski, L ; Koniecznyński, M ; Wroczyński, K ; Obróbka Plastyczna, XIII, 2, 1974, 73-80. (Mechanical properties of the WNL and WCL hot work tool steels in statical tension at elevated temperatures)	1974
26	Pole temperatur powierzchni próbki statycznie rozciąganej / Mazurkiewicz, J. Budak, J ; Obróbka Plastyczna, XIV, 4, 1975, 219-224 (Temperature field on the surface of a statically deformed tensile test piece)	1975
27	Własności stali WWS1, WLK i WWN1 w statycznej próbie rozciągania na gorąco / Berkowski, L ; Koniecznyński, M ; Wroczyński, K ; Obróbka Plastyczna, XIV, 3, 1975, 133-144 (Properties of three hot work tool steels in the high temperature tensile test)	1975
28	O krzywych umocnienia. / Pełczyński, T ; Obróbka Plastyczna, XIV, 1, 1975, 5-34 (On the stress – strain curves)	1975

29	<i>Wpływ wielkości ziarna na charakter przelomu po rozciąganiu stali 0H17T / Wieczorek, A ; Gorczyca, S ; Hutnik, XLII, 6, 1975, 258-262</i> <i>The influence of the grain size on the character of fracture after the extension of 0H17T steel.</i>	1975
30	Odkształcenie graniczne metali / Misiólek, Z ; Kastner, P; Rudy i Metale Nieżelazne, 21, 11, 1976, 435-439 (Metal deformation limits, tension tests)	1976
31	Możliwości elektronicznych maszyn wytrzymałościowych / Polek, Z ; Zagierski, P ; Wiadomości Hutnicze, XXXII, 3, 1976, 107-110 (Possibilities of electronic mechanical testing machine)	1976
32	Badanie umocnienia gruboziarnistego mosiądzu / Grabianowski, A ; Kloch J ; Rudy i Metale Nieżelazne, 22, 5, 1977, 221-227 (Investigations into strain hardening of coarse grain brass, original technique of tension test)	1977
33	Szybka ocena wytrzymałości materiałów / Balicki, S; Wiadomości Hutnicze, XXXIII, 6, 1977, 205-210 (A rapid method for evaluation of strength of materials)	1977
34	Własności mechaniczne mosiądzu α / Gryziecki, J ; Dybiec, H ; Rudy i Metale Nieżelazne, 23, 10, 1978, 501-507 (Mechanical properties of α brass – tension tests at 77 – 723K)	1978
35	Zagadnienie oszczędności materiału w próbach wytrzymałościowych. Cz.I Racjonalna wielkość próbek / Krupkowski, A ; Dańda, A ; Rudy i Metale Nieżelazne, 23, 8, 1978, 378-381 (The problem of material saving in strength tests. Rational sample quantity)	1978
36	Nowa definicja umownej granicy plastyczności i metody jej wyznaczania / Grzymkowski, M ; Obróbka Plastyczna, XVIII, 2, 1979, 69-72. (Proposal of a new definition of the proof stress in the tensile test and a method for its measurement)	1979
37	Analiza tensorów naprężenia i odkształcenia na przykładzie jednoosiowego rozciągania / Grzymkowski, M ; Obróbka Plastyczna, XIX, 4, 1980, 177-181. (Analysis of the stress and strain tensors in the case of uniaxial tension)	1980
38	Wpływ skokowej zmiany prędkości odkształcenia na zmianę naprężenia uplastyczniającego w próbie jednoosiowego rozciągania żelaza Armco / Milczarek, E ; Obróbka Plastyczna, XIX, 3, 1980, 167-171 (The effect of a stepwise change of the deformation velocity on the variations of the flow stress of Armco iron in uniaxial tension)	1980
39	Wpływ przerwy w próbie jednoosiowego rozciągania na zmianę naprężenia uplastyczniającego żelaza Armco / Milczarek, E ; Obróbka Plastyczna, XIX, 2, 1980, 107-112. (Influence of interruptions during the uni-axial tensile test on the flow stress of Armco iron)	1980
40	Efekt Bauschingera i własności mechaniczne wyrobów kształtowanych plastycznie na zimno / Bouhelier, C ; Chabenat, A ; Lecroisey, F ;	

	Obróbka Plastyczna, XIX, 2, 1980, 91-105. (The Bauschinger effect and the mechanical properties of cold formed components)	1980
41	Badania nad skłonnością do relaksacji naprężeń żelaza Armco w próbie jednoosiowego rozciągania / Milczarek, E ; Obróbka Plastyczna, XX, 1, 1981, 25-29 (Investigation upon the susceptibility to the stress relaxation of the Armco iron in uniaxial tension)	1981
42	Czułość na prędkość odkształcenia cynku w temperaturze otoczenia / Piela, K ; Rudy i Metale Nieżelazne, 27, 8, 1982, 361-364 (Sensitivity of zinc to the strain rate at ambient temperature - Tension tests)	1982
43	Wytrzymałość na rozciąganie, a trwałość zmęczeniowa stali 23GHNMA / Wolak, Z; Wiadomości Hutnicze, XXXIX, 6, 1983, 195-198 (Tensile strength and fatigue life of the 23GHMA steel)	1983
44	Dynamiczne starzenie odkształceniowe żelaza i stali w warunkach rozciągania/ Gliwa, M; Wiadomości Hutnicze, XL, 11-12, 1984, 320-326 (Dynamic strain – ageing of iron and steel under stretching conditions – Review of the literature)	1984
45	Umocnienie monokryształów cynku z dodatkami aluminium i miedzi / Łatkowski, A ; Wesołowski, J ; Rudy i Metale Nieżelazne, 29, 10, 1984, 435-438 (Consolidation of zinc mono-crystals with additions of aluminium and copper, static tensile test)	1984
46	Wytrzymałość na zmęczenie, a wytrzymałość na rozciąganie w obrabianej cieplnie stali na łańcuchy górnicze / Wolak, Z; Paczuła, B; Wiadomości Hutnicze, XLI, 5, 1985, 155-158 (Fatigue strength and the tensile strength of the heat treated steel for mining chains)	1985
47	Własności mechaniczne mosiądźców CuZn40 i CuZn40Pb2 w temperaturach podwyższonych / Salski, M ; Rudy i Metale Nieżelazne, 31, 8, 1986, 280-284 (Mechanical properties of CuZn40 and CuZn40Pb2 brasses at elevated temperatures, figure of tensile test sample fixing)	1986
48	Własności wytrzymałościowe blach grubych ze stali 15GAJ / Goczał, J; Wiadomości Hutnicze, XLIII, 9, 1987, 225-229 (Mechanical properties of plates made of 15GAJ steel)	1987
49	Charakterystyczne cechy krzywych rozciągania stopów dwufazowych / Frydman, S ; Rudy i Metale Nieżelazne, 33, 2, 1988, 55-57 (Characteristic of tension curves of two-phase alloys)	1988
50	Własności blach cynkowych / Mikułowski, B ; Piela, K ; Śliwa, A ; Rudy i Metale Nieżelazne, 33, 10, 1988, 374-376 (Properties of sheet zinc, standard tension test)	1988
51	Wytrzymałość stali na zmęczenie, a wytrzymałość na rozciąganie / Wolak, Z; Paczuła, B; Wach, A; Wiadomości Hutnicze, XLIV, 7-8, 1988,	

	192-195 (Fatigue strength and tensile strength of steel)	1988
52	Metoda oceny stali szybkoobrotowych jako materiałów przeznaczonych na narzędzia do obróbki plastycznej na zimno / Berkowski, L ; Obróbka Plastyczna Metali, XVIII, 2, 1989, 13-21 (A method to evaluate high speed steels as materials for cold working tools).	1989
53	Umocnienie w procesie ciągnięcia drutów z brązu B6 / Dybiec, H ; Skubiela, M ; Rudy i Metale Nieżelazne, 34, 9, 1989, 308-311 (Hardening in the process of wire drawing of bronze B6, standard tension test)	1989
54	Możliwości określenia parametrów zmęzeniowych stali z próby rozciągania / Cesarz, St ; Kučera, J ; Kufa, T ; Prace Instytutu Metalurgii Żelaza, 1-2, 1989, 32-46 (Possibilities of evaluation of fatigue parameters of steel by means of tensile test)	1989
55	<i>Własności mechaniczne brązu aluminiowego BA93 w niskich temperaturach / Frydman, S; Grzegorzewicz, T; Rudy i Metale Nieżelazne, 36, 3, 1991, 84-86.</i> (<i>Mechanical properties of aluminium bronze BA93 in low temperatures</i>)	1991
56	<i>Własności mechaniczne brązu aluminiowego CuAl8CrZr w niskich temperaturach / Grzegorzewicz, t ; Frydman, S ; Wojciechowski, B ; Rudy i Metale Nieżelazne, 36, 5, 1991, 174-177.</i> <i>Mechanical properties of aluminium bronze CuAl8CrZr in low temperatures.</i>	1991
57	<i>Własności mechaniczne stali 0H21AN10M3Nb w stanie po plastycznej przeróbce na gorąco / Kaliszewski, E ; Pisarek, I ; Hutnik - Wiadomości Hutnicze, 1994, LXI, 12, 371-377.</i> <i>Mechanical properties of 0H21AN10M3Nb steel after hot working</i>	1994
58	<i>Ocena własności plastycznych taśm z mosiądzu CuZn30 walcowanych po odlewaniu ciągłym / Borko, H ; Stachowicz, F ; Rudy i Metale Nieżelazne, 40, 11, 1995, 456-460.</i> <i>Evaluation of plastic properties of brass CuZn30 strips, rolled after continuous casting.</i>	1995
59	<i>Własności mechaniczne szyn kolejowych walcowanych w Hucie Katowice S.A. ze wsadu COS / Bartyzel, J ; Hajka, j ; Sroka, S ; Cesarz, S ; Hernas A, Hutnik - Wiadomości Hutnicze, 1997, LXIV, 7, 304-307.</i> <i>Mechanical properties of railway rails rolled at Katowice Steelworks S.A. from continuous casings.</i> <i>Statistical analysis of acceptance results, tensile tests in accordance with EN standard for rails were carried out respecting the years 1995 and 1996</i>	1997
60	<i>Kwantyfikacja własności mechanicznych wyrobów i półwyrobów stalowych / Kasprzyk, A ; Hutnik - Wiadomości Hutnicze, LXV, 11, 1998, 435-438</i>	

	<i>Quantification of mechanical properties of finished and semi-finished steel. Author's suggestion to take advantage of quantification principles for ordering notions connected with mechanical properties (tensile test) is presented.</i>	1998
61	Wpływ stopnia zgniotu blachy na wybrane parametry tłoczenia / Chałupczak, J; Miłek, T ; Obróbka Plastyczna Metali, 10, 3, 1999, 5-10 (Influence of cold work ratio on selected parameters in deep drawing)	1999
62	Badania własności wytrzymałościowych szkła organicznego osłon kabin samolotowych i statystyczna ocena wyników / Kłysz, S; Przegląd Mechaniczny, 59, 17-18, 2000, 19-22 (Examining strength properties of organic glass for aircraft cockpit canopies and statistic assessment of the results – Static tensile tests)	2000
63	Azotowanie stali konstrukcyjnych obrobionych plastycznie. Część I: Materiał badań i opis stosowanych metod obróbki plastycznej / Berkowski, L ; Obróbka Plastyczna Metali, 12, 3, 2001, 5-13. (Nitriding of constructional steel after cold deformation. Part I: Experimental material and description of the method of deformation)	2001
64	Model materiału do analizy procesów kształtowania blach / Gronostajski, Z ; Weiler, W ; Obróbka Plastyczna Metali, 12, 3, 2001, 35-39. (The constitutive equation for analysis of metal forming processes)	2001
65	Wpływ technologii kształtowania obróbka plastyczną na zimno na strukturę i własności mechaniczne śrub ze stali ferrytyczno- martenzytycznej / Bear, J ; Borowski, J ; Samolczyk, J ; Jóźwiak, K ; Obróbka Plastyczna Metali, 12, 2, 2001, 19-26 (Influence of cold working forming on the structure and mechanical properties of bolts made of dual-phase steel)	2001
66	<i>Własności mechaniczne stali mikroskopowej Bw08GNbA przeznaczonej na tuleje wysokociśnieniowe / Lisiecki, J ; Kłysz, S ; Hutnik - Wiadomości Hutnicze, LXIX, 3, 2002, 80-83. (Mechanical properties of micro-alloyed Bw08GNbA steel for high- pressure sleeves)</i>	2002
67	<i>Termodynamiczna analiza pojęcia zdolności magazynowania energii w procesie jednoosiowego rozciągania polikryształu / Oliferuk W., Raniecki B., Archives of Metallurgy, 47, 2002, 262-273. (Thermodynamic analysis of energy storage rate during uni-axial tensile deformation of polycrystalline metal)</i>	2002

ABSTRACTS OF THE SELECTED MOST IMPORTANT POLISH PAPERS:

1. Uwagi o normie PN-62/H-04310 "Próba statyczna rozciągania metali"

Remarks on the standard PN-62/H-04310 "Static tensile test of metals"

B. Baranowski: Hutnik, XXX, 12, 1963, 387-389.

Abstract: The general characteristic of the norm is presented in the paper. It is emphasized that the norm should follow the progress in methods of testing of materials. The following aspects of the norm are discussed: definition of the flow stress, the yield stress and the tensile strength, measurement of elongation, tensometer, sample geometry. Author discusses all these aspects and gives the suggestions of changes, which should be introduced in order to make the norm more precise.

Key words: Material: general; Samples: cylindrical, flat; Specimen geometry; Rate control: extensometer, Low temperature

2. Praktyczne wyznaczanie wydłużenia równomiernego próbek blach w prostej próbie rozciągania

Practical assessment of the uniform elongation of sheet-metal specimens in standard tension test

A. Turno, Obróbka Plastyczna, IX, 2, 1970, 243-269.

Abstract: The uniform elongation is an important characteristic of material deformability. The paper deals with the problem of determination of the zone of uniform deformation in the conventional tensile tests. Authors refer to the Polish and Russian norms, which define the uniform elongation. Then they investigate an influence of inhomogeneity of the sample on the zone of uniform elongation. The following parameters are investigated: variations of dimensions within the range allowed by the norms, strain rate sensitivity, inhomogeneity of microstructure, texture, dislocation density and defects. Various criteria of determination of the uniform elongation zone are compared for both cylindrical and flat samples. Various types of samples are investigated, including SOLLAC two stage samples. The general conclusion of the work is the method of interpretation of tensile test graphs. This method allows to obtain more consistent results from different tests. Finally, the definition of strain and elongation inhomogeneity is proposed in the paper.

Key words: Material: Steel, Aluminium; Samples: cylindrical, flat; Specimen geometry; Strain rate sensitivity; Uncertainty: error; Low temperature

3. Porównanie dokładności pomiarów granicy plastyczności przy podwyższonych temperaturach

Comparison of accuracy of yield point measurement at elevated temperatures

R. Kozłowski, Wiadomości Hutnicze, XXVI, 11, 1970, 245-248

Abstract: The objective of the work is comparison of results of tensile tests performed at various laboratories. The testing machines were compared first. Three parameters of the machines were investigated: accuracy of measurement

of loads, accuracy of measurements of elongation, accuracy of temperature control. The conclusions compose evaluation of precision of various machines.

Key words: Material: Steel; Samples: cylindrical; Rate control: extensometer; Round robin; Measuring systems; High temperature, Low temperature

4. Mikrostrukturalne zjawiska w strefie szyjki rozciąganej próbki stalowej

Phenomena of microstructural character in the necking of a tensile test piece during tension tests

S. Rudnik, R. Wielgosz; *Hutnik*, 38, 5, 1971, 259-262

Abstract: *The discontinuities formed in the deformed metal. The character of discontinuities in the necking of a tensile test piece during tension. The methods employed in investigating the discontinuities.*

Key words: Material: Armco iron; Samples: cylindrical

5. Propozycja prób zrywania z prędkością odkształcenia rzędu $10^2\text{s}^{-1} \leq \dot{\epsilon} \leq 10^4\text{s}^{-1}$

Suggestion of a tensile test with deformation velocities in the range $10^2\text{s}^{-1} \leq \dot{\epsilon} \leq 10^4\text{s}^{-1}$

K. Kotkowski, *Obróbka Plastyczna*, XI, 2, 1972, 75-80

Abstract:

The scheme of an apparatus to perform dynamic tensile tests is presented. The tensile pulse is generated by the underwater discharge method. A mathematical analysis of the tensile test mechanism is given. For stress measurement in dynamic conditions a quasistatic method is proposed and the suitability of resistance strain gages to record short impulse processes is considered. Strains may be measured by the photometric method, by means of a non-inert light flux. The measuring possibilities and accuracy of the suggested electric converter system are discussed. The application of a two-channel cathode ray oscilloscope allows to record in time stresses and strain, as well as, directly, the tensile diagram and to determine the mean deformation velocity.

Key words: Material: General; Measuring systems

6. Pole temperatur powierzchni próbki statycznie rozciąganej

Temperature field on the surface of a statically deformed tensile test piece

J. Mazurkiewicz, J. Budak, *Obróbka Plastyczna*, XIV, 4, 1975, 219-224

Abstract: The strain nonuniformity cause nonuniform temperature rise in the strained test piece. The temperature fields are determined by means of a thermo vision apparatus. The necking locus may be determined by this method before the maximum tensile load is reached. The local temperature rise in the statically strained test piece exceeds 30°C. The temperature nonuniformity advances during necking.

Key words: Material: steel, Samples: flat; Measuring system; Specimen geometry; Uncertainly: scatter; Low temperature

7. Nowa definicja umownej granicy plastyczności i metody jej wyznaczania

Proposal of a new definition of the proof stress in the tensile test and a method for its measurement

M. Grzymkowski; *Obróbka Plastyczna*, XVIII, 2, 1979, 69-72

Abstract: A new method to determine the proof stress at the point of the greatest curvature of the experimental stress-strain curve is proposed. The association of the proof stress with the point of the greatest curvature seems to have a physical justification. This point may be determined graphically or analytically through the approximation of the stress-strain curve by means of a second order polynomial. Three other methods for the evaluation of the proof stress now in use are mentioned: the method of conventional proof stress preferred by the engineers, the method of the tangent and the method of the secant.

Key words: Material: Metals, alloys; New method to determine the proof stress

8. Czulość na prędkość odkształcenia cynku w temperaturze otoczenia

Strain rate sensitivity of zinc at room temperature

K. Pięła; *Rudy i Metale Nieżelazne*, 27, 8, 1982, 361-364

Abstract: The objective of the work is investigation of strain rate sensitivity of materials' flow stress. Tensile tests are used in the investigation. The test were performed for various constant strain rates and for strain rates varying during the test. The tested material was zinc. The results of the analysis were correlated with the microstructure evolution. It was concluded that relationship $\ln(\sigma) - \ln(\dot{\epsilon})$ is divided into two linear parts. Division is connected with the beginning of the process of twinning. Appearance of twins results with an increase of strain rate sensitivity.

Key words: Material: zinc, Samples: cylindrical, Strain rate sensitivity,

9. Charakterystyczne cechy krzywych rozciągania stopów dwufazowych

Characteristic of tension curves of two-phase alloys

S. Frydman, *Rudy i Metale Nieżelazne*, 33, 2, 1988, 55-57

Abstract: Two phase brass was investigated. The material contained approximately equal volume fractions of plastic phase β and rigid phase γ . Analysis of tensile test results for various grain size of the material and for various temperatures was performed. It was observed that two types of stress-strain curves are possible. The curves can have one or two breaking points. It is shown in the paper that the type of the curve depends on relative relation between yield stress of the plastic phase and the decohesion stress of the rigid phase.

Key words: Material: Brass; Samples: cylindrical; Specimen geometry; Strain rate sensitivity; Uncertainty: error; High temperature

10. Możliwości określenia parametrów zmęczeniowych stali z próby rozciągania **Possibilities of evaluation of fatigue parameters of steel by means of tensile test**

S. Cesarz, J. Kucera, T. Kufa, *Prace IMŻ*, 1989, 1-2, 32-46

Abstract: Results of low-cycle fatigue tests obtained in VUHZ – Dobra and IMZ – Gliwice and literature data for a number of steels manufactured in USSR, USA

and JAPAN (185 heats in all) were used in an attempt to establish a correlation between the more easily obtainable tensile strength data and parameters of low-cycle fatigue. In logarithmic coordinates a linear relation was obtained between tensile strength and the parameters of low-cycle fatigue. The data were also used for evaluation of relation between fatigue strength and threshold plastic strain on one side and tensile strength on the other. The results make it possible to predict low-cycle fatigue parameters at constant strain amplitude for steels in which for various reasons the precise value are not known but needed for safe and economical design.

Key words: Material: Steel; Uncertainly: scatter, error; Round robin experiment

11. Rola wskaźnika kształtu próbki wytrzymałościowej w statycznej próbie rozciągania

The role of the test-pieces shape factor in the tensile tests

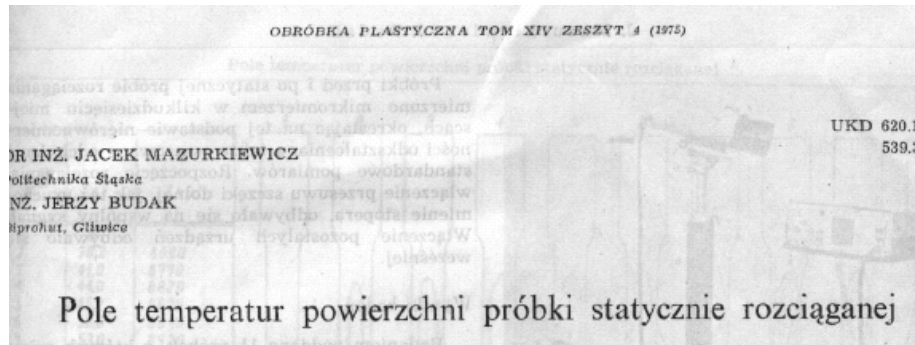
Z. Misiólek, Prace Instytutów Hutniczych, 4, 1970, 179-196

Abstract: *A survey is made of published comments on the effect of the geometry of rectangular section test-piece on mechanical properties as revealed by the tensile tests. The shape and dimensions of test-pieces are described, and the way of procedure and the results of tensile tests which were carried out with a series of fivefold test-pieces for test-pieces for aluminium Al, brass M63 and low-carbon 15Y steel, are discussed. A statistical evaluation of the influence of the test-piece shape factor on the strength and plastic properties – represented by the width to thickness ratio in the gauge length portion – is described. The investigations have shown that the tensile strength is not dependent on the shape factor of the test-pieces, on the other hand they have also proved that the shape factor has an inversely proportional effect on the elongation and the reduction in area. Respective functional relationships, and correction coefficients for elongation and the reduction in area have been established, thus permitting to determine rectangular section test-pieces of arbitrary shape factor their representative values for the metal and the test-pieces non affected by the shape. The determined dependency of elongation on the width, at a constant thickness, was confirmed by an analysis of stress distribution and the deformation in the gauge length portion of the test-pieces. It was also experimentally established, and than confirmed by a mathematical analysis that the deformation of test-pieces during the tensile strains takes place mainly at the expense of their width primarily in the zone of the elongation in the neck.*

Key words: Material: aluminum, brass, low-carbon steel; Specimen form, specimen geometry: parallel/gauge length ratio, width/thickness.

EXTRACTS form Selected POLISH Papers

Pole temperatur powierzchni próbki statycznie rozciąganej / Mazurkiewicz J., Budak J ; Obróbka Plastyczna, XIV, 4, 1975, 219-224 (**Temperature field on the surface of a statically deformed tensile test piece**)



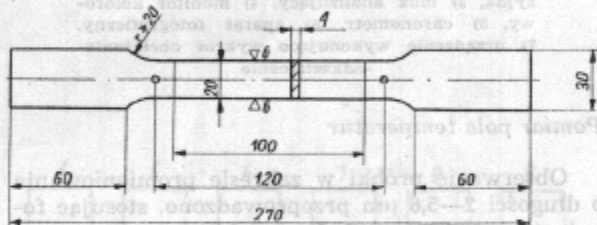
Abstract

The strain nonuniformity cause nonuniform temperature rise in the strained test piece. The temperature fields are determined by means of a thermovision apparatus. The necking locus may be determined by this

method before the maximum tensile load is reached. The local temperature rise in the statically strained test piece exceeds 30°C. The temperature nonuniformity advances during necking.

Do badań użyto próbek płaskich, statycznie rozciąganych. Próbkę rozciągania przyjęto z powodu możliwości wyeliminowania efektów cieplnych, wynikłych z pracy tarcia sił zewnętrznych. Ponadto próbka płaska, stosowana w badaniach (rys. 1), ze względu na duże powierzchnie płaskie, zapewnia lepsze warunki pomiaru temperatur aniżeli próbka okrągła.

Statyczną próbę rozciągania wykonano używając maszyny wytrzymałościowej ZWICK 1480. Podczas rozciągania próbki obserwowano jej powierz-



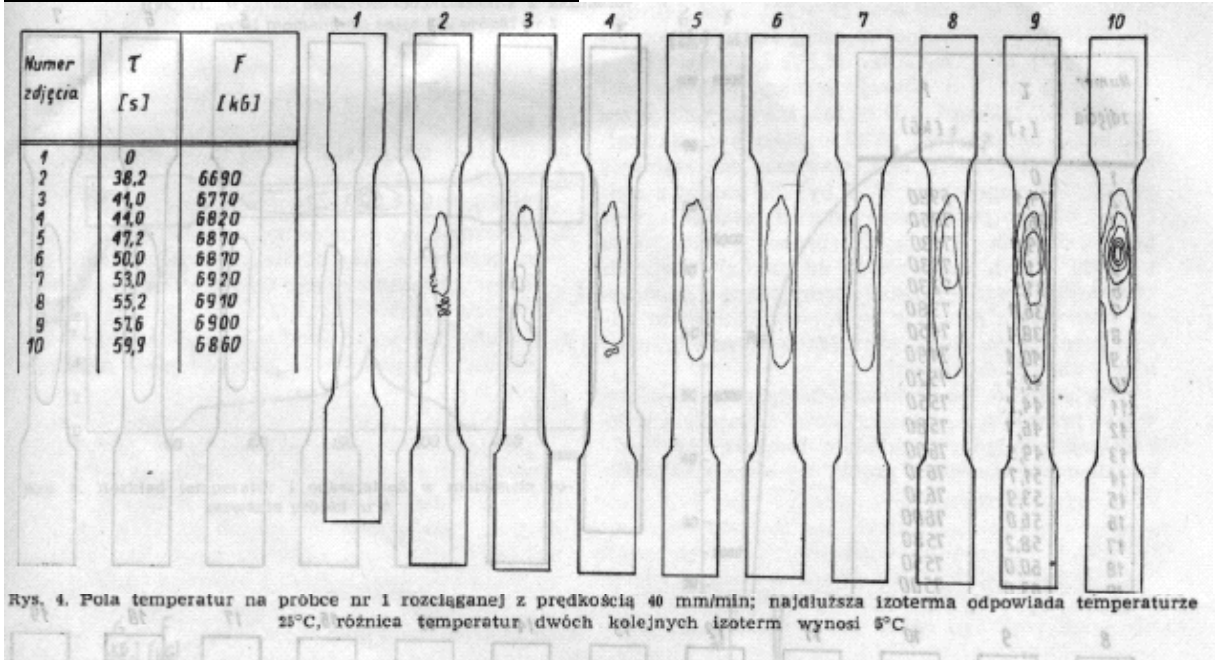
Rys. 1. Próbkę stosowana w badaniach. Stal 08H17N18M8

chnie w zakresie promieniowania podczerwonego. Obserwacji tej dokonywano za pomocą urządzenia termowizyjnego AGA Thermovision 680.

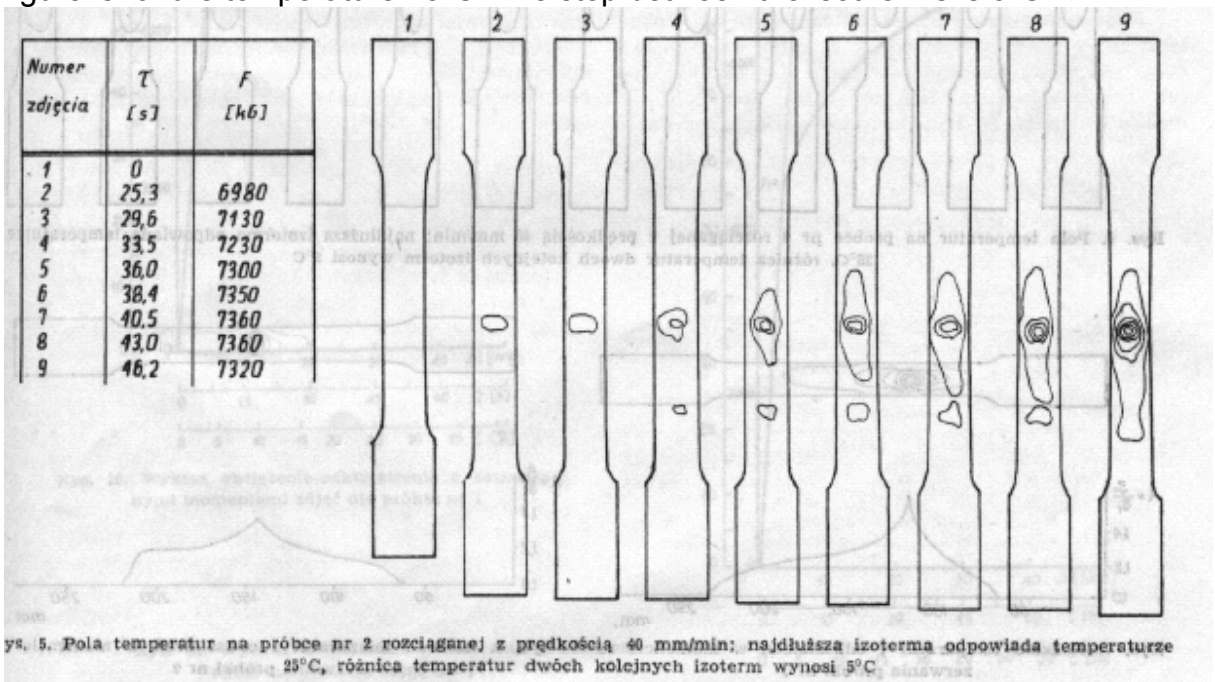
W skład urządzenia (rys. 2) weszły: kamera telewizyjna, blok analizujący z kontrolnym monitorem czarno-białym i monitor kolorowy, zapewniający o wiele większą czytelność obrazu. Obok monitora kolorowego umieszczono chronometr (stoper) służący do późniejszego ustalania kolejności zjawisk. Wykonywane zdjęcia obrazów z monitora, łącznie ze stoperem, pozwoliły przyporządkować każdemu rozkładowi temperatur określony punkt na wykresie otrzymanym z maszyny wytrzymałościowej. Rozciąganie przeprowadzono ze stałą prędkością przesuwu uchwytu maszyny, wynoszącą 40 mm/min.

Flat samples were used in the tests (Fig. 1). The samples had large flat surfaces, which enabled easy measurement of the temperature. All the tests were performed on the ZWICK 1480 machine. Temperatures were monitored by measurement of the infrared radiation.

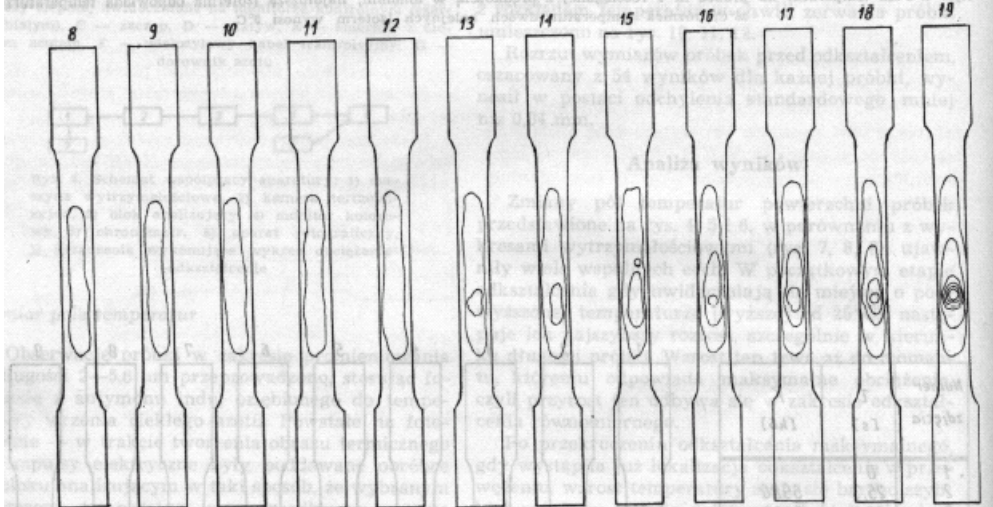
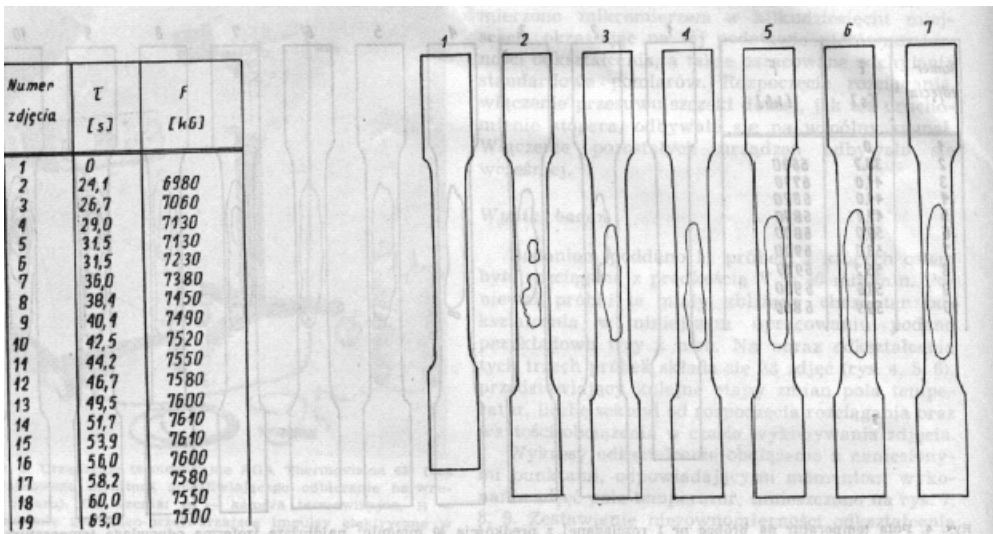
Temperature fields – selected results:



Temperature fields in the sample 1 at various stages of the test. Tool velocity 40 mm/min. Time (τ) and load F are given in the table. The longest isotherm in each figure is for the temperature 25°C. The step between the isotherms is 5°C.

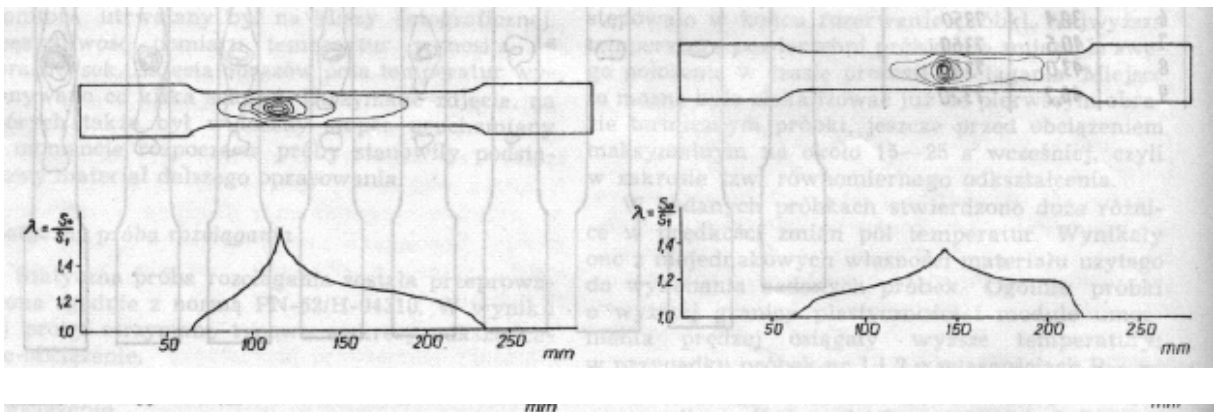


Temperature fields in the sample 2 at various stages of the test. Tool velocity 40 mm/min. Time (τ) and load F are given in the table. The longest isotherm in each figure is for the temperature 25°C. The step between the isotherms is 5°C.



Rys. 6. Pola temperatur na próbce nr 3 rozciąganej z prędkością 40 mm/min; najdłuższa izoterma odpowiada temperaturze 25°C, różnica temperatur dwóch kolejnych izoterm wynosi 5°C

Temperature fields in the sample 3 at various stages of the test. Tool velocity 40 mm/min. Time (τ) and load F are given in the table. The longest isotherm in each figure is for the temperature 25°C. The step between the isotherms is 5°C.



Rys. 7. Rozkład temperatur i odkształceń w momencie rozzerwania próbki nr 1

Rys. 8. Rozkład temperatur i odkształceń w momencie rozzerwania próbki nr 2

Fig.7. Temperature field and the strain distribution at the moment of crack in the sample 1.

Fig.8. Temperature field and the strain distribution at the moment of crack in the sample 2.

Propozycja prób zrywania z prędkością odkształcenia rzędu $10^2 \text{s}^{-1} \leq \dot{\epsilon} \leq 10^4 \text{s}^{-1}$ /
Kotkowski K., Obróbka Plastyczna, XI, 2, 1972, 75-80 (**Suggestion of a tensile
test with deformation velocities in the range $10^2 \text{s}^{-1} \leq \dot{\epsilon} \leq 10^4 \text{s}^{-1}$**)

OBRÓBKA PLASTYCZNA TOM XI ZESZYT 2

UKD 620.172.254

MGR INŻ. KRZYSZTOF KOTKOWSKI
Politechnika Poznańska

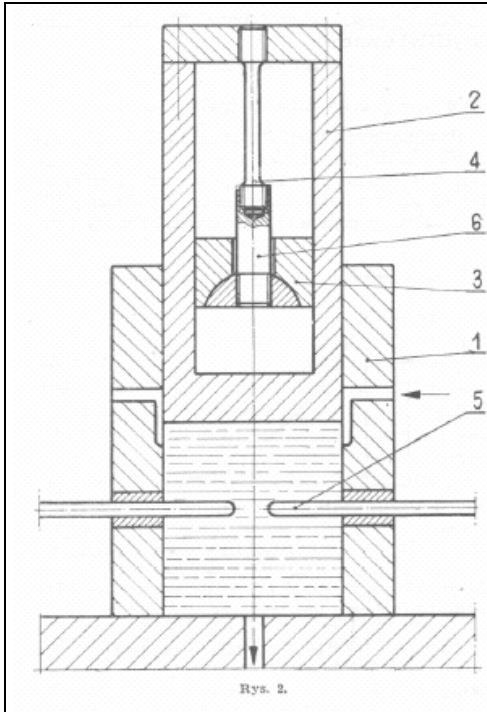
Propozycja prób zrywania z prędkością odkształcenia rzędu $10^2 \text{s}^{-1} \leq \dot{\epsilon} \leq 10^4 \text{s}^{-1}$

SUGGESTION OF A TENSILE TEST WITH DEFORMATION VELOCITIES IN THE RANGE $10^2 \text{s}^{-1} \leq \dot{\epsilon} \leq 10^4 \text{s}^{-1}$

The scheme of an apparatus to perform dynamic tensile tests is presented. The tensile pulse is generated by the underwater discharge method. A mathematical analysis of the tensile test mechanism is given. For stress measurement in dynamic conditions a quasistatic method is proposed and the suitability of resistance strain gages to record short impulse processes is considered.

Strains may be measured by the photometric method, by means of a non-inert light flux.

The measuring possibilities and accuracy of the suggested electric converter system are discussed. The application of a two-channel cathode ray oscilloscope allows to record in time stresses σ -t and strains ϵ -t, as well as — directly — the tensile diagram σ - ϵ , and to determine the mean deformation velocity $\dot{\epsilon}_m$.



Schemat proponowanego urządzenia pokazuje rys. 2. Próbkę 4 swym jednym końcem zamocowana jest w dynamometrze 6, który z kolei połączony jest kulistym łożyskowaniem z belką poprzeczną 3. Belka związana jest na stałe z korpusem cylindra 1. Drugi ruchomy koniec próbki połączony jest z tłokiem 2. Pomiedzy elektrodami 5 następuje rozładowanie prądu z kondensatorów. Powstaje fala uderzeniowa ciśnienia wody. Energia fali przekazana jest przez tłok 2 na próbkę 4. Ruch tłoka w górę może trwać aż do osiągnięcia belki poprzecznej 3, która pełni też rolę zderzaka.

Schematic illustration of the machine. 1 – cylinder, 2 – piston, 3 – traverse, 4 – sample, 5 – electrodes, 6 – load gauge.

When the electric arc appears between the electrodes 5, the wave of the water is created and it acts on the piston and, in consequence, on the sample.

Rola wskaźnika kształtu próbki wytrzymałościowej w statycznej próbie rozciągania / Misiołek, Z ; Prace Instytutów Hutniczych, 4, 1970, 179-196 (**The role of the test-pieces shape factor in the tensile tests**)

Z. Misiołek

THE ROLE OF THE TEST-PIECE SHAPE FACTOR IN THE TENSILE TESTS

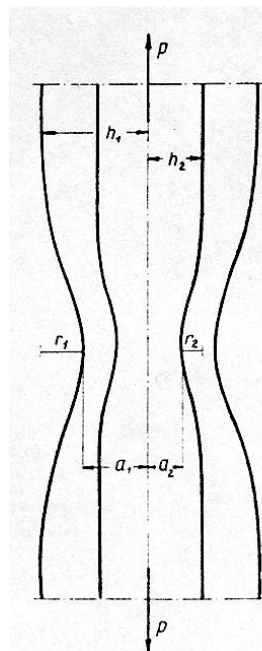
Summary

A survey is made of published comments on the effect of the geometry of rectangular section test-piece on mechanical properties as revealed by the tensile tests. The shape and dimensions of test-pieces are

described, and the way of procedure and the results of tensile tests which were carried out with a series of fivefold test-pieces for test-pieces for aluminium A1, brass M63 and low-carbon 15Y steel, are discus-

sed. A statistical evaluation of the influence of the test-piece shape factor on the strength and plastic properties — represented by the width to thickness ratio in the gauge length portion — is described. The investigations have shown that the tensile strength is not dependent on the shape factor of the test-pieces, on the other hand they have also proved that the shape factor has an inversely proportional effect on the elongation and the reduction in area. Respective functional relationships, and correction coefficients for elongation and the reduction in area have been established, thus permitting to determine on

rectangular section test-pieces of arbitrary shape factor their representative values for the metal and the test-pieces non affected by the shape. The determined dependency of elongation on the width, at a constant thickness, was confirmed by an analysis of stress distribution and the deformation in the gauge length portion of the test-pieces. It was also experimentally established, and than confirmed by a mathematical analysis that the deformation of test-pieces during the tensile strains takes place mainly at the expense of their width primarily in the zone of the elongation in the neck.



Rys. 4. Modelowe przedstawienie kształtu próbek w czasie tworzenia się szyjki

Model of the test piece shape during the formation of the neck

Results examples

Statistical characteristic of mechanical properties of aluminium samples

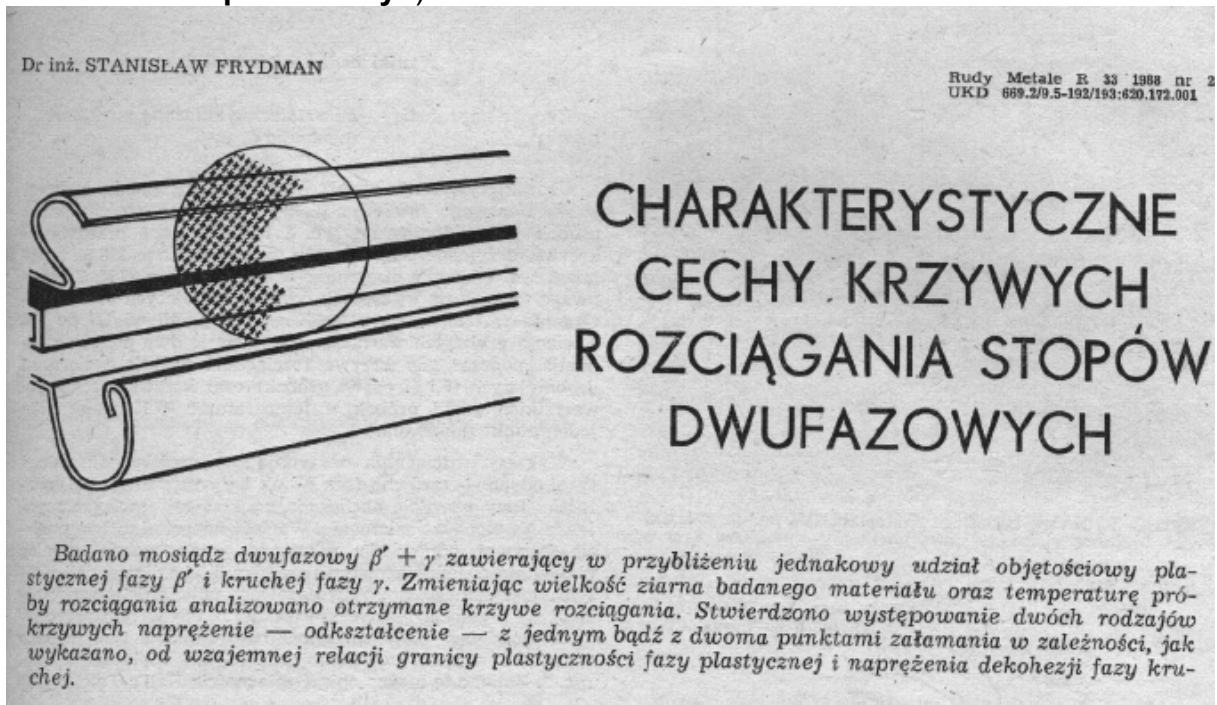
Tablica 12

Statystyczna charakterystyka własności mechanicznych badanych próbek aluminium A1

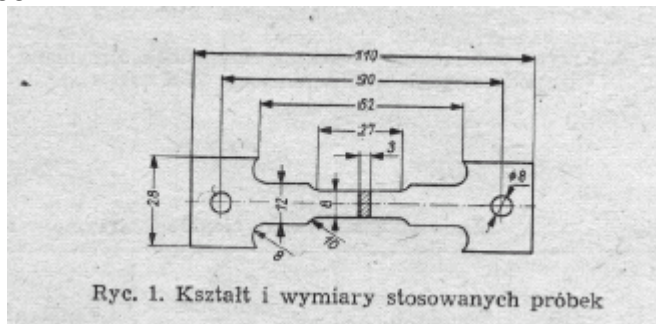
Lp.	Wskaźnik kształtu	Ilość próbek	Średnia	Rozstęp	Wariancja S^2	Odchylenie standardowe S	Przedział ufności na poziomie istotności $\mu(0,05)$	Współczynnik zmienności v	λ	$P(\lambda)$
Wytrzymałość na rozciąganie R_m										
1	M1	16	13,475	1,0	0,136	0,368	13,279 ÷ 13,671	2,73	0,8800	0,3900
2	M5	13	12,871	0,6	0,036	0,190	12,656 ÷ 12,986	1,48	0,4788	0,9600
3	M8	13	13,022	0,6	0,040	0,202	12,902 ÷ 13,144	1,53	0,6590	0,7900
4	M12	13	13,438	1,3	0,087	0,295	13,260 ÷ 13,616	2,19	0,6100	0,8600
Wydłużenie A_5										
1	M1	16	14,269	2,4	0,589	0,767	13,860 ÷ 14,678	5,38	0,6400	0,7900
2	M5	13	8,956	3,67	1,282	1,132	8,274 ÷ 9,638	12,64	0,1330	1,0000
3	M8	13	8,816	1,63	0,361	0,601	8,453 ÷ 9,179	6,82	0,6500	0,7900
4	M12	13	7,408	0,24	0,495	0,495	7,109 ÷ 7,707	6,68	0,5000	0,9600
Przewężenie c										
1	M1	16	68,1250	8,7	6,7154	2,5914	65,302 ÷ 70,948	3,80	0,3200	0,9900
2	M5	13	62,5385	9,0	8,8676	2,9779	59,294 ÷ 65,782	4,62	0,1200	1,0000
3	M8	13	60,8231	8,2	11,6969	3,4201	57,097 ÷ 64,549	5,62	0,6500	0,7900
4	M12	13	59,0692	8,0	4,9539	2,2258	56,644 ÷ 61,494	3,77	0,1800	1,0000

Similar results for steel and for steel 15Y are presented in the paper.

Charakterystyczne cechy krzywych rozciągania stopów dwufazowych / Frydman, S ; Rudy i Metale Nieżelazne, 33, 2, 1988, 55-57 (**Characteristic of tension curves of two-phase alloys**)

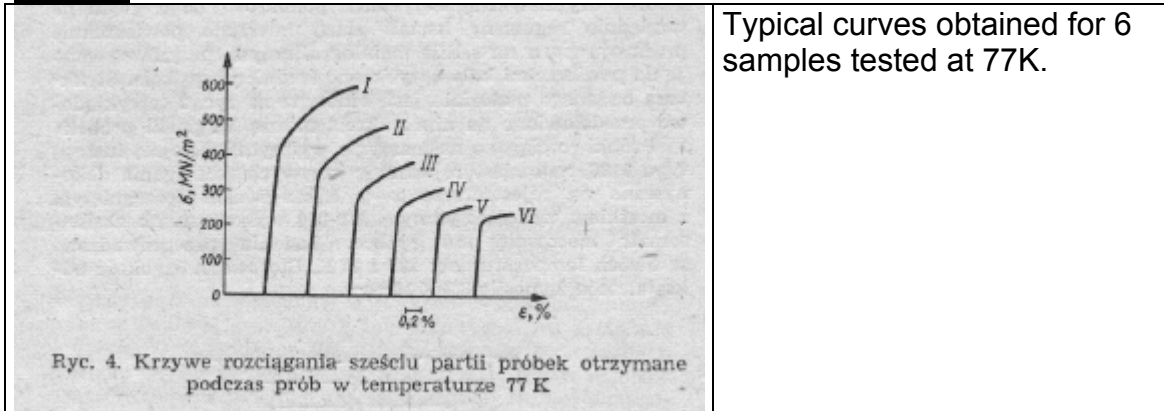


Two-phase brass $\beta + \gamma$ was investigated. The volume fractions of phases were close to 50%. The varying parameters of the tests were grain size and temperature. Results in the form of tensile curves were analysed. Two types of stress-strain curves were distinguished (with one or two points of rapid change of the slope). It is shown in the paper that the type of the curve depends on the ratio between yield stress of the ductile phase and decohesion stress of the rigid phase.



Shape and dimensions of samples.

Results



Typical curves obtained for 6 samples tested at 77K.

TRANSLATED ABSTRACTS OF THE SELECTED MOST IMPORTANT POLISH PAPERS:

1. Uwagi o normie PN-62/H-04310 "Próba statyczna rozciągania metali"

Remarks on the standard PN-62/H-04310 "Static tensile test of metals"

B. Baranowski: Hutnik, XXX, 12, 1963, 387-389.

Abstract: The general characteristic of the norm is presented in the paper. It is emphasized that the norm should follow the progress in methods of testing of materials. The following aspects of the norm are discussed: definition of the flow stress, the yield stress and the tensile strength, measurement of elongation, tensometer, sample geometry. Author discusses all these aspects and gives the suggestions of changes, which should be introduced in order to make the norm more precise.

Key words: Material: general; Samples: cylindrical, flat; Specimen geometry; Rate control: extensometer, Low temperature

2. Praktyczne wyznaczanie wydłużenia równomiernego próbek blach w prostej próbie rozciągania

Practical assessment of the uniform elongation of sheet-metal specimens in standard tension test

A. Turno, Obróbka Plastyczna, IX, 2, 1970, 243-269.

Abstract: The uniform elongation is an important characteristic of material deformability. The paper deals with the problem of determination of the zone of uniform deformation in the conventional tensile tests. Authors refer to the Polish and Russian norms, which define the uniform elongation. Then they investigate an influence of inhomogeneity of the sample on the zone of uniform elongation. The following parameters are investigated: variations of dimensions within the range allowed by the norms, strain rate sensitivity, inhomogeneity of microstructure, texture, dislocation density and defects. Various criteria of determination of the uniform elongation zone are compared for both cylindrical and flat samples. Various types of samples are investigated, including SOLLAC two stage samples. The general conclusion of the work is the method of interpretation of tensile test graphs. This method allows to obtain more consistent

results from different tests. Finally, the definition of strain and elongation inhomogeneity is proposed in the paper.

Key words: Material: Steel, Aluminium; Samples: cylindrical, flat; Specimen geometry; Strain rate sensitivity; Uncertainty: error; Low temperature

3. Porównanie dokładności pomiarów granicy plastyczności przy podwyższonych temperaturach

Comparison of accuracy of yield point measurement at elevated temperatures

R. Kozłowski, Wiadomości Hutnicze, XXVI, 11, 1970, 245-248

Abstract: The objective of the work is comparison of results of tensile tests performed at various laboratories. The testing machines were compared first. Three parameters of the machines were investigated: accuracy of measurement of loads, accuracy of measurements of elongation, accuracy of temperature control. The conclusions compose evaluation of precision of various machines.

Key words: Material: Steel; Samples: cylindrical; Rate control: extensometer; Round robin; Measuring systems; High temperature, Low temperature

4. Mikrostrukturalne zjawiska w strefie szyjki rozciąganej próbki stalowej

Phenomena of microstructural character in the necking of a tensile test piece during tension tests

S. Rudnik, R. Wielgosz; Hutnik, 38, 5, 1971, 259-262

Abstract: *The discontinuities formed in the deformed metal. The character of discontinuities in the necking of a tensile test piece during tension. The methods employed in investigating the discontinuities.*

Key words: Material: Armco iron; Samples: cylindrical

5. Propozycja prób zrywania z prędkością odkształcenia rzędu $10^2\text{s}^{-1} \leq \dot{\epsilon} \leq 10^4\text{s}^{-1}$

Suggestion of a tensile test with deformation velocities in the range $10^2\text{s}^{-1} \leq \dot{\epsilon} \leq 10^4\text{s}^{-1}$

K. Kotkowski, Obróbka Plastyczna, XI, 2, 1972, 75-80

Abstract:

The scheme of an apparatus to perform dynamic tensile tests is presented. The tensile pulse is generated by the underwater discharge method. A mathematical analysis of the tensile test mechanism is given. For stress measurement in dynamic conditions a quasistatic method is proposed and the suitability of resistance strain gages to record short impulse processes is considered. Strains may be measured by the photometric method, by means of a non-inert light flux. The measuring possibilities and accuracy of the suggested electric converter system are discussed. The application of a two-channel cathode ray oscilloscope allows to record in time stresses and strain, as well as, directly, the tensile diagram and to determine the mean deformation velocity.

Key words: Material: General; Measuring systems

6. Pole temperatur powierzchni próbki statycznie rozciąganej

Temperature field on the surface of a statically deformed tensile test piece

J. Mazurkiewicz, J. Budak, *Obróbka Plastyczna*, XIV, 4, 1975, 219-224

Abstract: The strain nonuniformity cause nonuniform temperature rise in the strained test piece. The temperature fields are determined by means of a thermo vision apparatus. The necking locus may be determined by this method before the maximum tensile load is reached. The local temperature rise in the statically strained test piece exceeds 30°C. The temperature nonuniformity advances during necking.

Key words: Material: steel, Samples: flat; Measuring system; Specimen geometry; Uncertainly: scatter; Low temperature

7. Nowa definicja umownej granicy plastyczności i metody jej wyznaczania

Proposal of a new definition of the proof stress in the tensile test and a method for its measurement

M. Grzymkowski; *Obróbka Plastyczna*, XVIII, 2, 1979, 69-72

Abstract: A new method to determine the proof stress at the point of the greatest curvature of the experimental stress-strain curve is proposed. The association of the proof stress with the point of the greatest curvature seems to have a physical justification. This point may be determined graphically or analitically through the approximation of the stress-strain curve by means of a second order polynomial. Three other methods for the evaluation of the proof stress now in use are mentioned: the method of conventional proof stress preferred by the engineers, the method of the tangent and the method of the secant.

Key words: Material: Metals, alloys; New method to determine the proof stress

8. Czułość na prędkość odkształcenia cynku w temperaturze otoczenia

Strain rate sensitivity of zinc at room temperature

K. Pięła; *Rudy i Metale Nieżelazne*, 27, 8, 1982, 361-364

Abstract: The objective of the work is investigation of strain rate sensitivity of materials' flow stress. Tensile tests are used in the investigation. The test were performed for various constant strain rates and for strain rates varying during the test. The tested material was zinc. The results of the analysis were correlated with the microstructure evolution. It was concluded that relationship $\ln(\sigma) - \ln(\dot{\epsilon})$ is divided into two linear parts. Division is connected with the beginning of the process of twinning. Appearance of twins results with an increase of strain rate sensitivity.

Key words: Material: zinc, Samples: cylindrical, Strain rate sensitivity,

9. Charakterystyczne cechy krzywych rozciągania stopów dwufazowych

Characteristic of tension curves of two-phase alloys

S. Frydman, *Rudy i Metale Nieżelazne*, 33, 2, 1988, 55-57

Abstract: Two phase brass was investigated. The material contained approximately equal volume fractions of plastic phase β and rigid phase γ . Analysis of tensile test results vor various grain size of the material and for various temperatures was performed. It was observed that two types of stress-

strain curves are possible. The curves can have one or two breaking points. It is shown in the paper that the type of the curve depends on relative relation between yield stress of the plastic phase and the decohesion stress of the rigid phase.

Key words: Material: Brass; Samples: cylindrical; Specimen geometry; Strain rate sensitivity; Uncertainty: error; High temperature

10. Możliwości określenia parametrów zmęczeniowych stali z próby rozciągania Possibilities of evaluation of fatigue parameters of steel by means of tensile test

S. Cesarz, J. Kucera, T. Kufa, Prace IMŻ, 1989, 1-2, 32-46

Abstract: Results of low-cycle fatigue tests obtained in VUHZ – Dobra and IMZ – Gliwice and literature data for a number of steels manufactured in USSR, USA and JAPAN (185 heats in all) were used in an attempt to establish a correlation between the more easily obtainable tensile strength data and parameters of low-cycle fatigue. In logarithmic coordinates a linear relation was obtained between tensile strength and the parameters of low-cycle fatigue. The data were also used for evaluation of relation between fatigue strength and threshold plastic strain on one side and tensile strength on the other. The results make it possible to predict low-cycle fatigue parameters at constant strain amplitude for steels in which for various reasons the precise value are not known but needed for safe and economical design.

Key words: Material: Steel; Uncertainty: scatter, error; Round robin experiment

11. Rola wskaźnika kształtu próbki wytrzymałościowej w statycznej próbie rozciągania

The role of the test-pieces shape factor in the tensile tests

Z. Misiólek, Prace Instytutów Hutniczych, 4, 1970, 179-196

Abstract: *A survey is made of published comments on the effect of the geometry of rectangular section test-piece on mechanical properties as revealed by the tensile tests. The shape and dimensions of test-pieces are described, and the way of procedure and the results of tensile tests which were carried out with a series of fivefold test-pieces for test-pieces for aluminium Al, brass M63 and low-carbon 15Y steel, are discussed. A statistical evaluation of the influence of the test-piece shape factor on the strength and plastic properties – represented by the width to thickness ratio in the gauge length portion – is described. The investigations have shown that the tensile strength is not dependent on the shape factor of the test-pieces, on the other hand they have also proved that the shape factor has an inversely proportional effect on the elongation and the reduction in area. Respective functional relationships, and correction coefficients for elongation and the reduction in area have been established, thus permitting to determine rectangular section test-pieces of arbitrary shape factor their representative values for the metal and the test-pieces non affected by the shape. The determined dependency of elongation on the width, at a constant thickness, was confirmed by an analysis of stress distribution and the deformation in the gauge length portion of the test-pieces. It was also experimentally established, and than confirmed by a mathematical analysis that*

the deformation of test-pieces during the tensile strains takes place mainly at the expense of their width primarily in the zone of the elongation in the neck.

Key words: Material: aluminum, brass, low-carbon steel; Specimen form, specimen geometry: parallel/gauge length ratio, width/thickness.

APPENDIX 2b. List of Papers relating to Tensile Testing compiled during NAS- TENSTAND Project b) Russian Papers

	Russian	
1.	Soprotivlenie deformacii stalej i splavov v kholodnom sostoyanii / L.V. Andrejuk: Stal, 8, 1973, 731-734. (Resistance to deformation of steels and alloys in cold forming)	1973
2.	Temperaturno-skorostnaya zavisimost soprotivleniya metallov plasticheskoj deformacii / B.A. Migachev, E.L. Vorobyova: Stal, 12, 1973, c. 1108-1109. (Relation of materials resistance to deformation on temperature and strain rate}	1973
3.	7855-74 Mashiny razryvnye i universalnye dla staticheskikh ispytaniy metallov i konstruktivnykh plastmas. (Machines for tensile testing and general testing for static testing of metals and construction materials.	1974
4.	Ekspperimentalnoe issledovanie uprochneniya-razuprochneniya uglerodistykh i srednelegirovannykh slalej / L.N. Sokolov, V.N. Efimov: Izvestiya, Chernaya Metallurgiya, 11, 1980, 80-83 (Experimental investigation of softening of low carbon and alloyed steels) Key words: Material: Steel; Samples: cylindrical; High temperature	1980
5.	K postroeniu diagramm rastyazheniya metallicheskich materialow s uchetom deformatsionnoj anizotropii / V.N. Bastun: Zavodskaya Laboratoriya, 9, 1981, 32-34 {Building of tensile test diagrams accounting for anisotropy of deformation) Key words: Material: 45;	1981
6.	Opredelenie ravnomernogo udlineniya po krivym deformacii / Ju.S. Tomenko, I.N. Khristenko, A.A. Pashchenko: Zavodskaya Laboratoriya, 2, 1981, 76-77. (Determination of uniform elongation in tensile testing) Key words: Material: Steel; Samples: cylindrical; Uncertainly: error	1981
7.	Opriedelenye skorosti nagruzenya obrazca pri ispytanyakh na raztyazhenie / L.T. Timoshuk: Zavodskaya Laboratoriya, 6, 1981, 90-93 (Determination of the sample loading rate in tensile testing) Key words: Material: steel; Samples: cylindrical; Uncertainly: error; Low temperature	1981
8.	Metody opredeleniya mekhanicheskikh svoystv stali i osobennosti ee povedeniya .pri nizkikh skorostyakh deformirovaniya. / V.A. Baladin, V.N. Potapov: Zavodskaya Laboratoriya, 5, 1981, 67-70 (Methodology for determination of mechanical properties of steels and details of performance at low strain rates) Key words: Material: Steel; Samples: cylindrical; Strain rate sensitivity	1981
9.	Osobennosti obrabotki diogrammy rastyazheniya pri staticheskikh ispytaniyakh	1981

	materialov na rastyazhenie / N.A. Chinaev, V.M. Sotnikov: Zavodskaya Laboratoriya, 9, 1981, 92-93 (Details of treatment of static tensile test plots) Key words: Material:	
10.	O mikroplastichnosti i prochnosti ferritov Mn-Zn / A.M. Savelev, A.P. Korolev, V.P. Shelokhvostov, S.P. Travkin: Zavodskaya Laboratoriya, 7, 1982, 79-81 {About microplasticity and strength of Mn-Zn ferrites) Key words: Material: ferrite Mn-Zn;	1982
11.	Metodika prigotovleniya mikroobrazcov dla rastyazheniya v kolonne elektronnoho mikroskopa / V.A. Ermishkin, E.N. Samoylov, V.G. Sabitov: Zavodskaya Laboratoriya, 11, 1982, 60-61 (Methodology for sample preparation for tensile tests) Key words: Material: Molibden, Alloys Ni-Fe, Fe, Aluminium;	1982
12.	Pokazatel napryazhonnogo sostoyaniya pri vysokoskorostnom rastyazhenii. / N.A. Chelyshev, V.Ja. Lyuc, G.A. Chervov: Izvestiya, Chernaya Metallurgiya, 10, 1983, 48-50 (State of stress factor at high strain rate tensile testing) Key words: Material: Steel;	1983
13.	O plasticheskom deformirovanii uprochnyaushchikhsya metallov i splavov. Analiz dannykh eksperimentov i reshenie uprugoplasticheskikh zadac / A.N. Mokhel, R.L. Salganik, S.A. Khristianovich: Mekhnika tvyordogo tela, 5, c 81-102. 1983. (About plastic deformation of strain-hardening metals and alloys. Analysis of experimental data and solution of elastic-plastic problems)	1983
14.	Vliyanie formy poperechnogo secheniya obrazca na vid deviatora napryazhenij pri rastyazhenii / A.A. Bogatov, A.B. Vydrin, V.L. Kolmogorov: Izvestiya, Chernaya Metallurgiya, 12, 1983, 50-52 (Influence of shape of sample's cross section on the deviator of stress tensor in tensile tests) Key words: Material: Aluminium, Steel; Samples: specimen geometry, rectangle	1983
15.	Ustroystvo dla ispytaniya materyalov na razryv pri vysokikh gidrostaticheskikh davlenyah / A. I. Kolpashnikov, A.A. Fedorov, B.V. Kucheryayev, A.B. Biespalov: Zavodskaya Laboratoriya, 11, 1983, 77-78. (Device for tensile testing of materials under high hydrostatic pressure in) Key words: Material: Bronz, Niob; Samples: cylindrical; Low temperature	1983
16.	Ustanovka dla polucheniya dinamicheskikh diagramm rastyazheniya metalla / V.A. Vinokurov, O.C. Shanshaev: Zavodskaya Laboratoriya, 5, 1983, 78-81 (Apparatus for making dynamic plots in tensile tests) Key words: Material: Steel; Strain rate sensitivity, Measuring system	1983
17.	Prisposoblenie dla staticheskikh i dinamicheskikh ispytanij metallov na rastyazhenie pri temperaturach ot +80 do -196 °C / E.I. Pinchuk, A.V.	1983

	Rachkov, A.V. Egorov: Zavodskaya Laboratoriya, 3, 1983, 75-76 (Apparatus for static and dynamic tensile testing of materials at temperature range +80 do -196 °C) Key words: Material	
18.	1497-84 Metally. Metody ispytaniya na rastyazhenie.	1984
19.	11150-84 Metally. Metody ispytaniya na rastyazhenie pri ponizhenykh temperaturakh.	1984
20.	Mekhanicheskie ispytaniya metallov. Moskva.: Vysshaya shkola, 1986. 199 (Mechanical behaviour of metals)	1986
21.	Soprotivlenie nekotorykh materialov chistomu rastyazheniu i szhatiu / Zhukov A.M.: Mekhanika tvyordogo tela, 4, 1986,197-202. (Resistance to deformation of some materials in tension and compression)	1986
22.	Issledovanie razvitiya deformacii naimenshego secheniya obrazca pri rastyazhenii / B.A. Nikiforov, F.T. Mustafin, L.E. Kandaurov: Izvestiya, Chernaya Metallurgiya, 11, 1986, 71-74 (Investigation of development of deformation at the sample cross section in tensile tests) Key words: Material: Steel; Samples: Measuring system: frequency.	1986
23.	Issledovanie soprotivleniya deformarmacii stalej s ispolzovaniem metodov planirovaniya eksperimenta / E.S. Khloponin, V.N. Titlyanov, A.E. Zobnin, A.D. Gridnev: Stal, 6, 1986 c. 530-531. (Investigation of resistance to deformation of steels using the methods of planning of experiments)	1986
24.	Ispytanye materialov na raztyazhenye pod vysokim gidrostaticheskim davlenyem. / A.T. Gayvoronskiy, Ju. V. Frolov: Zavodskaya Laboratoriya, 6, 1987, 71-73. (Tensile testing of materials under high hydrostatic pressure) Key words: Material: steel; Samples: cylindrical; Gripping; Low temperature	1987
25.	Vybor obrazca dla opredeleniya prochnostnykh kharakteristik pri razlichnykh skorostyakh raztyazhenia / M.M. Astahov, O.G. Kudryavcev, A.V. Loginov, L.P. Loshmanov, A.E. Trocenko. Zavodskaya Laboratoriya, 5, 1988, 73-76 (Selection of sample for determination of hardening characteristics for various velocities of tension) Key words: Material: steel; Samples: cylindrical; Gripping; Specimen geometry; Low temperature	1988
26.	Izmienenyenye skorosti deformacii i otnoshenya diametr obrazca k radiusu wytochki pri vysokoskorostnom rastyazhenii cylindicheskikh obrazcov / V. Ja. Luc, N.A. Chelyshev, V.I. Petrov: Izvestiya, Chernaya Metallurgiya, 2, 1988, 74-79 (Changes of deformation rate and sample diameter – to - transition radius ratio in high velocity tensile testing of cylindrical samples) Key words: Material: Steel, aluminium; Samples: cylindrical; Specimen	1988

	geometry; Uncertainly: error; Low temperature	
27.	Predelnoe sostoyanie shejki proizvolnogo ochertaniya v zhostkoplachesticheskom tele / Radaev Ju. N.: Mekhanika tvyordogo tela, 6, c. 69-75. 1988. (Prediction of neck formation if the rigid-plastic body)	1988
28.	Avtomatirizovannaya metodika perestroyki diagram vysokotemperaturnovo raztyazheniya monokristallov v koordinatakh istynnyye napryazheniya – istynnyye deformacii / V.I. Levit, O.N. Mysakova: Zavodskaya Laboratoriya, 5, 1989, 74-76 (Automatic transformation of high temperature testing plot for mono-crystals in coordinates effective stress – effective strain) Key words: Material: mono-crystal – alloy HN77TJR; Samples: cylindrical; High temperature	1989
29.	Metodika isspytaniya tonkikh ploskikh obrazcov konstrukcionnykh materialov pri vysokikh rastyazhenii / A.N. Golenchenko, M.M. Astrakhov, A.V. Loginov, L.P. Loshmanov: Zavodskaya Laboratoriya, 8, 1989, 87-88 Methodology for testing of thin samples at high strain rates Key words: Material: Steel; Samples: ; Gripping	1989
30.	Metodika ispytaniy na rastyazhenie ploskikh obrazcov iz transportnykh listovykh materialov / Ju. G. Vazencev: Zavodskaya Laboratoriya, 8, 1989, 87-88 (Tensile testing method for flat samples made of automotive materials) Key words: Material: Steel; Samples: rectangular; Low temperature	1989
31.	Metodika issledovaniya sklonnosti slaley k deformirovannomu uprochneniyu po rezultatam ispytaniya razrywnnykh obrazcov / B.P. Safonov: Zavodskaya Laboratoriya, 10, 1991, 32-34 (Method of investigation of steel tendency to work hardening in tensile test) Key words: Material: Steel; Samples: specimen geometry, rectangle	1991
32.	Avtomatizirovannoe opredelenie uslovnogo predela tekuchesti pri ispytanii metallov na rastyazhenie / A.D. Zotov, M.A. Afinogenova, V.G. Kokorin: Zavodskaya Laboratoriya, 7, 1991, 34-35 (Automatic determination of proof stress in tensile tests) Key words: Material: 29NK-VI	1991
33.	Dopolnityelnyye kharakteristiki mekhanicheskikh svoystv staley, opredelayemye pri ispytanii materyalov na rastyazhenie / G.M. Sorokin, B.P. Safonov, V.P. Yeroshkin: Zavodskaya Laboratoriya, 9, 1993, 53-57 (Additional mechanical characteristics of steel properties, determined in tensile testing) Key words: Material: Steel; Samples: cylindrical; Low temperature	1993
34.	Sposob piereshcheta otnositelno udlinieniya i novyj parametr plastichnosti / S.W.N. Geminov, A.G. Kolmakov: Zavodskaya Laboratoriya, 5, 1993, 32-34 (Method of calculation of relative elongation and new parametr of	1993

	plasticity) Key words: Material: Molybdenum; Samples: cylindrical; Specimen geometry; Uncertainly: error; Low temperature	
35.	Vliyanie vida kholodnoj deformacii na prochnost niskouglerodistoj stali / Ju. V. Zilberg, V.G. Bratutin: Sovershenstvovanie procesov i oborudovaniya obrabotki metallov davleniem v metallurgii i mashinostroenii. Tematicheskij sb. Nauchnykh trudov. Kramatorsk. 2002. 468-474. The curves of a mechanical hardening quiet and boiling low – carbon of steels are investigation rolling, draw shaping, stretching and forward bending test. Is show, that at monotone processes the curves of a mechanical hardening are close among themselves, backward and forward bending test the metal or is not hardening is much less, then for monotone processes.	2002

LIST OF THE SELECTED MOST IMPORTANT RUSSIAN PAPERS:

1. Ustroystvo dla ispytanya materyalov na razryv pri vysokikh gidrostaticheskikh davlenyah.

Device for tensile testing of materials under high hydrostatic pressure.

A. I. Kolpashnikov, A.A. Fedorov, B.V. Kucheryayev, A.B. Biespalov: Zavodskaya Laboratoriya, 11, 1983, 77-78.

Abstract: The paper describes the tensile testing device, which was developed by the authors and which allows testing of materials under high hydrostatic pressure. The sample with the tools is located in the container. The container is filled with a special liquid, which is supplied under various pressures. The pressure is maintained constant during the tension. The design of the sample allows maintaining the constant strain rate, as well. The device is simple in maintenance and it allows tensile testing of materials in a wide range of temperatures and under various hydrostatic pressures. Method of selection of composition of the liquid is described in the paper.

Key words:

Material: Bronze, Niobium; Samples: cylindrical; Low temperature

2. Metody opredeleniya mekhanicheskikh svojstv stali i osobennosti ee povedeniya .pri nizkikh skorostyakh deformirovaniya.

Methodology for determination of mechanical properties of steels and details of performance at low strain rates.

V.A. Baladin, V.N. Potapov: Zavodskaya Laboratoriya, 5, 1981, 67-70.

Abstract: The paper presents the methodology for testing the influence of strain rate on mechanical properties of steels. The schematic illustration of the testing machine is presented. Presented results illustrate an influence of strain rate on yield stress and tensile strength. Analysis of results shows that the yield stress decreases by 9-14%, the total elongation decreases by 1.3-1.4 times and the

uniform elongation decreases by 1.4-1.9 times when very low strain rates are applied.

Key words: Material: Steel; Samples: cylindrical; Strain rate sensitivity

3. Metodika issledovaniya sklonnosti slalej k deformirovannomu uprochneniu po rezultatam ispytaniya razrywnykh obrazcov.

Method of investigation of steel tendency to work hardening in tensile test.

B.P. Safonov: Zavodskaya Laboratoriya, 10, 1991, 32-34.

Abstract: A proposition of measurement of steel tendency to strain hardening in tensile tests is proposed in the paper. The method is based on analysis of the level of elastic strain energy, accumulated during the test. Tendency to strain hardening is calculated as the coefficient defined by the value of the elastic strain energy at the strain related to yield stress and to tensile strength $K = (S_w/S_p)^2 + 1$. It should be pointed out that calculations based on this method are sensitive to the stiffness of the machine. The second factor, which was measured, is the work hardening coefficient. The results composing both these coefficient, obtained for various steels, are given in the paper.

Key words: Material: Steel; Samples: specimen geometry, rectangle;

4. Opredelenie ravnomernogo udlineniya po krivym deformacii.

Determination of uniform elongation in tensile testing.

Ju.S. Tomenko, I.N. Khristenko, A.A. Pashchenko: Zavodskaya Laboratoriya, 2, 1981, 76-77.

Abstract: Several approaches, which are used for determination of uniform elongation, are described in the paper. The methods are based on measurements of the sample or on the analysis of the strain hardening curve. Various methods often yield various results. An example of the load-elongation curve for steel St3sp is presented in the paper. This curve does not have the maximum. It is suggested in the paper that the point of initiation of the neck should be taken as the beginning for measurements. Comparison of various method of determination of uniform elongation was performed and the error of each method was evaluated. The method based on graphical interpretation of the strain hardening plot is suggested as the most accurate.

Key words:

Material: Steel; Samples: cylindrical; Uncertainly: error

5. Vliyanie formy poperechnogo secheniya obrazca na vid deviatora napryazhenij pri rastyazhenii

Influence of shape of sample's cross section on the deviator of stress tensor in tensile tests

A.A. Bogatov, A.B. Vydrin, V.L. Kolmogorov: Izvestiya, Chernaya Metallurgiya, 12, 1983, 50-52.

Abstract: The objective of the work was investigation of the influence of the Lode coefficient of the yield stress. The dimensions of the sample cross section are the main parameters, which influence the Lode coefficient. Performed investigation led to a conclusion that this coefficient in the tensile tests is sensitive to the material, as well. The diagram showing relationship between shape tape of

material and factor of the cross section (B/H) and the Lode coefficient are presented in the paper.

Key words:

Material: Aluminium, Steel; Samples: specimen geometry, rectangle

6. Issledovanie razvitiya deformacii naimenshego secheniya obrazca pri rastyazhenii.

Investigation of development of deformation at the sample cross section in tensile tests

B.A. Nikiforov, F.T. Mustafin, L.E. Kandaurov: Izvestiya, Chernaya Metallurgiya, 11, 1986, 71-74.

Abstract: The results of the tensile tests, in which pictures of the sample were taken during deformation, are presented. The sampling rate for the pictures was 30-36 per second. The measurements of strains at the smallest cross section were obtained as a result. These strains are presented as a function of the displacement of the grip. Mathematical function describing development of strain in the tested materials is proposed in the paper. Coefficients in this function for various materials are proposed.

Key words:

Material: Steel; Samples: Measuring system: frequency.

7. Ispytanye materialov na raztyazhenye pod vysokim gidrostaticheskim davlenyem.

Tensile testing of materials under high hydrostatic pressure.

A.T. Gayvoronskiy, Ju. V. Frolov: Zavodskaya Laboratoriya, 6, 1987, 71-73.

The paper describes the tensile testing device, which was developed by the authors and which allows testing of materials under high hydrostatic pressure. Schematic illustration of this device is presented. Tensile tests under various hydrostatic pressures were performed. The results for the steel 50PA are presented.

Key words:

Material: steel; Samples: cylindrical; Gripping; Low temperature

8. Opriedelenye skorosti nagruzenya obrazca pri ispytanyakh na raztyazhenie

Determination of the sample loading rate in tensile testing.

L.T. Timoshuk: Zavodskaya Laboratoriya, 6, 1981, 90-93.

Abstract: According to norms GOST 1497-77 and standard SEV 471-77 the velocity of tensile testing should be selected depending on sample dimensions and elastic properties of the tested material. It is shown in the paper how the load should be changed during the test depending on the current diameter and length. The tests were performed for steel. The method is based on the uniform increments of stress.

Key words:

Material: Steel; Samples: cylindrical; Uncertainly: error; Low temperature

9. Avtomatizirovannaya metodika perestroyki diagramm vysokotemperaturnogo raztyazheniya monokristallov v koordinatakh istinnyje napryazheniya – istynnyje deformacii.

Automatic transformation of high temperature testing plot for mono-crystals in coordinates effective stress – effective strain.

V.I. Levit, O.N. Mysakova: Zavodskaya Laboratoriya, 5, 1989, 74-76.

Abstract: There is one important feature of high temperature tensile testing of monocrystals – the load starts to decrease directly after the elasticity limit is exceeded. Developed method is based on determination of cross section area at few points along the sample and defining the yield stress for varying cross sections. The measurements of the sample shape are approximated for few time steps and the resulting functions are used for determination of the yield stress..

Key words: Material: mono-crystal – alloy HN77TJR; Samples: cylindrical; High temperature

10. Izmienenie skorosti deformacii i otnosheniya diametra obrazca k radiusu vytochki pri vysokoskorostnom rastyazhenii cylindricheskikh obrazcov.

Changes of deformation rate and sample diameter – to - transition radius ratio in high velocity tensile testing of cylindrical samples.

V. Ja. Luc, N.A. Chelyshev, V.I. Petrov: Izvestiya, Chernaya Metallurgiya, 2, 1988, 74-79

Abstract: Influence of dynamic conditions of loading on the strain rate is investigated in the paper. Developed apparatus and the scheme of the measurement system is presented. The apparatus was used for investigation of influence of sample dimensions on the effective strain rate. The crack initiation was monitored by making pictures with the frequency $500\,000\text{ s}^{-1}$.

Key words: Material: Steel, aluminium; Samples: cylindrical; Specimen geometry; Uncertainly: error; Low temperature, frequency.

Vliyanie formy poperechnogo sечeniya obrazca na vid deviatora napryazhenij pri rastyazhenii / A.A. Bogatov, A.B. Vydrin, V.L. Kolmogorov: Izvestiya VUZ, Chernaya Metallurgiya, 12, 1983, 50-52

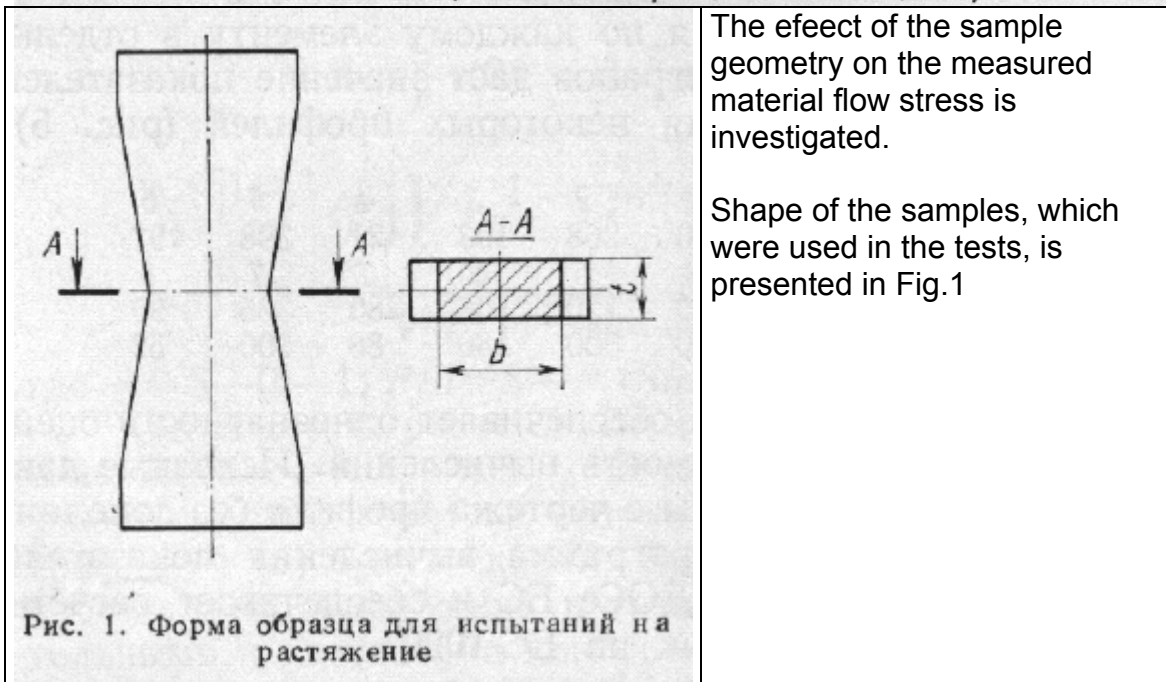
(Influence of shape of sample's cross section on the deviator of stress tensor in tensile tests)

ИЗВЕСТИЯ высших учебных заведений. ЧЕРНАЯ МЕТАЛЛУРГИЯ 12 1983

УДК 621.771.01

**ВЛИЯНИЕ ФОРМЫ ПОПЕРЕЧНОГО СЕЧЕНИЯ ОБРАЗЦА
НА ВИД ДЕВИАТОРА НАПРЯЖЕНИЙ ПРИ РАСТЯЖЕНИИ**

А. А. Богатов, А. В. Выдрин, В. Л. Колмогоров



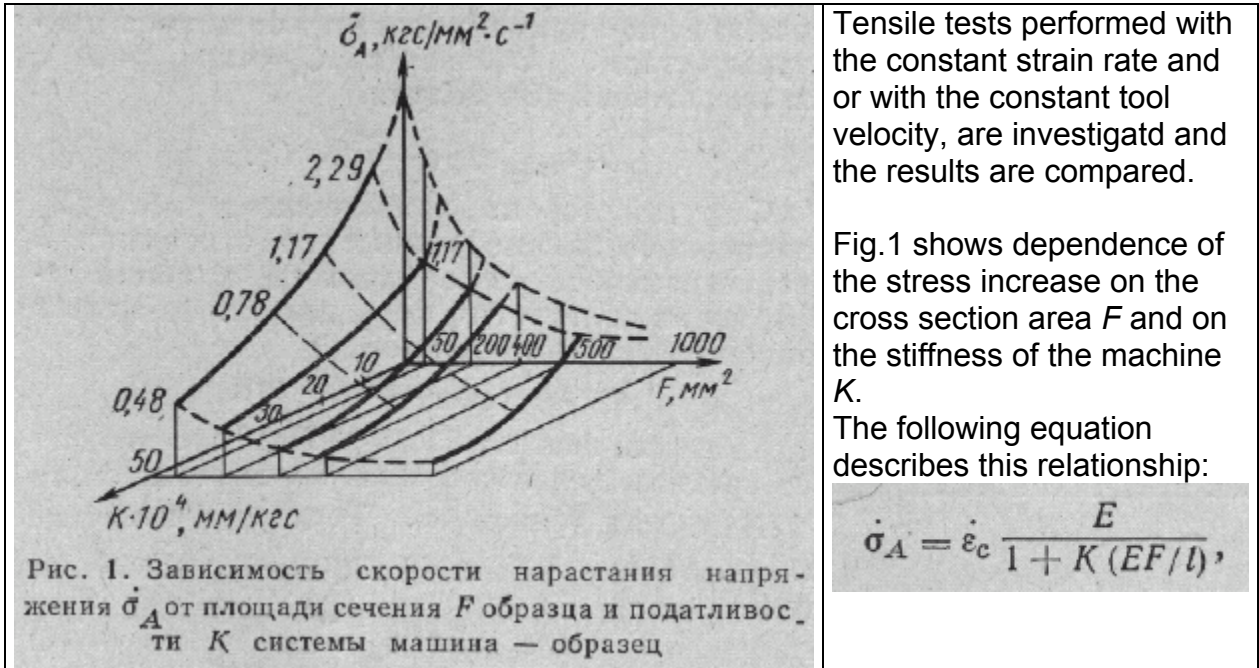
Opriedelenye skorosti nagruzenya obrazca pri ispytanyakh na raztyazhenie / L.T. Timoshuk: Zavodskaya Laboratoriya, 6, 1981, 90-93. (Determination of the sample loading rate in tensile testing)

УДК 620.172.087

Л. Т. ТИМОШУК

ОПРЕДЕЛЕНИЕ СКОРОСТИ НАГРУЖЕНИЯ ОБРАЗЦА
ПРИ ИСПЫТАНИЯХ НА РАСТЯЖЕНИЕ

ЦНИИ черной металлургии им. Бардина, Москва



Tensile tests performed with the constant strain rate and or with the constant tool velocity, are investigated and the results are compared.

Fig.1 shows dependence of the stress increase on the cross section area F and on the stiffness of the machine K .

The following equation describes this relationship:

$$\dot{\sigma}_A = \dot{\epsilon}_c \frac{E}{1 + K(EF/l)},$$

Ustanovka dla polucheniya dinamicheskikh diagramm rastyazheniya metalla / V.A. Vinokurov, O.C. Shanshaev: Zavodskaya Laboratoriya, 5, 1983, 78-81
(Apparatus for making dynamic plots in tensile tests)

УДК 620.172.087.05

В. А. ВИНУКУРОВ, О. Ц. ШАНШАЕВ

**УСТАНОВКА ДЛЯ ПОЛУЧЕНИЯ
 ДИНАМИЧЕСКИХ ДИАГРАММ РАСТЯЖЕНИЯ МЕТАЛЛА**

МВТУ им. Баумана

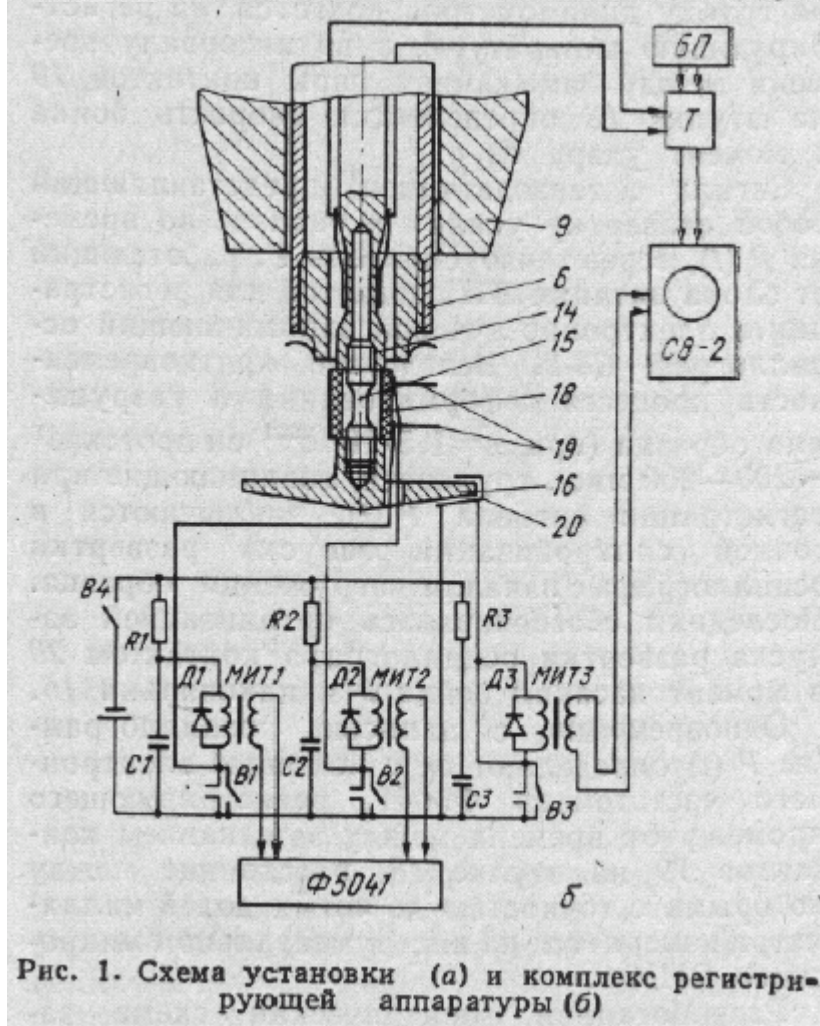


Figure 1 shows the apparatus, which enables change of the grips velocity in the range between 0,01 do 1 mm/s.

$$\dot{\epsilon} = \frac{1}{l_0} \frac{dl_0}{dt} = \frac{v_0}{l_0} = \text{const.}$$

Problem of the influence of waving phenomena on the construction of machines for tensile testing is investigated in the paper. According to the authors the length of the base should be low, around 1.5 - 3 D, where D is the diameter of the

sample. The range of the strain rates used in the experiment was 5.5×10^{-2} - $1.5 \times 10^3 \text{ s}^{-1}$.

Vybor obrazca dla opredelenya prochnostnykh kharakteristik pri razlichnykh skorostyakh raztyazeniya / M.M. Astahov, O.G. Kudryavcev, A.V. Loginov, L.P. Loshmanov, A.E. Trocenko. Zavodskaya Laboratoriya, 5, 1988, 73-76

(Selection of sample for determination of hardening characteristics for various velocities of tension)

УДК 620.178.7:620.172.2

М. М. АСТАХОВ, О. Г. КУДРЯВЦЕВ, А. В. ЛОГИНОВ,
Л. П. ЛОШМАНОВ, А. Е. ТРОЦЕНКО

**ВЫБОР ОБРАЗЦА ДЛЯ ОПРЕДЕЛЕНИЯ ПРОЧНОСТНЫХ
ХАРАКТЕРИСТИК ПРИ РАЗЛИЧНЫХ СКОРОСТЯХ РАСТЯЖЕНИЯ**

Московский инженерно-физический институт

The paper deals with the problem of determination of dimension of samples basing on the analysis of characteristics of the process. The length of the base in the high speed tests was constrained to the minimum value. It is concluded, on the basis of the performed investigation, that there is a limit for the minimum length of the sample, which is imposed by the condition of the uniform stress.

This minimum length should be $\frac{l}{d_0} \geq 1.2$.

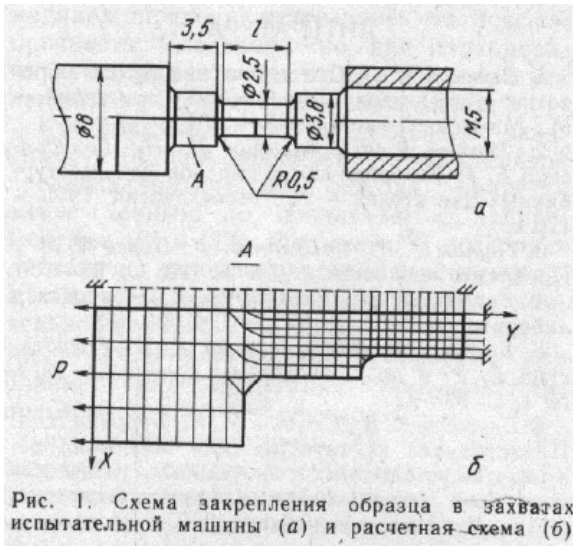


Рис. 1. Схема закрепления образца в захватах испытательной машины (а) и расчетная схема (б)

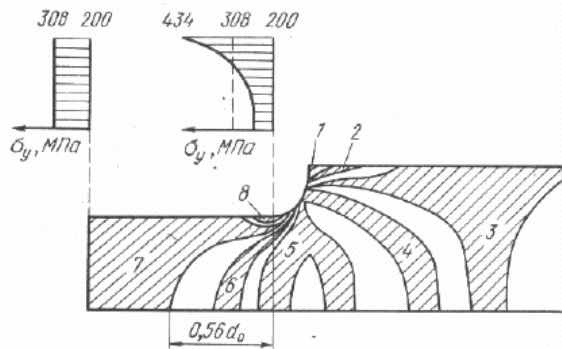


Рис. 5. Поля эквивалентных напряжений и эпюры осевых напряжений (МПа):
 1—8 — 0—25; 51—76; 102—128; 153—179; 204—229; 255—280; 306—331 и 357—383 соответственно

Fig.1. Schematic illustration of the grip (a) and grid for calculations (b)
 Fig.2. The field of the effective stress and plots of axial stresses.

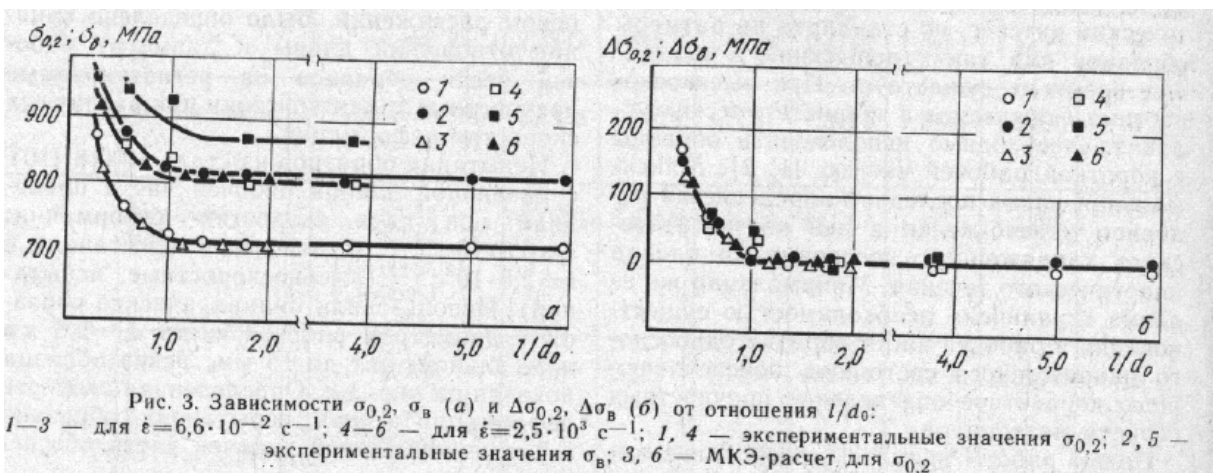


Рис. 3. Зависимости $\sigma_{0,2}$, σ_b (а) и $\Delta\sigma_{0,2}$, $\Delta\sigma_b$ (б) от отношения l/d_0 :
 1—3 — для $\dot{\epsilon}=6,6 \cdot 10^{-2} \text{ с}^{-1}$; 4—6 — для $\dot{\epsilon}=2,5 \cdot 10^3 \text{ с}^{-1}$; 1, 4 — экспериментальные значения $\sigma_{0,2}$; 2, 5 — экспериментальные значения σ_b ; 3, 6 — МКЭ-расчет для $\sigma_{0,2}$

Fig.3. Relationship between the proof stress (a) and increment of the proof stress on the ratio l/d_0 for various strain rates.

Avtomatizirovannaya metodika perestroyki diagram vysokotemperaturnovo raztyazheniya monokristallov v koordinatakh istynnyje napryazheniya – istynnyye deformacii / V.I. Levit, O.N. Mysakova: Zavodskaya Laboratoriya, 5, 1989, 74-76 (Automatic transformation of high temperature testing plot for mono-crystals in coordinates effective stress – effective strain)

УДК 620.171.2:548.55.65.011.56

В. И. ЛЕВИТ, О. Н. МЫСАКОВА

**АВТОМАТИЗИРОВАННАЯ МЕТОДИКА ПЕРЕСТРОЙКИ ДИАГРАММ
ВЫСОКОТЕМПЕРАТУРНОГО РАСТЯЖЕНИЯ МОНОКРИСТАЛЛОВ
В КООРДИНАТАХ ИСТИННЫЕ НАПРЯЖЕНИЯ – ИСТИННЫЕ ДЕФОРМАЦИИ**

Институт физики металлов УрО АН СССР, Свердловск

Methodology for determination of the real strain-hardening curve for monocrystals at elevated temperatures ($T > 0.5T_{cryst}$) is presented in the paper. The main idea is determination of the progress of the tensile process on the basis of measurement of the initial and final shape of the sample. The computer program, which performs relevant calculations and which accounts for influence of anisotropy, was developed and is described in the paper. The methodology was tested for the XH77TЮP alloy, at the temperature 1473 K, with the tool velocity 1 mm/min.

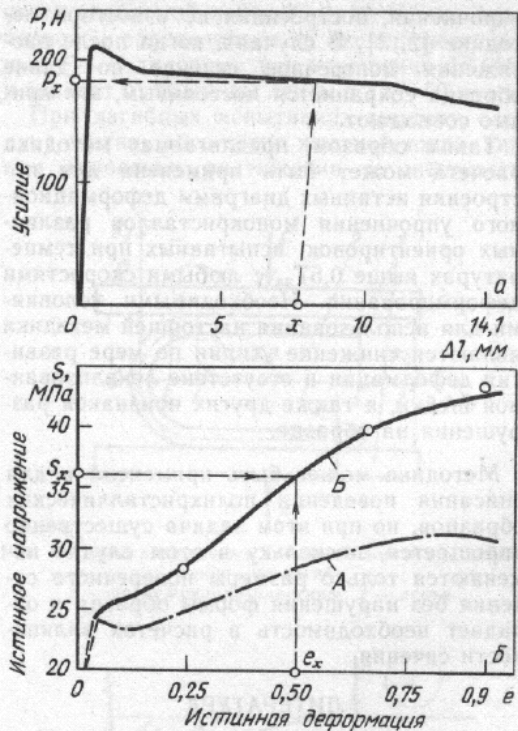


Рис. 1. Машинная диаграмма растяжения (а) и перестроенные кривые деформационного упрочнения (б) монокристалла сплава XH77TЮP

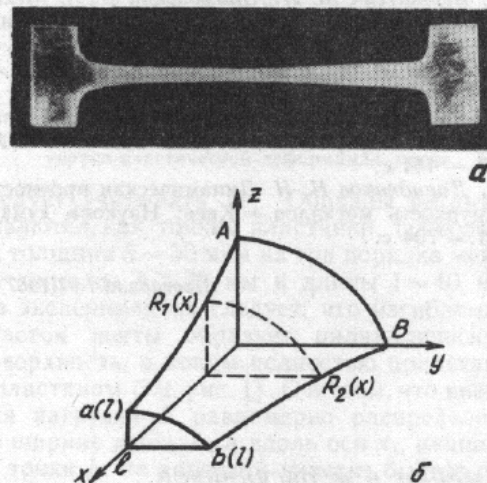


Рис. 2. Фотография (а) и математическая модель (б) образца после высокотемпературной деформации

Fig.1. Monitored plots of loads (a) and stresses (b)

Fig.2. Photo of the sample (a) and mathematical model of the sample after deformation (b)

Metodika ispytaniy na rastyazhenie ploskikh obrazcov iz transportnykh listovykh materialov / Ju. G. Vazencev: Zavodskaya Laboratoriya, 8, 1989, 87-88
(Tensile testing method for flat samples made of automotive materials)

УДК 620.178.6

Ю. Г. ВАЖЕНЦЕВ

**МЕТОДИКА ИСПЫТАНИЙ НА РАСТЯЖЕНИЕ ПЛОСКИХ ОБРАЗЦОВ
ИЗ ТРАНСТРОПНЫХ ЛИСТОВЫХ МАТЕРИАЛОВ**

Ставропольский политехнический институт

The methodology for determination of flow stress and parameters of anisotropy is described.

Zaproponowana metodyka do wyznaczenia naprężenia uplastyczniającego i parametru anizotropii. Zgodnie z użytą inżynierską metodyką można wyznaczyć wartości naprężeń w kierunkach głównych, oraz wartość odkształcenia i naprężenia zastępczego.

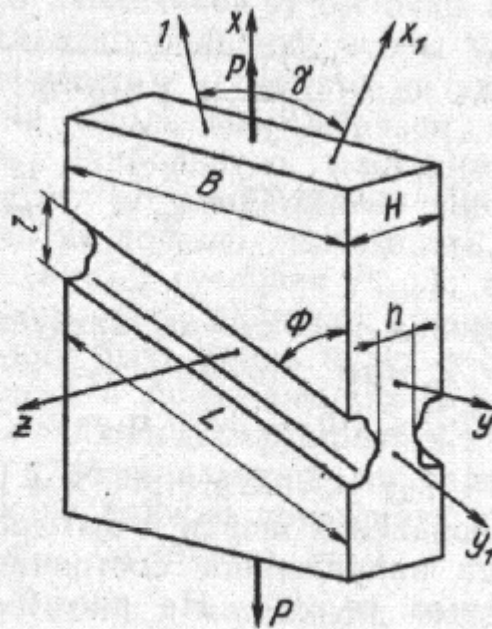


Рис. 1. Схема плоского растягиваемого образца с выточкой

Fig.1. Schematic illustration of the flat sample with a channel. This sample was used for determination of flow stress and anisotropy.

Metodika isspytaniya tonkikh ploskikh obrazcov konstrukcionnykh materialov pri vysokikh rastyazhenii / A.N. Golenchenko, M.M. Astrakhov, A.V. Loginov, L.P. Loshmanov: Zavodskaya Laboratoriya, 8, 1989, 87-88 (**Methodology for testing of thin samples at high strain rates**)

УДК 620.172.242

А. Н. ГОЛЕНЧЕНКО, М. М. АСТАХОВ, А. В. ЛОГИНОВ, Л. П. ЛОШМАНОВ

**МЕТОДИКА ИСПЫТАНИЯ ТОНКИХ ПЛОСКИХ ОБРАЗЦОВ
КОНСТРУКЦИОННЫХ МАТЕРИАЛОВ
ПРИ ВЫСОКОСКОРОСТНОМ РАСТЯЖЕНИИ**

Московский инженерно-физический институт

A new approach to testing of thin flat samples at high strain rates is proposed in the paper.

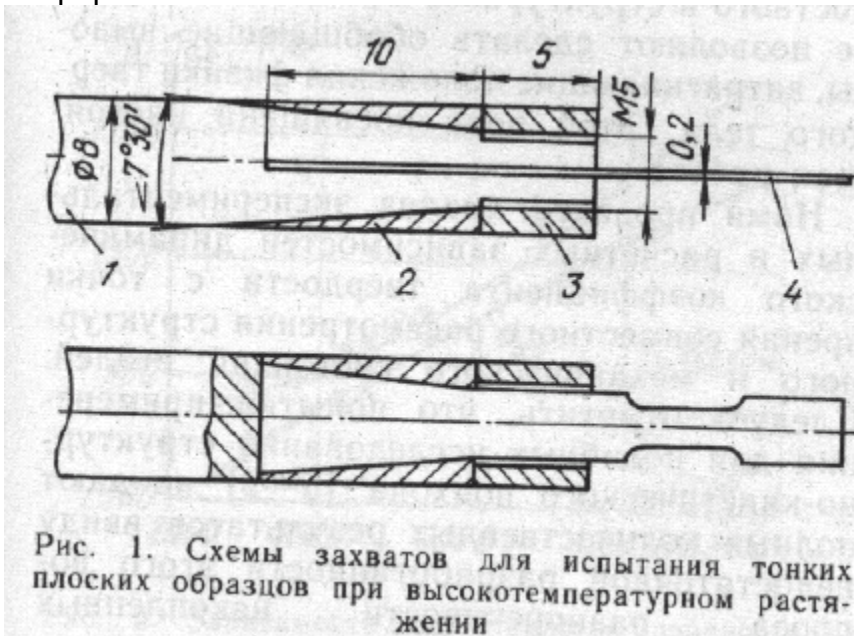


Рис. 1. Схемы захватов для испытания тонких плоских образцов при высокотемпературном растяжении

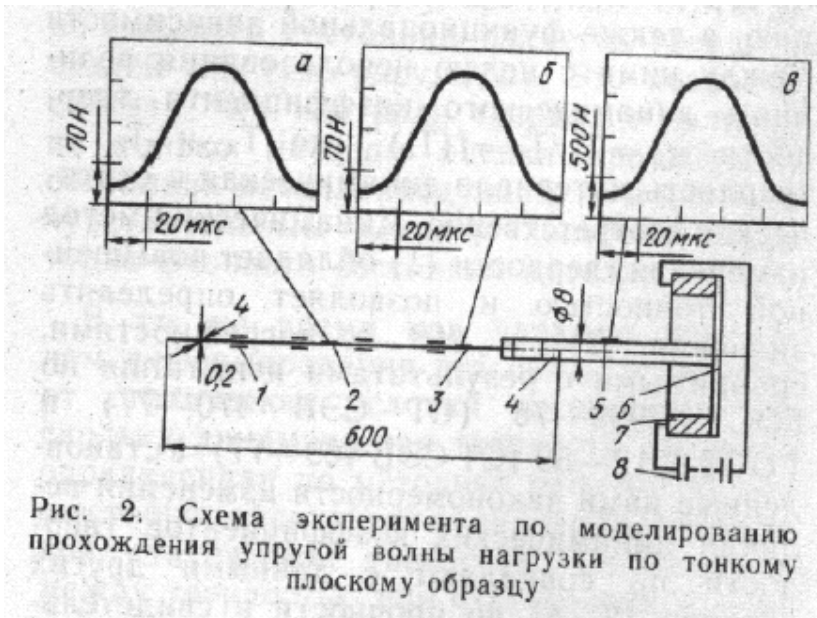
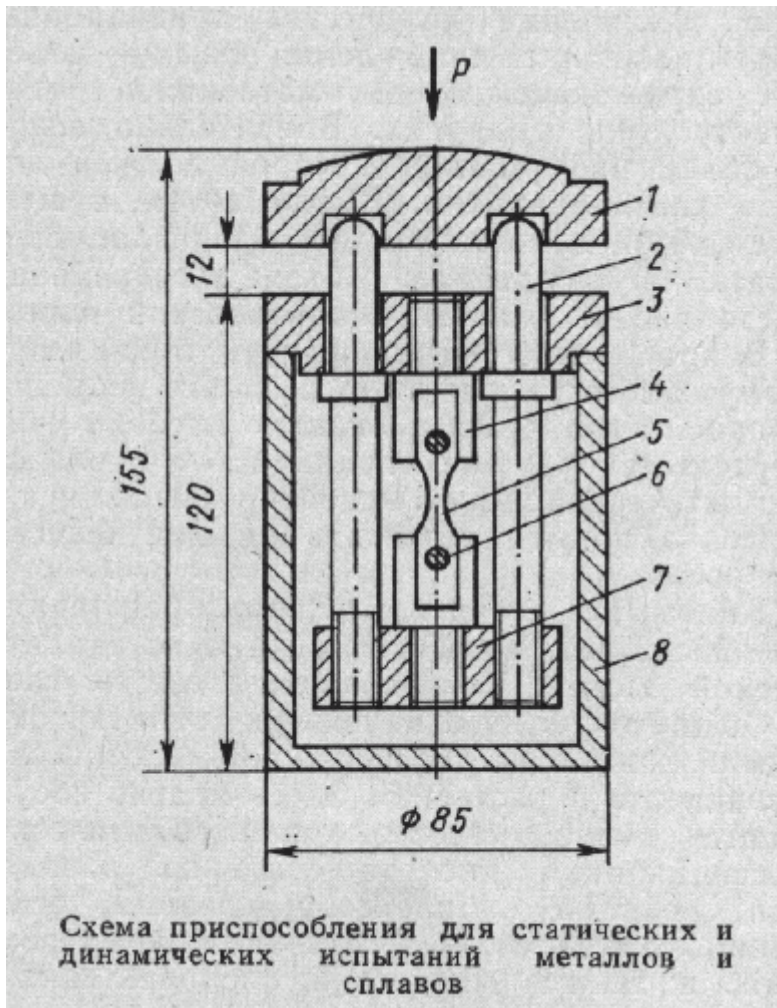


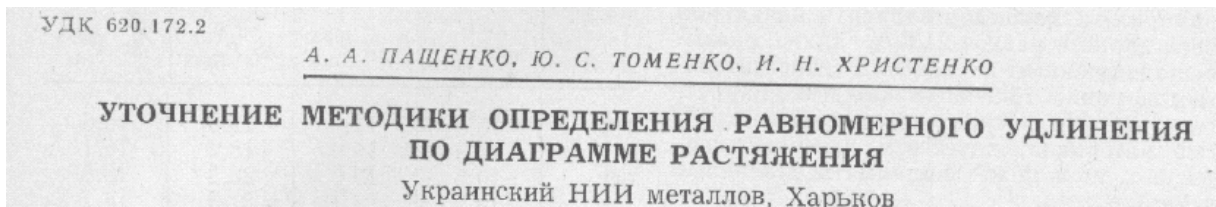
Рис. 2. Схема эксперимента по моделированию прохождения упругой волны нагрузки по тонкому плоскому образцу

Fig.2. Experiment, which models progress of the elastic wave through the sample.

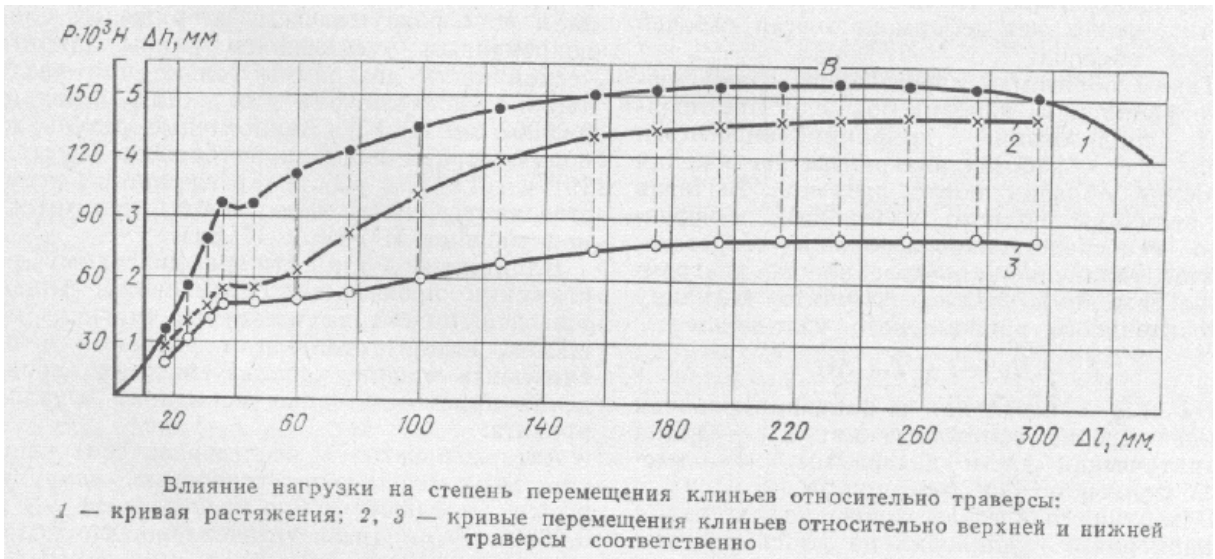
**ПРИСПОСОБЛЕНИЕ ДЛЯ СТАТИЧЕСКИХ И ДИНАМИЧЕСКИХ ИСПЫТАНИЙ МЕТАЛЛОВ
НА РАСТЯЖЕНИЕ ПРИ ТЕМПЕРАТУРАХ ОТ +80 ДО -196 °С**



Przedstawiony schemat badań pozwala na prowadzenie rozciąganie w zakresie temperatur od -196 do $+80$ °C. Płaskie próbki o zmiennej powierzchni przekroju są mocowane w tym przyrządzie a następnie podgrzewane albo chłodzone razem. Po osiągnięciu zadanej temperatury przyrząd jest transportowany pod prasę i prowadzone badania. Dzięki zmiennej geometrii próbki i wcześniej naniesionych na osi próbki odcisków dla badania zmiany deformacji w próbce.



Pokazano, że nieuwzględnienie odkształcenia i przemieszczenie uchwytów może doprowadzić do błędnych pomiarów wydłużenia. Dla tego polecane jest korekcja wyników z uwzględnieniem przemieszczeń uchwytów podczas rozciągania płaskich próbek.



Appendix 3: Precision of Tensile Testing and Estimation of Uncertainty of Measurement.

.....

EN 10002 Part1 : Metallic Materials - Tensile Testing at Ambient Temperature

Precision of Tensile Testing and Estimation of the Uncertainty of Measurement

A1. Introduction

This annex gives guidance of how to estimate the uncertainty of the measurements undertaken in accordance with this standard using a material with known tensile properties. It should be noted that it is not possible to give an absolute statement of uncertainty for this test method because there are both **material dependent** and **material independent** contributions to the uncertainty statement. Hence it is necessary to have a prior knowledge of a material's tensile response to straining or stressing rate before being able to calculate the measurement uncertainty.

An approach for estimating the uncertainty of measurement using the "error budget" concept based upon the tolerances specified in the testing and calibration standards has been presented elsewhere (Loveday, 1992) and was subsequently expanded to form the basis of the informative annex for ISO 6892 (1995). This annex has now been revised to follow more closely the approach for estimating the uncertainty of measurement outlined in the ISO TAG 4 'Guide to the expression of uncertainty in measurement.' (1994).

The precision of the test results from a tensile test is dependent upon factors related to the material being tested, the test piece geometry and machining, the testing machine, the test procedure and the methods used to calculate the specified material properties. Ideally all the following factors should be considered:

- measurement of the testpiece dimensions, gauge-length marking, extensometer gauge-length
- measurement of force and extension
- test temperature and loading rates in the successive stages of the test,
- the method of gripping the testpiece and the axiality of the application of the force
- the testing machine characteristics (stiffness, drive, control and method of operation)
- human and software errors associated with the determination of the tensile properties

- the material inhomogeneity which exists even within a single processed batch obtained from a single melt of material.

In practice the requirements and tolerances of the present standard do not allow all the effects to be quantified. However interlaboratory tests may be used to determine the overall uncertainty of results under conditions close to those used at industrial laboratories, but such tests do not separate effects related to the material inhomogeneity from those attributable to the testing method.

It should be appreciated that it is not possible to calculate a single value for the measurement uncertainty for all materials since different materials exhibit different response characteristics to some of the specified control parameters, eg straining rate or stressing rate (Loveday 1992). The uncertainty budget presented here could be regarded as an upper bound to the measurement uncertainty for a laboratory undertaking testing in compliance with EN 10002 Pt1 since it is possible that a laboratory could actually control some of the testing parameters to a better level of precision than that demanded by the standard, eg the force might be measured to $\pm 0.5\%$ (ie, a Class 0.5 machine) whereas the testing standard EN 10002 Pt1 only requires that the force shall be measured to better than $\pm 1\%$. Alternatively, the actual value of the Uncertainty of the Force Measurement system, determined during the verification of the machine in accordance Annex D of ISO 7500 Pt1, could be used in the uncertainty budget.

It should be noted that when evaluating the total scatter in experimental results the uncertainty in measurement should be considered in addition to the inherent scatter due to material inhomogeneity. A statistical approach to the analysis of intercomparison exercises ('Round Robin' experiments) does not separate out the two contributing causes of the scatter, but never the less gives a useful indication of the likely range of tensile results measured by different laboratories using similar material. Typical results from various inter-comparison exercises are given in Section A5.

A2. An Overview of Uncertainty Estimation Based Upon the GUM

The: "**Guide to the expression of uncertainty in measurement**", was published jointly by several authoritative standards bodies, namely BIPM, IEC, IFCC, ISO, IUPAC, IUPAP and OIML which will be referred to hereafter as GUM (Guide to Uncertainty in Measurement). It is a comprehensive document of over 90 pages based upon rigorous statistical methods for the summation of uncertainties from various sources. Its complexity has provided the driving force for a number of organisations to produce simplified versions of the GUM, eg the National Institute of Science and Technology (NIST) in the USA (Taylor and Kuyatt), the National Measurement Accreditation Service (NAMAS) in the UK (NIS 80 and NIS 3003). These various documents all give guidance of how to estimate uncertainty of measurement based upon an "uncertainty budget" concept.

The total uncertainty of a measurement is determined by summing all the contributing components in an appropriate manner. It is necessary to quantify all the contributions, and at the preliminary evaluation stage to decide whether some contributions are negligible and therefore not worth including in the subsequent calculations. For most practical measurements, in the materials field the definition of negligible may be taken as a component smaller than one-fifth of the largest component. The GUM categorises two ways of evaluating uncertainties, A and B. Type A determinations is by repeat observations and provided sufficient readings are available, say greater than 9, then conventional statistical analysis can be used to determine the standard deviation $s(q_k)$.

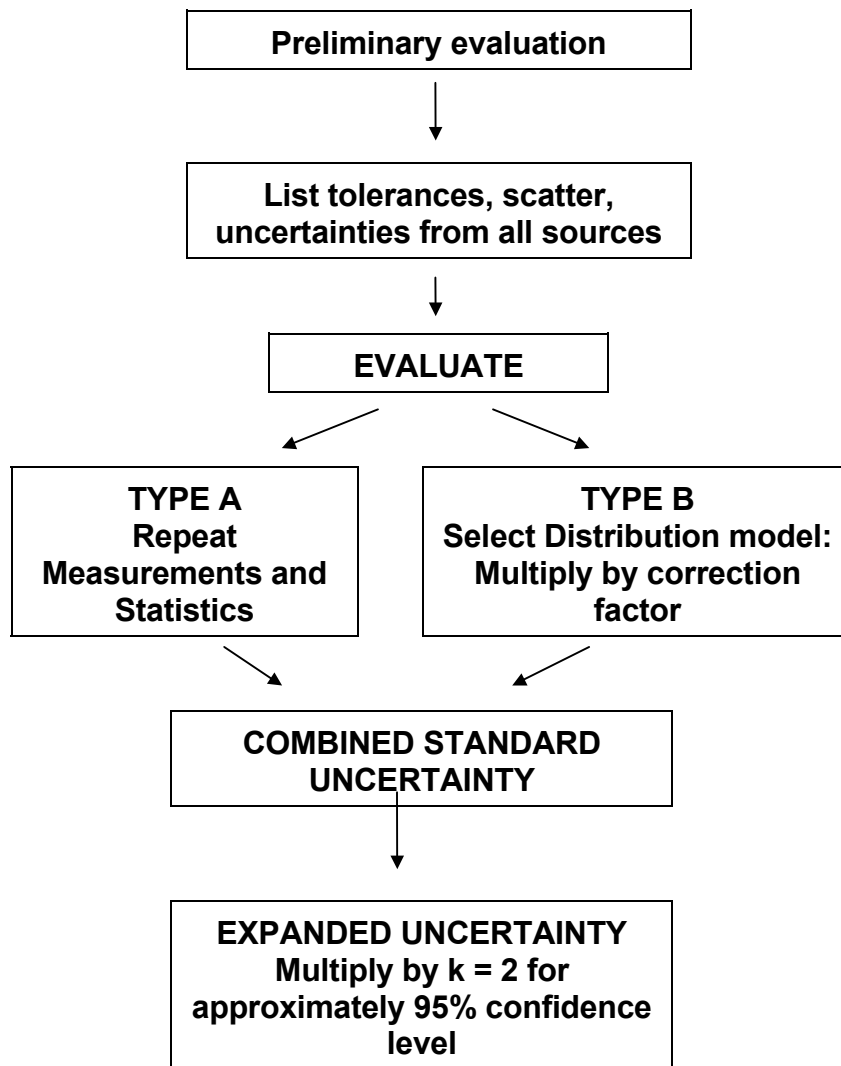


Table A1. GUM: Outline of Procedure for Estimation of Uncertainty

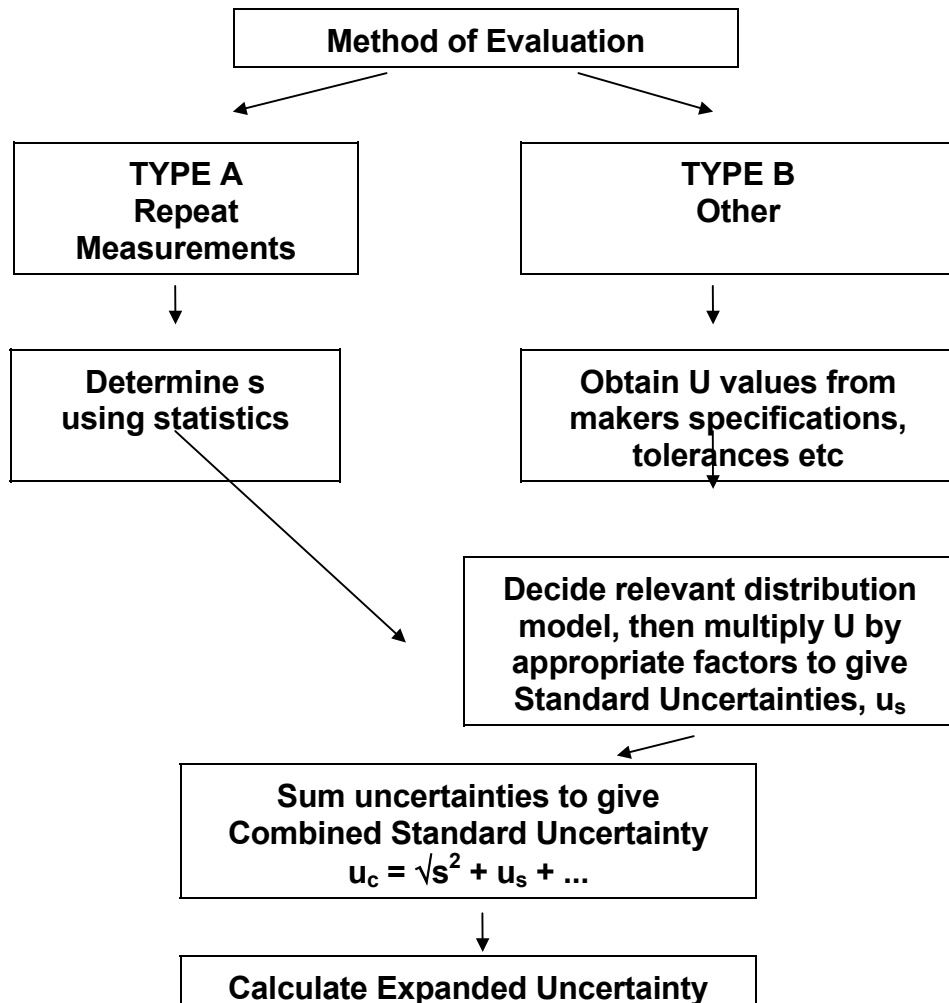
Type B evaluation is by means other than Type A and makes use of, for example, tolerances specified in standards, measured data, manufacturers

specifications, calibration certificates and in most cases a knowledge of a simple model of the relationship between the various components, and of the likely distribution model of the components. If for example the tolerance specified in a Standard is $\pm a$, then in absence of any other knowledge, it may be appropriate to assume a rectangular distribution model in which case, the uncertainty becomes

$$u_s = \frac{a}{\sqrt{3}}$$

If better knowledge is available it may be that a triangular distribution would be more appropriate, then $u_s = \frac{a}{\sqrt{2}}$, (see GUM), where u_s denotes a **Standard**

Uncertainty obtained by multiplying U by an appropriate factor. The next step is to determine the **Combined Standard Uncertainty**, u_c by summing the standard uncertainties, usually by using the root sum square method. The **Expanded Uncertainty** U_E , is then obtained by multiplying u_c by a coverage factor, k , where $k = 2$ for approximately 95% confidence level, thus, $U_E = 2u_c$; this procedure is shown schematically in Table A2.



$$U_E = k \cdot u_c$$

(k = 2 for approximately 95% confidence level)

Table A2 Procedure for estimating uncertainty in accordance with the GUM

K3 Tensile Testing : Uncertainty Estimation

K3.3 Material Independent Parameters.

The tolerances for the various testing parameters for tensile properties specified in EN 10002 Pt1. are given in Table A3. Because of the shape of the stress-strain curve, some of the tensile properties in principle can be determined with a higher degree of precision than others, eg, the upper yield stress, R_{eh} is only dependent on the tolerances for measurement of force and cross sectional area, whilst proof stress, R_p , is dependent on force, strain (displacement), gauge length and cross-sectional area. In the case of reduction in area, Z, the measurement tolerance for cross sectional area both before and after fracture need to be considered.

Parameter	Tensile Properties, % Error					
	R_{eh}	R_{eL}	R_m	R_p	A	Z
Force	1	1	1	1	-	-
Strain * (Displacement)	-	-	-	1	1	-
Gauge * Length, L_0	-	-	-	1	1	-
S_o	1	1	1	1	-	1
S_u	-	-	-	-	-	2

* Assuming a Class 1 extensometer calibrated in accordance with EN 10002 Part 4.

Table K3. Measurement uncertainty for tensile testing based upon material independent parameters, using tolerances specified in EN 10002 Part 1.

In the GUM two types of uncertainty are categorised. Type A and B. A type A evaluation of uncertainty may be based on any valid statistical method for treating data. A type B evaluation is based on some other means thus the use of tolerances specified in a standard comes under the type B category. The tolerances shown above for tensile testing represent maximum bound values, ie all the values must lie within the specified tolerance viz, $a = \pm 1\%$, and thus the model distribution corresponds to a rectangular

probability distribution specified in the GUM, hence the standard uncertainty values for the individual parameters are given by $a/\sqrt{3}$. To fully comply with the assessment of uncertainty it would be necessary to consider all the possible sources of uncertainty contributing to the measurements including those due to uncertainties in the devices used in the calibration chain, ie the force proving devices and the extensometer calibrators. In practice, such sources of error are second order effects and for the purposes of this paper a simplified approach will be adopted using the concepts outlined in the GUM. This the combined uncertainty of the material independent parameters for R_{eh} , R_{eL} , R_m and A is $\sqrt{0.33 + 0.33} = \pm 0.81\%$, and for R_p is $\sqrt{0.33 + 0.33 + 0.33 + 0.33} = \pm 1.15\%$; using a root mean-squares summation approach.

A3.2. Material Dependent Parameters

For room temperature tensile testing the only tensile properties significantly dependent upon the materials response to the straining-rate (or stressing-rate) control parameters are R_{eh} , R_{eL} and R_p . Tensile strength, R_m , can also be strain rate dependent, however in practice it is usually determined at a much higher straining-rate than R_p and is generally relatively insensitive to variations in the rapid strain-rates.

In principle it will be necessary to determine any materials strain rate response before the total error budget can be calculated. Some limited data is available and the following examples may be used to estimate uncertainty for some classes of materials.

A typical example of data set used to determine materials response over the strain rate range specified in EN10002 Pt1 is shown in Figure A1 and a summary of materials response for proof stress for a number of materials measured under strain rate control is given in Table A4. Earlier data on a variety of steels measured under a set stressing rate are given in the seminal paper by Johnson and Murray (1966).

Since the equivalent tolerances, a , are based on measured data, using a simple least mean squares fit to the data, it is necessary to decide what distribution model of the uncertainties is appropriate in accordance with the GUM. If it is assumed that the model is a normal distribution with upper and lower limits $+a$ and $-a$, such that the best estimate of the quantity is $(a_+ + a_-)/2$ and that there is a 2 out of 3 chance (ie a 67% probability) that the value of the quantity lies in the interval a_- to a_+ , then the uncertainty $U = a$. [Note: if it was assumed that the probability was 50%, then $u = 1.48a$] (See Taylor and Kuyatt, 1993).

Material	Nominal Composition	R _{P0.2} MPa	Proof Stress/ Strain-Rate Variation %	Equivalent Tolerance ± %
<u>Ferritic Steel</u> Pipe steel	Cr-Mo-V-Fe(bal)	680	0.1	0.05
Plate steel (BS 4360 Grade 43E)	C-Mn-Fe (bal)	315	1.8	0.9
<u>Austenitic Steel</u> 316 Stainless	17 Cr; 11 Ni-Fe (bal)	235	6.8	3.4
<u>Nickel Base Alloys</u>				
Nimonic 75	18 Cr, 5 Fe, 2 Co-Ni (bal)	325	2.8	1.4
Nimonic 101	24 Cr, 20 Co, 3 Ti, 1.5 Mo, 1.5 Al-Ni(bal).	790	1.9	0.95

Table A4. Variation in room temperature proof stress over the strain rate range permitted in EN10002 Pt1.

K3.3 Combined standard measured uncertainty

The material dependent response of proof stress over the permitted strain rate range specified in the standard given in Table K4 may be combined with the standard uncertainties derived from material independent parameters specified in Table K3 to give the Combined Uncertainty, u_C for the various materials indicated, as shown in Table A5.

For the purpose of this analysis the total value of the variation in proof stress over the strain-rate range permitted in the standard has been halved and expressed as an equivalent tolerance, ie for 316 stainless steel, the proof stress can vary by 6.8% over the permitted strain-rate range so it is equivalent to a tolerance of ± 3.4%, which should be divided by $\sqrt{3}$, ie 1.963 and then added to the combined uncertainty of the material independent parameters using the root mean square method. Therefore for 316 stainless steel the combined standard uncertainty is given by:

$$\pm \sqrt{1.15^2 + 1.96^2} = \pm \sqrt{5.17} = \pm 2.3\% \quad (2)$$

<u>Material</u>	Standard uncertainty from material independent parameters ± %	Material Dependent Standard Uncertainty ± %	Combined Standard Uncertainty ± %	Expanded Uncertainties at 95% Confidence ±%
<u>Ferritic Steel</u>				
Pipe steel	1.15	0.03	$\sqrt{1.33} = 1.15$	2.3
Plate steel	1.15	0.52	$\sqrt{1.59} = 1.26$	2.5
<u>Austenitic Steel</u>				
316 Stainless	1.15	1.96	$\sqrt{5.17} = 2.3$	4.6
<u>Nickel Base Alloys</u>				
Nimonic 75	1.15	0.81	$\sqrt{1.98} = 1.41$	2.8
Nimonic 101	1.15	0.55	$\sqrt{1.63} = 1.28$	2.7

Table A5. Combined standard measurement uncertainty for room temperature proof stress determined in accordance with En 10002 Pt1.

A3.4 Expanded Uncertainty

In accordance with the ISO TAG 4 Guide, the total Expanded Uncertainties are obtained by multiplying the Combined Standard Uncertainties by a coverage function, k . For approximately 95% level of confidence, $k=2$ and the corresponding Expanded Uncertainties are also listed in Table A5.

A4. Discussion

A method of calculating the measurement uncertainty for room temperature tensile testing using an "Uncertainty Budget" concept has been outlined and examples given for a few materials where the material response to the testing parameters is known. It should be noted that the Expanded Uncertainties have been calculated using a simplified approach based on the GUM. In addition there are other factors that can affect the measurement of tensile properties such as testpiece bending, methods of gripping the testpiece, or the testing machine control mode, i.e. extensometer control or load/crosshead control which may affect the measured tensile properties, (Gray and Sharp, 1988), however since there is insufficient quantitative data available it is not possible to include their effects in error budgets at present. It should also be recognised that this uncertainty budget approach only gives an estimate of the uncertainty due to the measurement technique and does not make an allowance for the inherent scatter in experimental results attributable to material inhomogeneity.

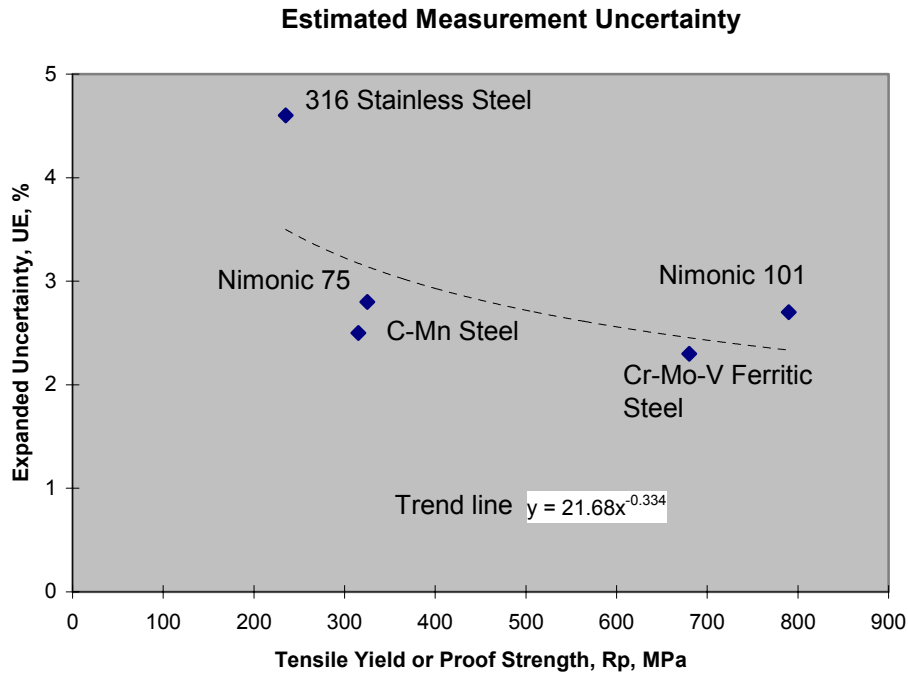
An indication of the scatter in experimental results attributable to inhomogeneity in material i.e. **material scatter** may be determined by undertaking repeat testing on the same testing machine, under the identical testing conditions, ie same operator, same strain-rate etc., thereby determining the **repeatability**. An example of such data for Nimonic 75, which is now available as a Certified Reference Material for Room Temperature Tensile Testing, CRM661*, is given in Table K6 where it can be seen that the repeatability for the 0.2% room temperature proof stress is $\pm 2.5\%$ with approximately 95% confidence limit. The standard deviation[†] is $\pm 1.25\%$ and this may be added to the combined measurement uncertainty ($\pm 3.6\%$, see Table K3) using the least mean squares approach and multiplying by $K = 2$ to give the total Expanded Uncertainty at approximately the 95% confidence level, i.e.

Total Expanded Uncertainty = $2\sqrt{[(3.6)^2 + (1.25)^2]} = \pm 3.8\%$.

This implies that differences of up to 7.6% between two laboratories measuring the proof stress of Nimonic 75, should not be regarded as being statistically significant at the 95% confidence level, assuming that both laboratories are able to demonstrate repeatability of $\pm 2.5\%$, and both are undertaking the measurements within the tolerances specified in the testing standard.

* Available from the Institute for Reference Materials and Measurements, (IRMM), Joint Research Centre, Retieseweg, B 2440, Geel, Belgium.

+ Note: The full value of the standard deviation is used since in the case of a destructive test as performed on a tensile testpiece, $n = 1$, hence the standard deviation of the mean is given by s/\sqrt{n} .



Expanded Measurement Uncertainties at the 95% confidence level for Proof or Yield Strengths selected materials tested in accordance with EN 10002 Part 1.

Values of Reproducibility from Laboratory Inter-Comparison Exercises.

Testpiece number	$R_{P0.2}$ MPa
GAN 96	315.3
97	313.9
99	313.1
100	316.1
122	304.3
124	310.0
127	315.0
128	319.3
129	311.7
142	318.5
143	314.4
150	316.0
n = 12	$\bar{q} = 314.0$ s = 4.0
Repeatability = $\frac{2s}{\bar{q}} \times 100 = \frac{8}{314} \times 100 = \pm 2.5\%$ (95% Confidence)	

Table A6. Room temperature 0.2% Proof stress data, $R_{P0.2}$, for Nimonic 75 measured at a strain rate of $2 \times 10^{-3} \text{ min}^{-1}$.

A 6. References.

Standards.

ISO (TAG4) (1993) 'Guide to the expression of uncertainty
: in measurement.' BIMP/IEC/IFCC/ISO/ IUPAC/IUPAP/OIML

ISO 5725: Accuracy (trueness and precision) of measurement methods and results. Part 1 General principle and definitions.

Papers.

CAMPION, P.J., BURNS, J.E and WILLIAMS, A (1980). "A Code of Practice for the detailed statement of accuracy" Pub. National Physical Laboratory, ISBN 0 950 4496 6 0.

GRAY, T.G.F and SHARP, J. (1988). "Influence of machine type and strain-rate interaction in tensile testing" ASTM Symposium on Precision of Mechanical Tests, STP 1025.

JOHNSON, R.F and MURRAY, J.D. (1966). "The effect of rate of straining on the 0.2% proof stress and lower yield stress of steel", Symposium on High Temperature Performance of Steels", Eastbourne 1966, Pub. Iron & Steel Institute, 1967.

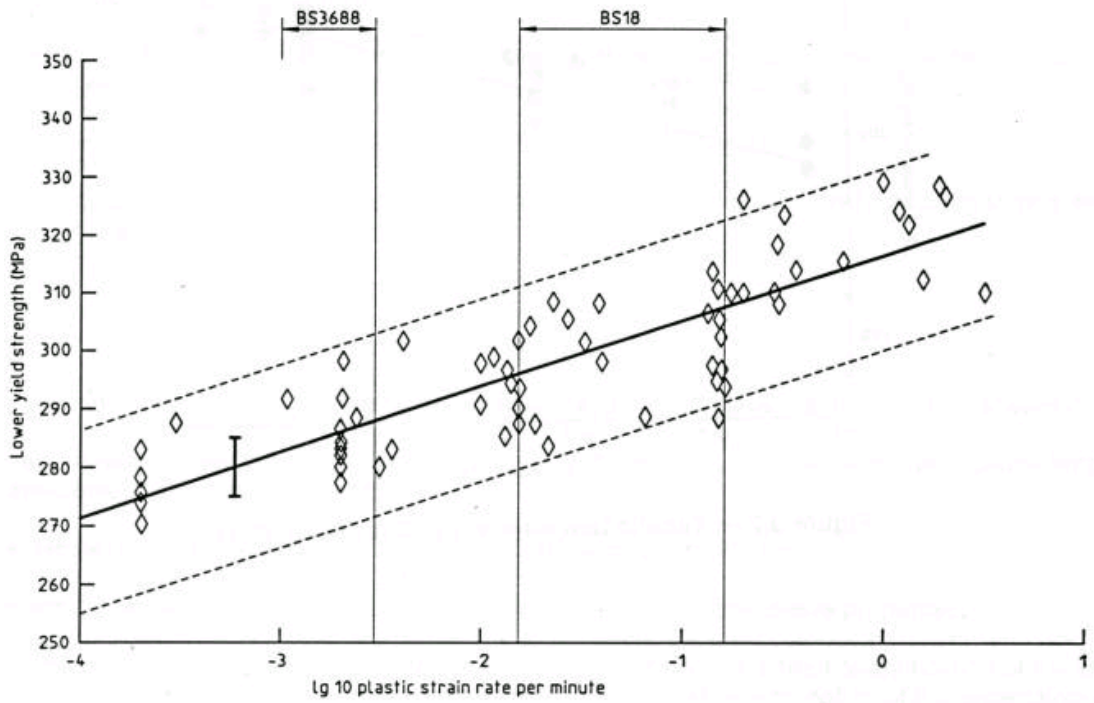
LOVEDAY, M.S. (1992). "Towards a tensile reference material", Chapter 7, 111-153 in 'Harmonisation of Testing Practice for High Temperature Materials', Ed M S Loveday and T B Gibbons. Pub. Kluwer (formerly published by Elsevier Applied Science).

INGELBRECHT, C & LOVEDAY, M.S. (2000) *'The Certification of Ambient Temperature Tensile Properties of a Reference Material for Tensile Testing According to EN 10002-1.'*, EU Report 19589 EN.

NIS 80. (1994) ."Guide to the expression of uncertainty in testing". Pub. NAMAS,UK.

NIS 3003 (1995). The Expression of Uncertainty and Confidence in Measurement. Pub. NAMAS., UK.

TAYLOR, B.N and KUYATT, C.E (1993). Guidelines for Evaluating and Expressing the Uncertainty of NIST Measurement Results. NIST Technical Note 1297.



Key
 | Maximum expected error in stress

Figure J.1 — Variation of lower yield strength (R_{eL}) at room temperature as a function of strain rate, for plate steel [6]

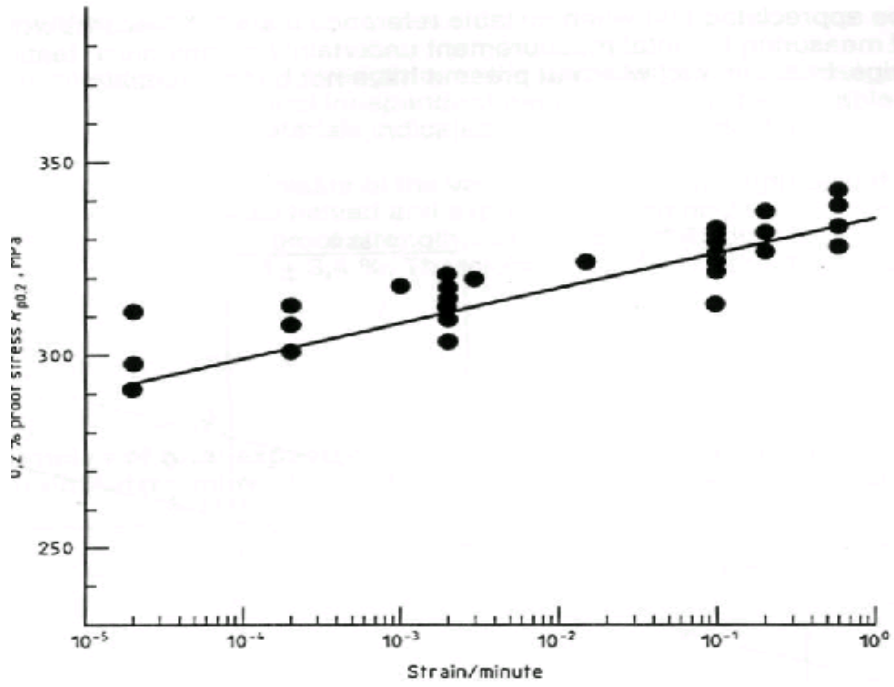


Figure J.2 — Tensile test data at 22 °C for Ni Cr 20 Ti