

Engineering Considerations of a Portable Neutron Spectrometer



Bob D'Mellow
Department of Engineering
Lancaster University

Introduction

- ◆ Background
 - ◆ TNS
 - ◆ APNS
- ◆ Engineering considerations
 - ◆ Mass and size
 - ◆ Processing power
 - ◆ Maintenance
- ◆ Summary

Background - TNS

- ◆ Transportable Neutron Spectrometer
 - ◆ AEA Winfrith around 1980
 - ◆ Covers energy range from thermal to 10MeV
 - ◆ BF_3 bare, BF_3 Cd covered, 1, 3, 10 atm. H_2 filled SP2 and 3.5cc NE213
 - ◆ Four units total 75kg
 - ◆ Unfolding with RADAK



Background - APNS

- ◆ Advanced Portable Neutron Spectrometer
 - ◆ Updated version of TNS
 - ◆ Lighter and truly portable
 - ◆ Covers same energy range
 - ◆ Emphasis on digital processing techniques

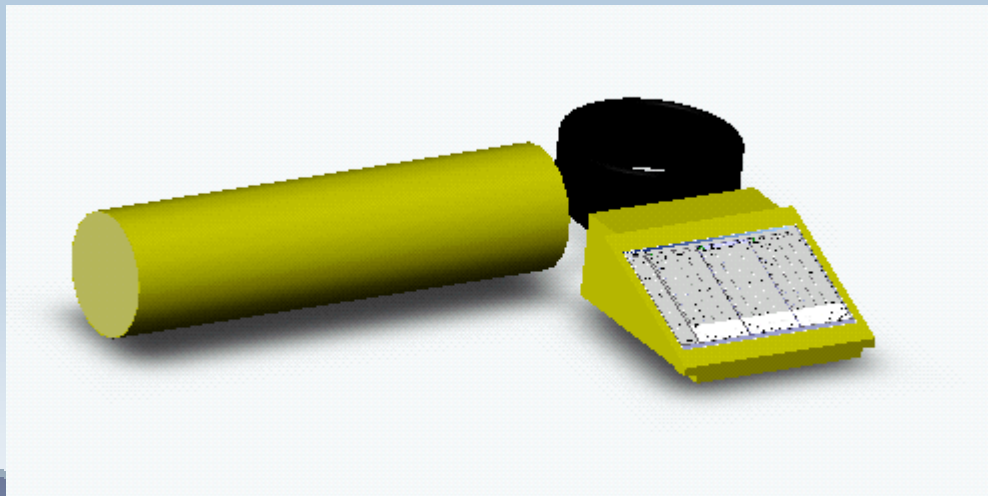

Size and Mass

- ▶ Probe casing
 - ▶ 2mm thick aluminium
 - ▶ Same size as TNS
- ▶ Electronics more integrated
- ▶ Internal support structures minimised

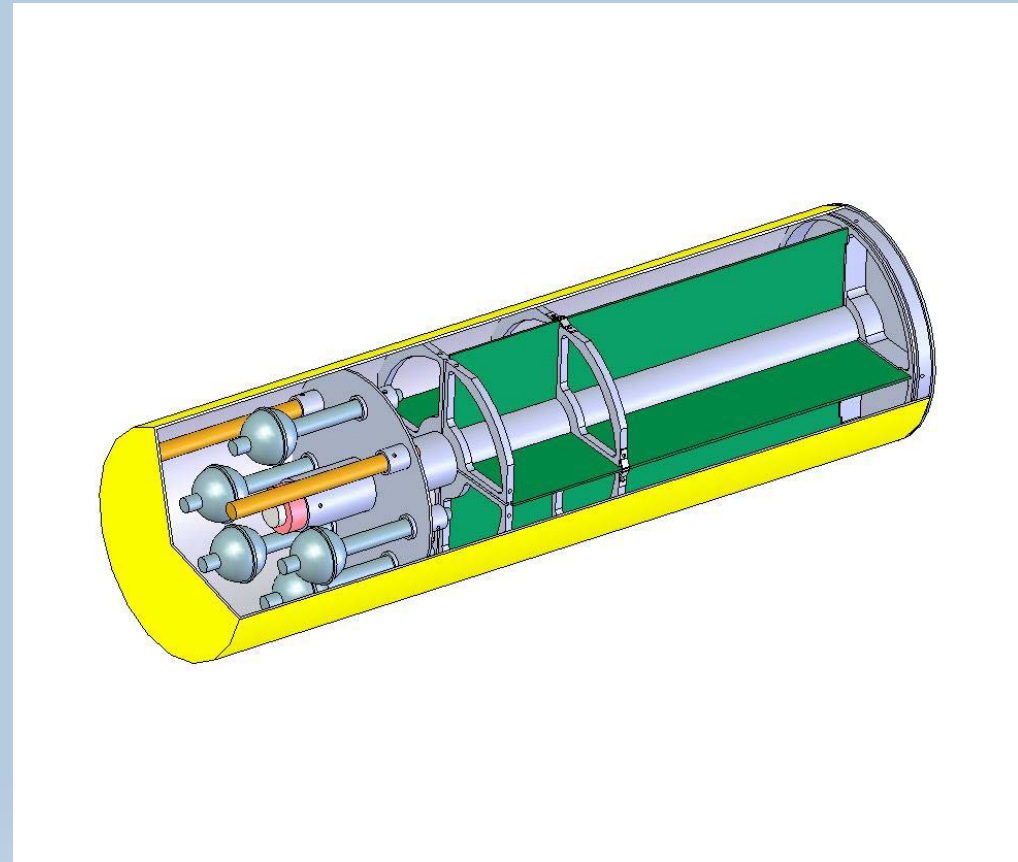

Electronics

- ◆ Design rationale – digitise as early as practical
 - ◆ Less component drift
 - ◆ Less sensitive to noise
 - ◆ More compact
 - ◆ Better data transmission
- ◆ But
 - ◆ Slower processing
 - ◆ Quantisation errors

Maintenance

- Digital processing allows modification of processing algorithm without major design change
- Front end controls implemented on touch screen for flexible configuration
- Digital data transmission between units
- Ease of access to internals
- Software based maintenance manuals on machine

Summary

- ◆ Technology advancements
 - ◆ Faster digital processing
 - ◆ Cheaper specialist computing ICs
 - ◆ Smaller and lower power components
- ◆ Acknowledgements
 - ◆ Dr. Malcolm Joyce – Lancaster University
 - ◆ BAE SYSTEMS - Barrow