

Response characteristics of neutron survey instruments

Rick Tanner and David Bartlett, NRPB
Hamid Tagziria and David Thomas, NPL

**DTI National Measurement System Policy Unit
Project 3.6.1**

**Provision of reliable energy response
function data for routinely used survey
meters in neutron metrology**

NMSPU Reference MPU 8/56.4

Objectives

- Ascertain the types and numbers of instrument in use in the UK
- Gather together experimental response data for those instruments
- Generate new response data for the most commonly used instruments using MCNP™
- Compare calculated with experimental data to produce a unified data set for the instruments' response characteristics

Introduction: survey instruments

- Area survey instruments used to determine the dose rate in areas where personnel may be occupationally exposed
- Most survey instruments in use in the UK are of designs which originate in the 1960's
- Small changes to the designs have been made at regular intervals
- Many response measurements have been made, but no definitive sets exist for these instruments
- Response characteristics relatively poorly characterized

Neutron area survey instruments

- For sensitivity reasons they generally rely on capture reactions: e.g. $^{10}\text{B}(n, \alpha)^7\text{Li}$ or $^3\text{He}(n, p)^3\text{H}$
- Thermalize the neutron field using large mass of hydrogenous material
- Correct the over-response to intermediate energy neutrons via an absorbing layer (e.g. boron or cadmium) in the moderator
- Prevent an over-suppression of the thermal neutron response via holes in the absorbing layer
- More sophisticated designs not in widespread use

Useful cross sections

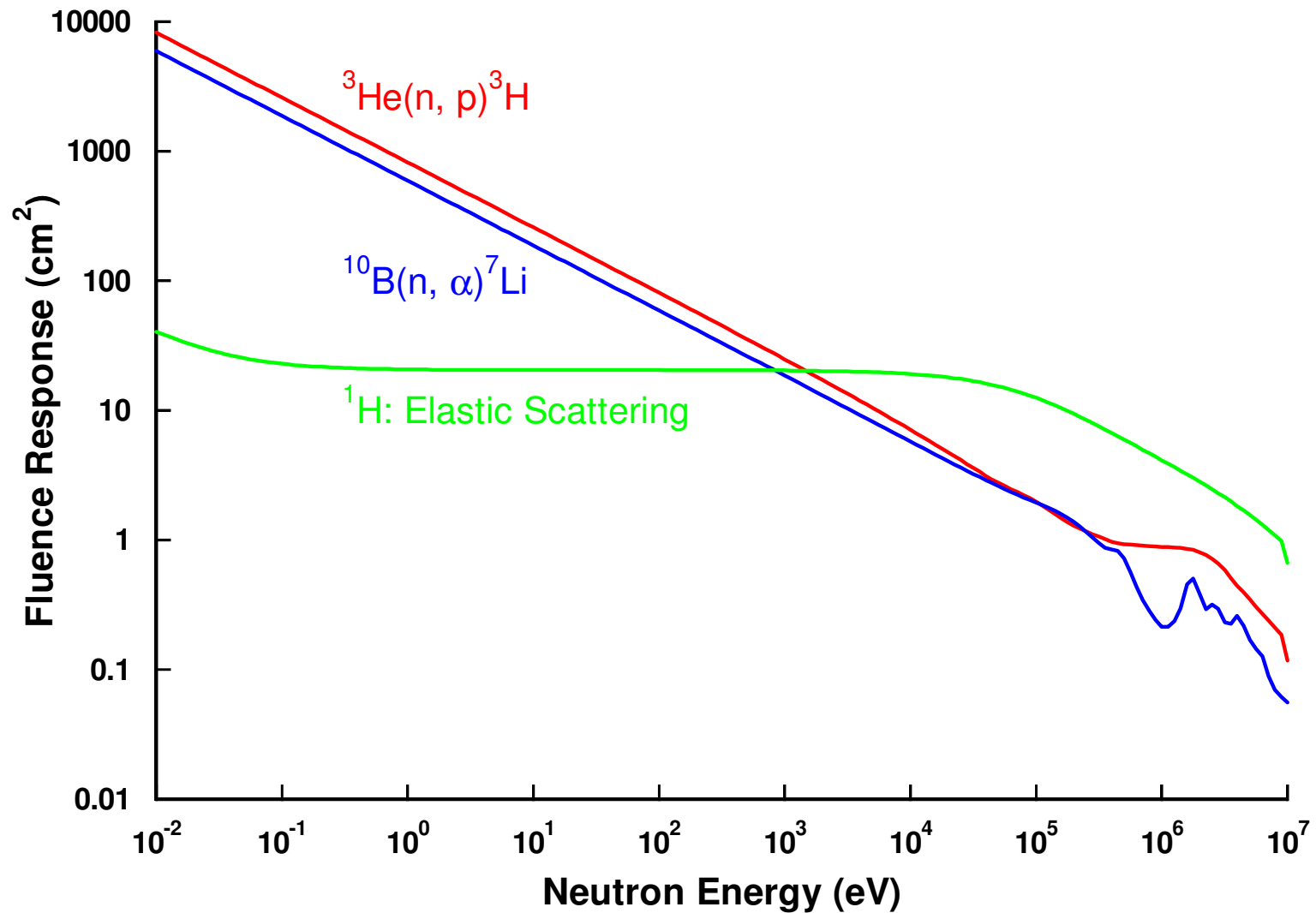

Cross sections & workplace fields

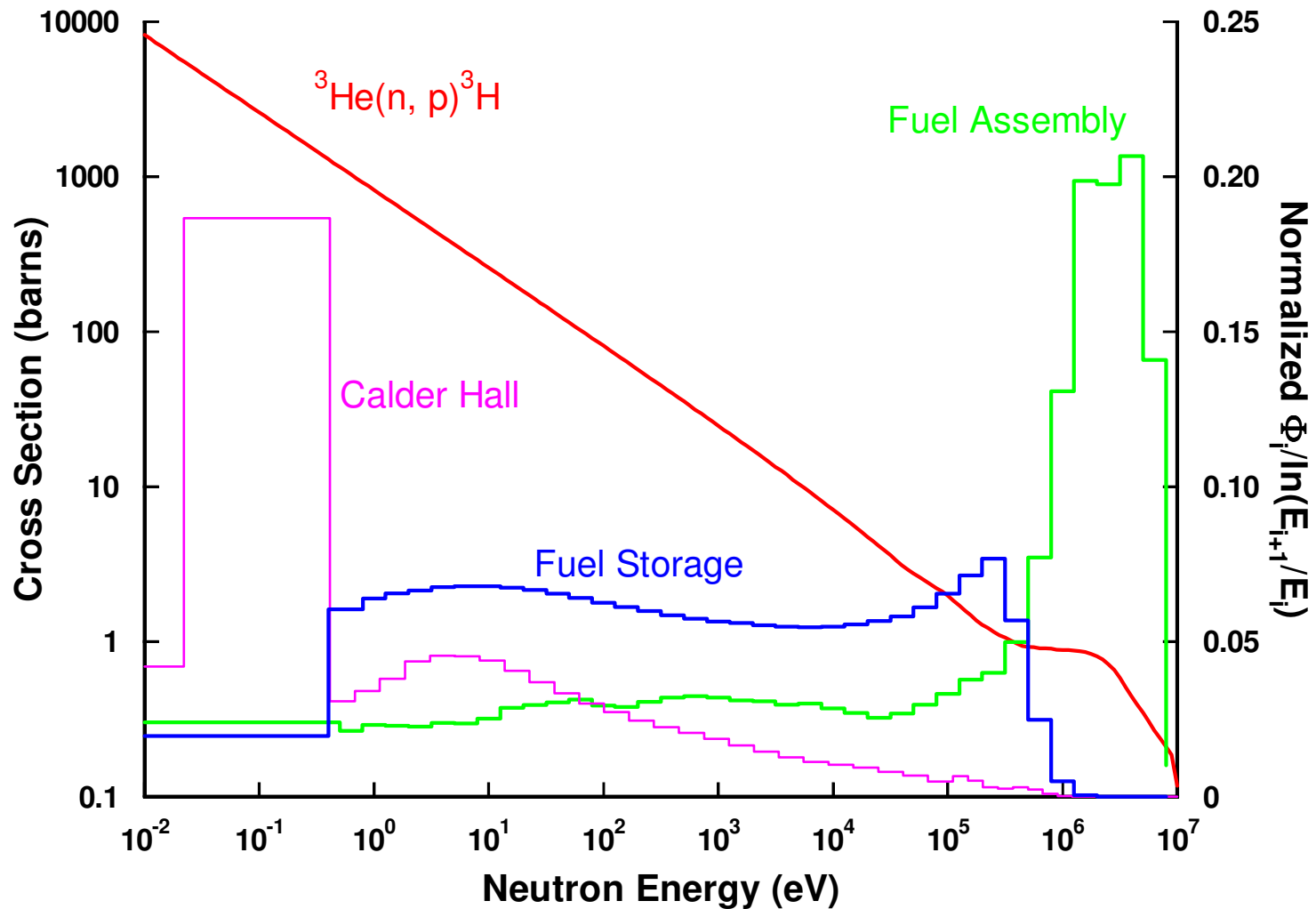

Andersson-Braun design

- Seminal work by Andersson-Braun in 1963 produced a practical survey instrument
- Central thermal neutron detector (BF_3 tube)
- CH_2 moderating mass (cylindrical symmetry)
- Perforated boron loaded layer
- Heavy with approximately dose equivalent response
- Over-responds in the intermediate energy region

Leake design

- Paper on a spherical design of neutron survey instrument published by Leake in 1966
- Central spherical ^3He thermal neutron detector
- Spherical CH_2 moderating mass
- Perforated cadmium layer in the moderator
- Slightly lighter with approximately dose equivalent response
- Over-responds to intermediate energy neutrons

Survey of UK instrument usage

Surveyed large users and calibration laboratories

Type	Number
Leake	325 (57%)
NM1/2	118 (21%)
Studsvik 2202/2222	60 (11%)
9" sphere	50 (9%)

H*(10) response

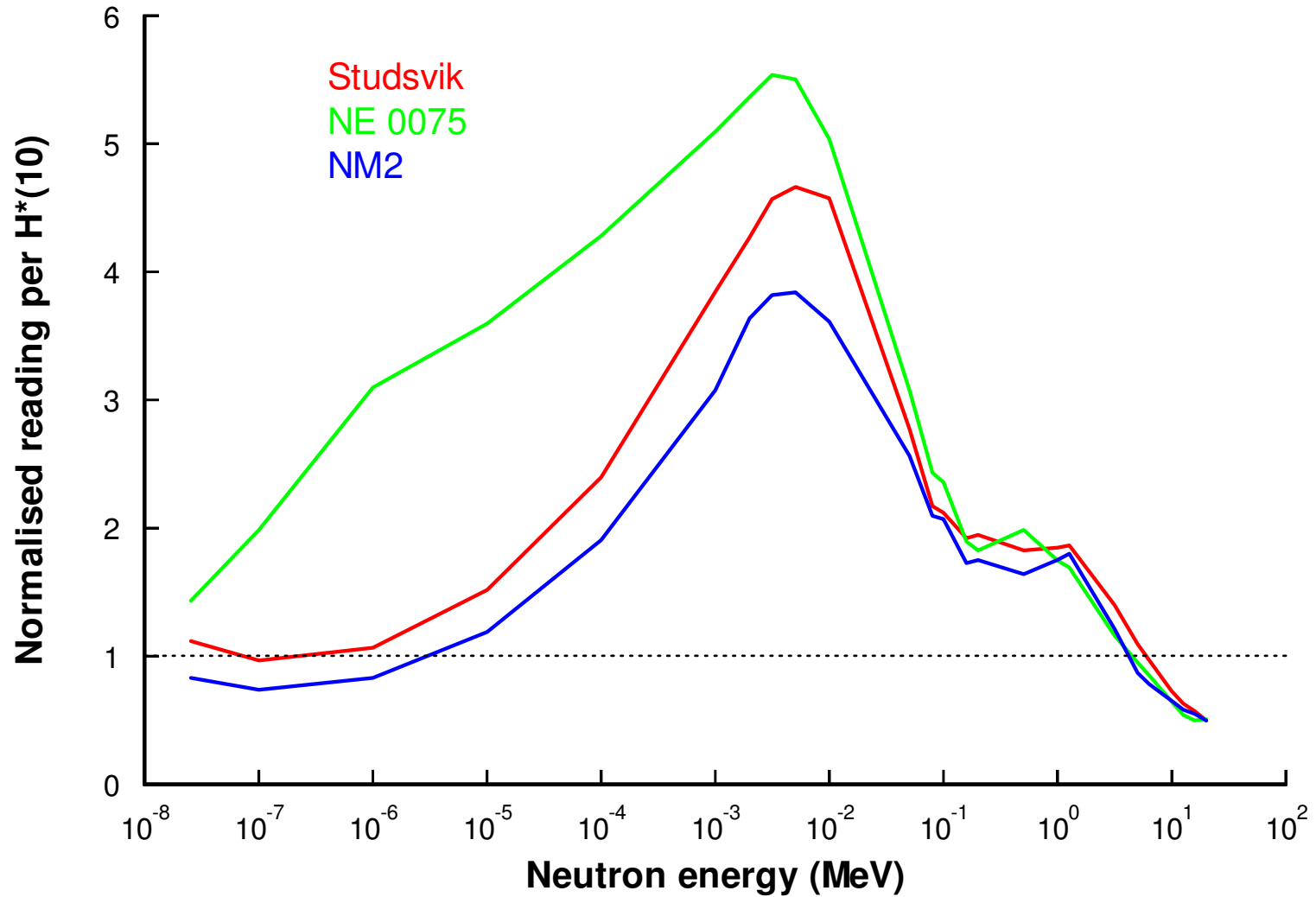

H*(10) response and workplace fields

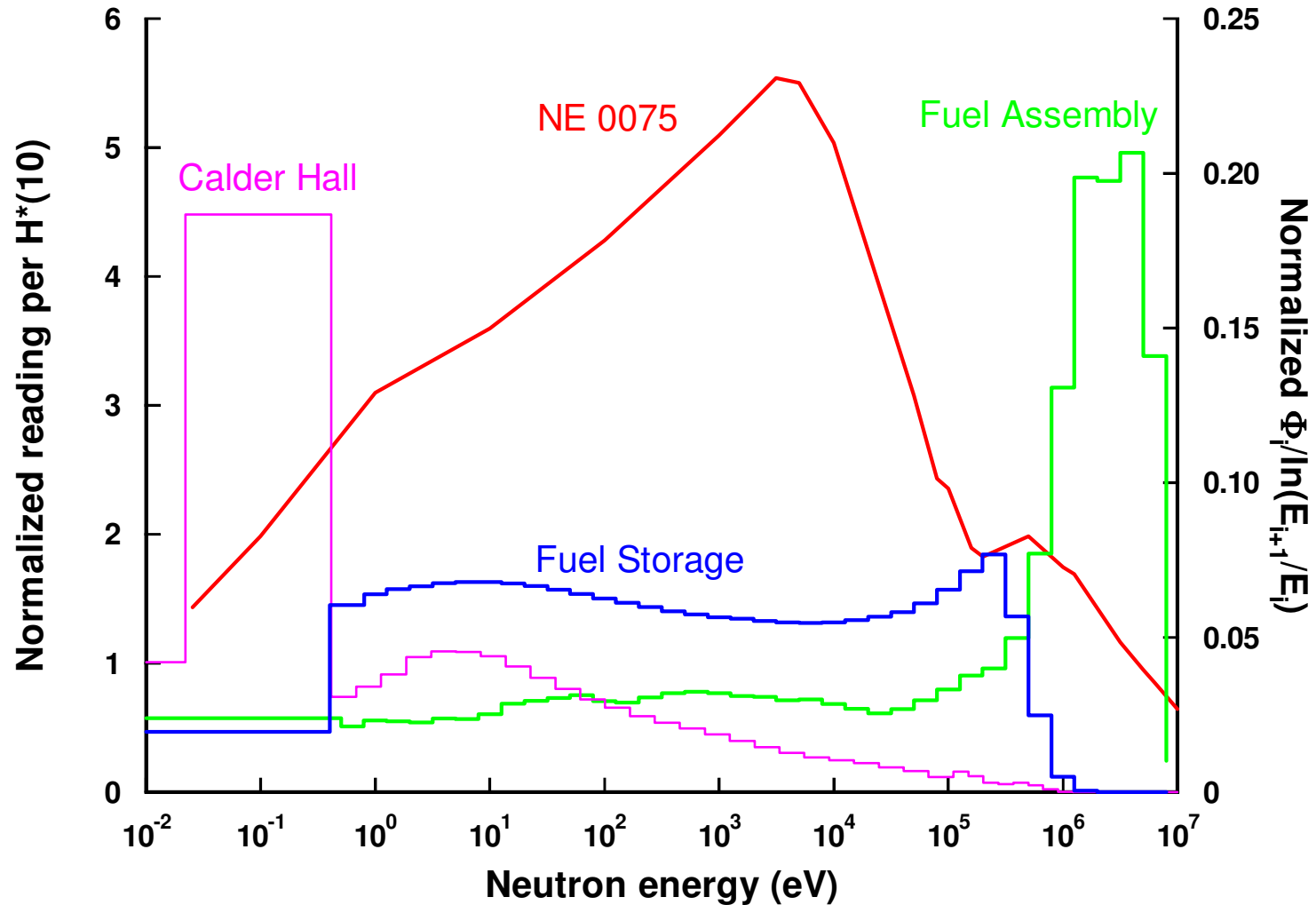

Modelling: MCNP-4C

Monte Carlo N-Particle code from Los Alamos

- Well benchmarked
- Transports neutrons, electrons and photons
- Flexible geometry
- Variance reduction (acceleration) techniques
- Can determine number of capture reactions in region of interest
- Cannot convert captures to pulse height spectrum, so assumes 100% efficiency

Leake design: MCNP input

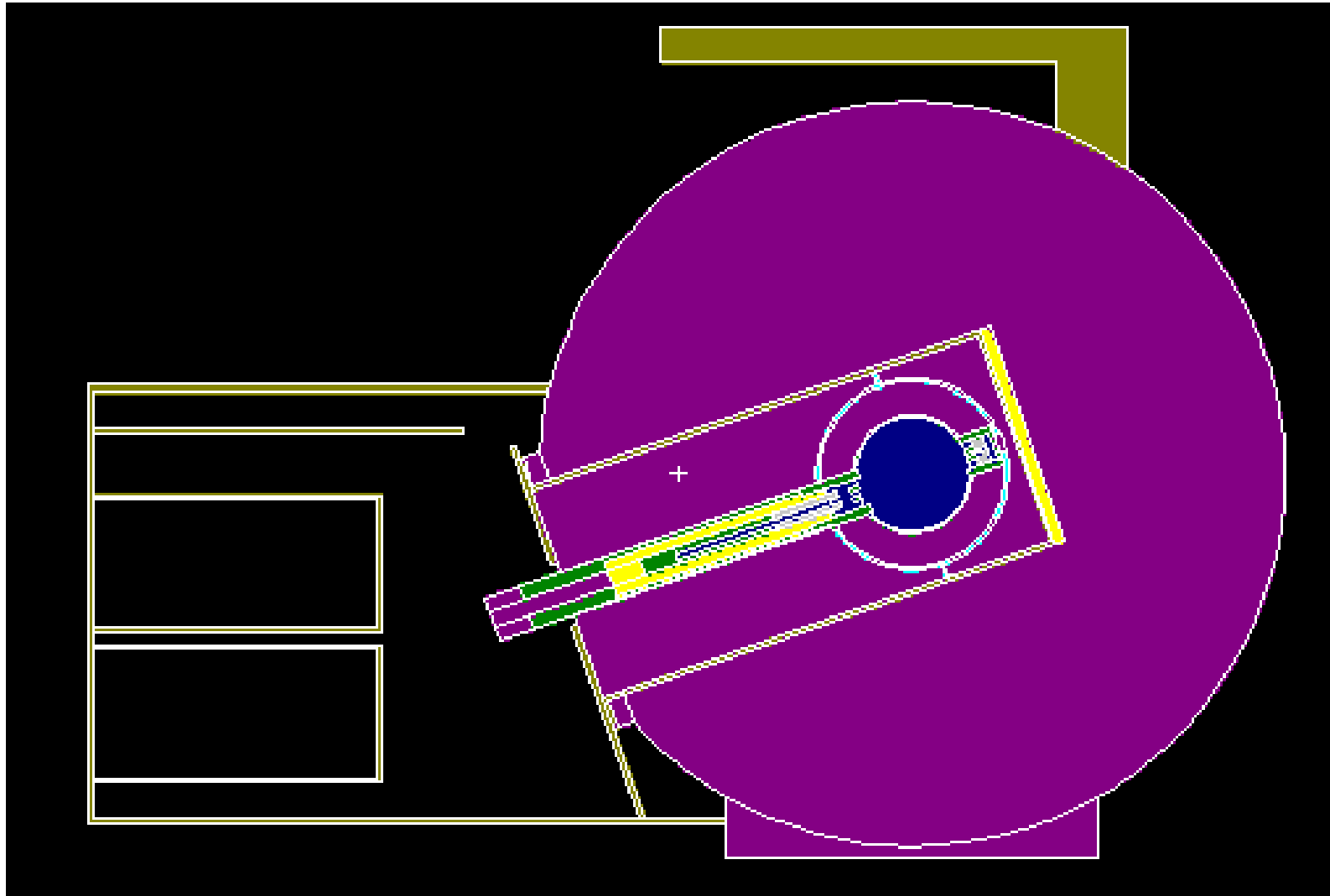

Leake design: MCNP input

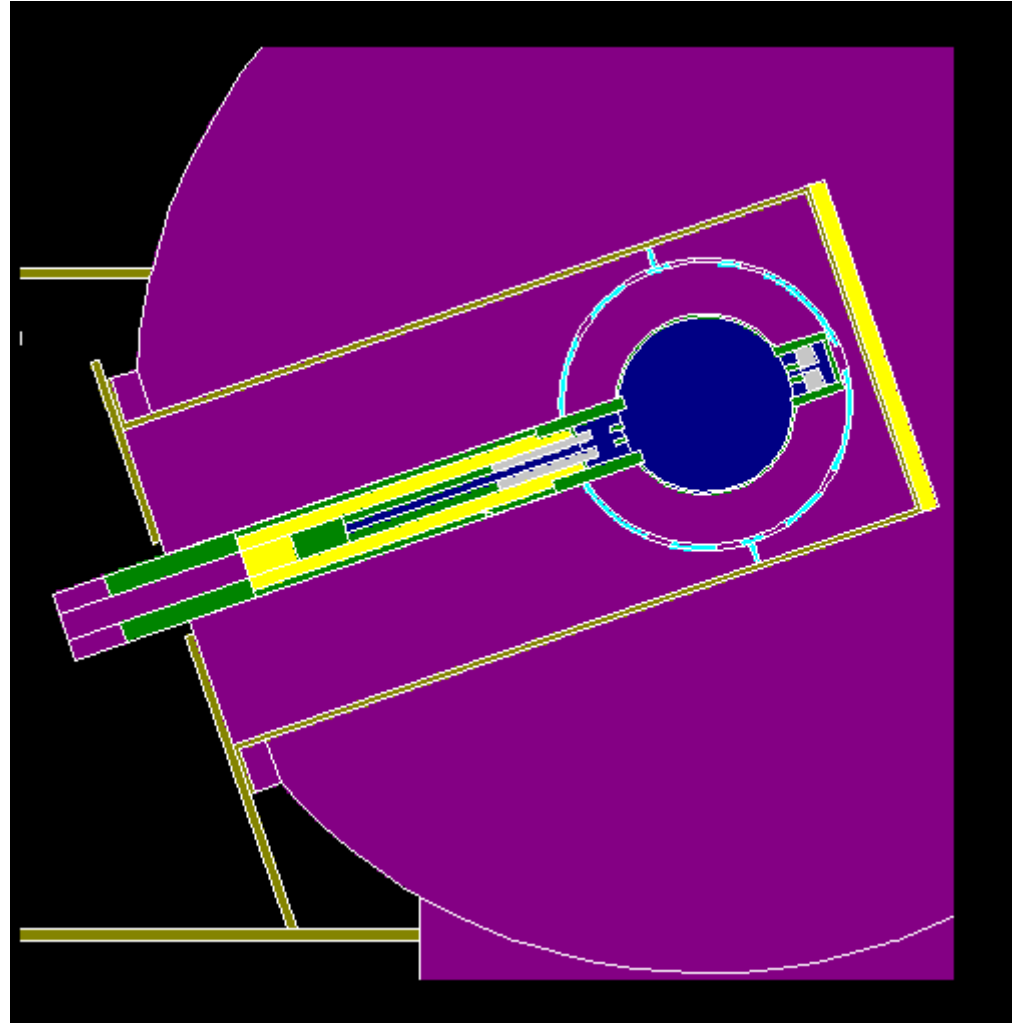

NM2 model: MCNP input

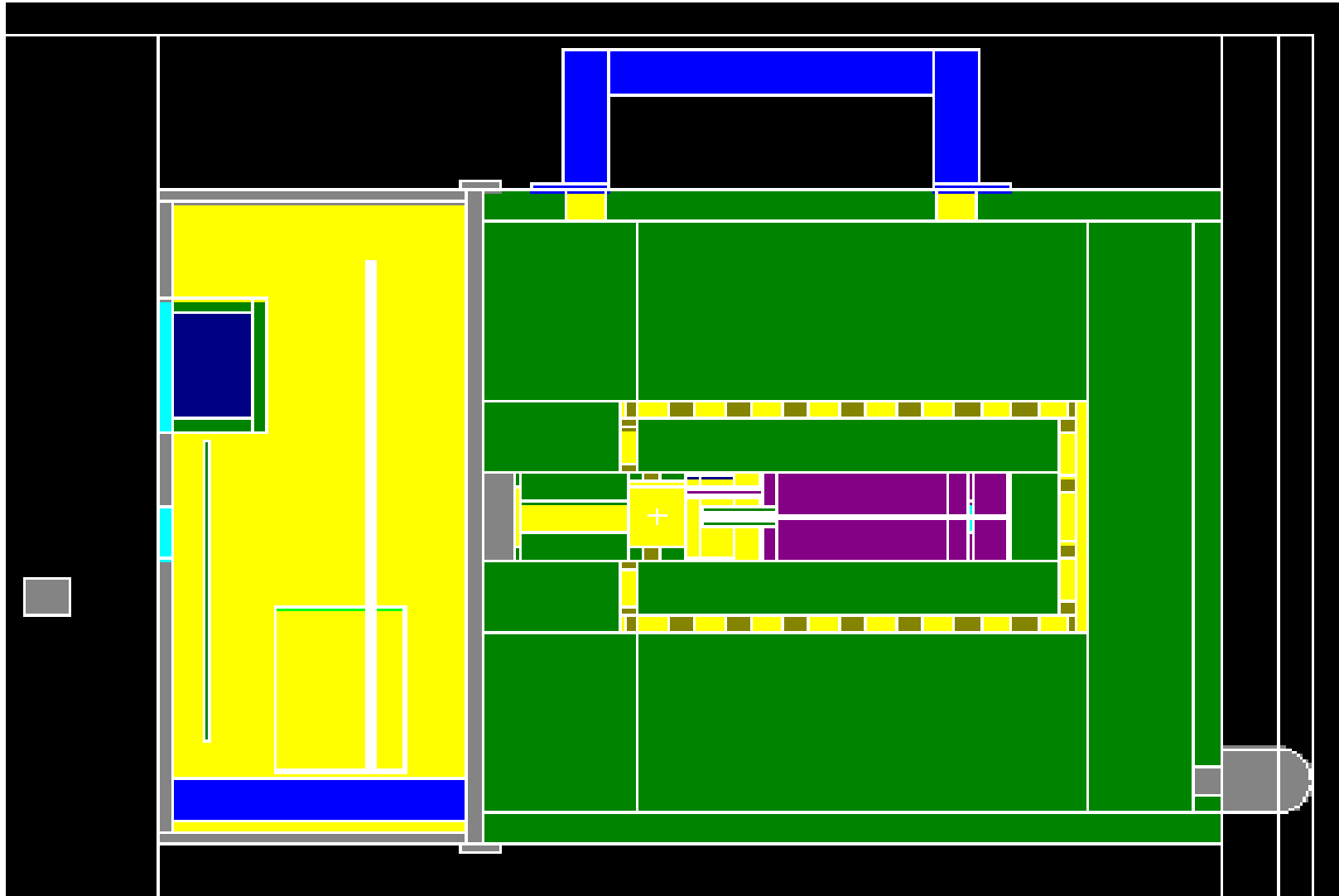

NM2 model: MCNP input

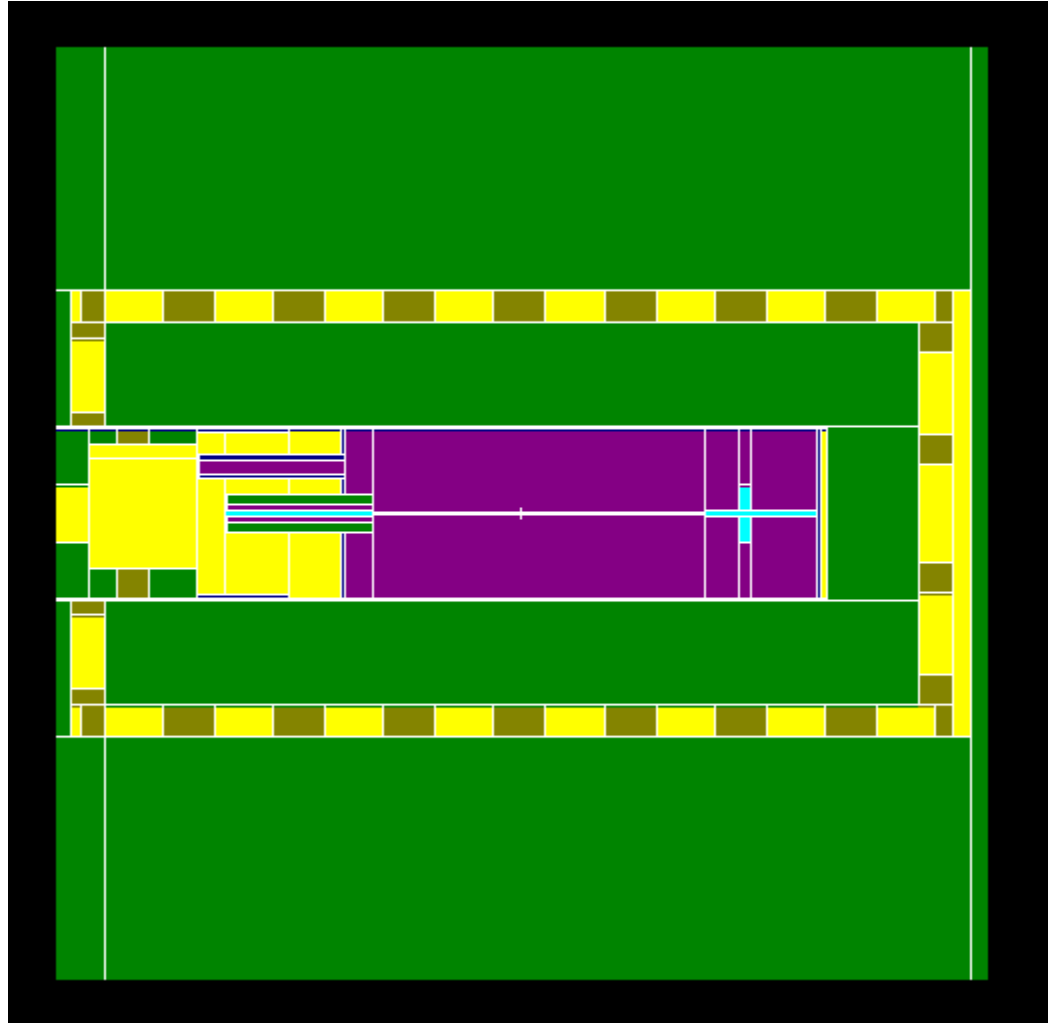

Studsvik 2222 model: MCNP input

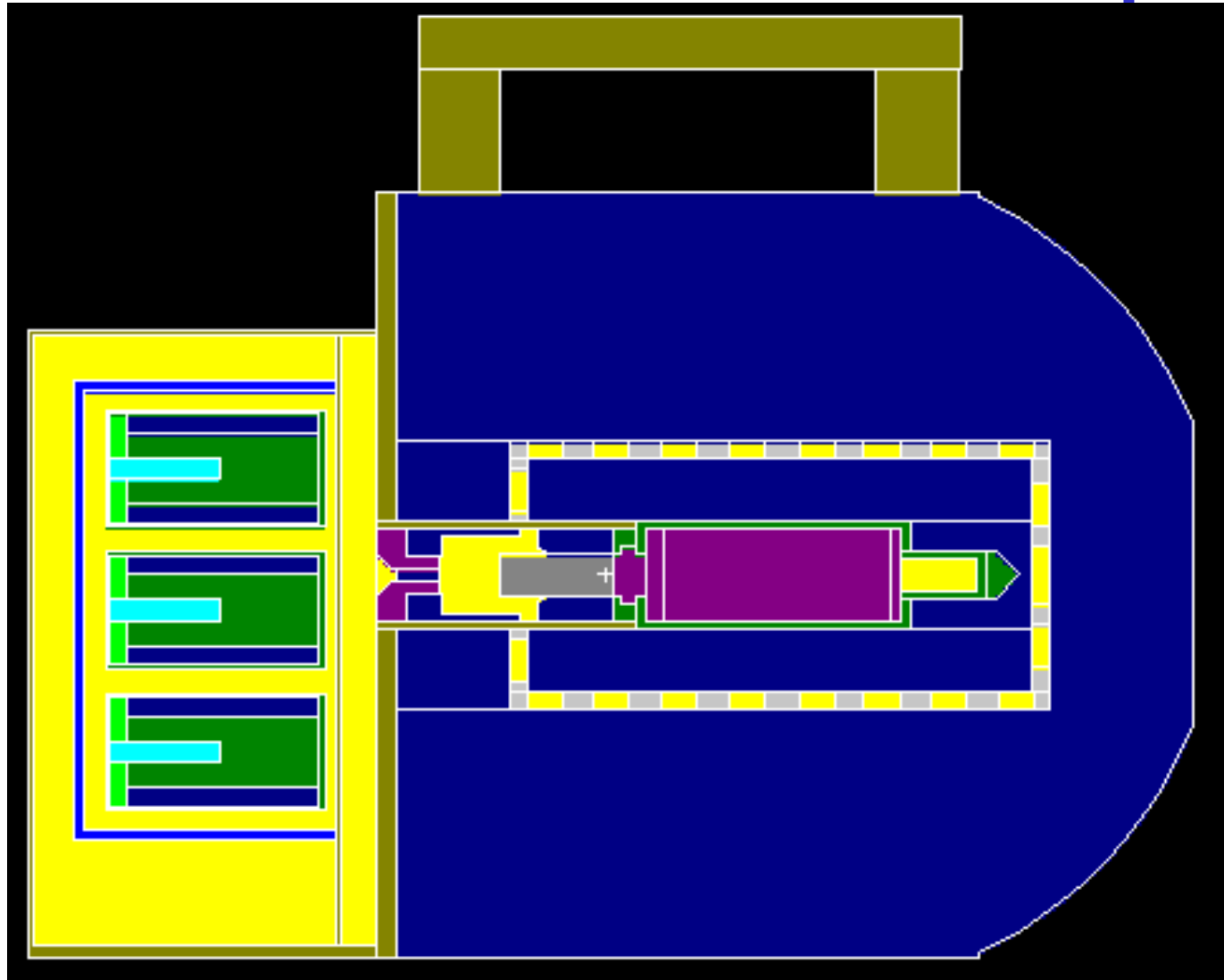

Radionuclide source data

Source	Instrument	Maximum	Minimum
^{252}Cf	Leake	0.97	1.30
^{252}Cf	NM1/2	0.95	1.02
^{252}Cf	Studsvik	0.86	1.08
$^{241}\text{Am-Be}$	Leake	0.95	1.24
$^{241}\text{Am-Be}$	NM1/2	1.08	1.45
$^{241}\text{Am-Be}$	Studsvik	0.98	1.15

⇒ Intrinsic instrument to instrument variability.

$H^*(10)/\phi$

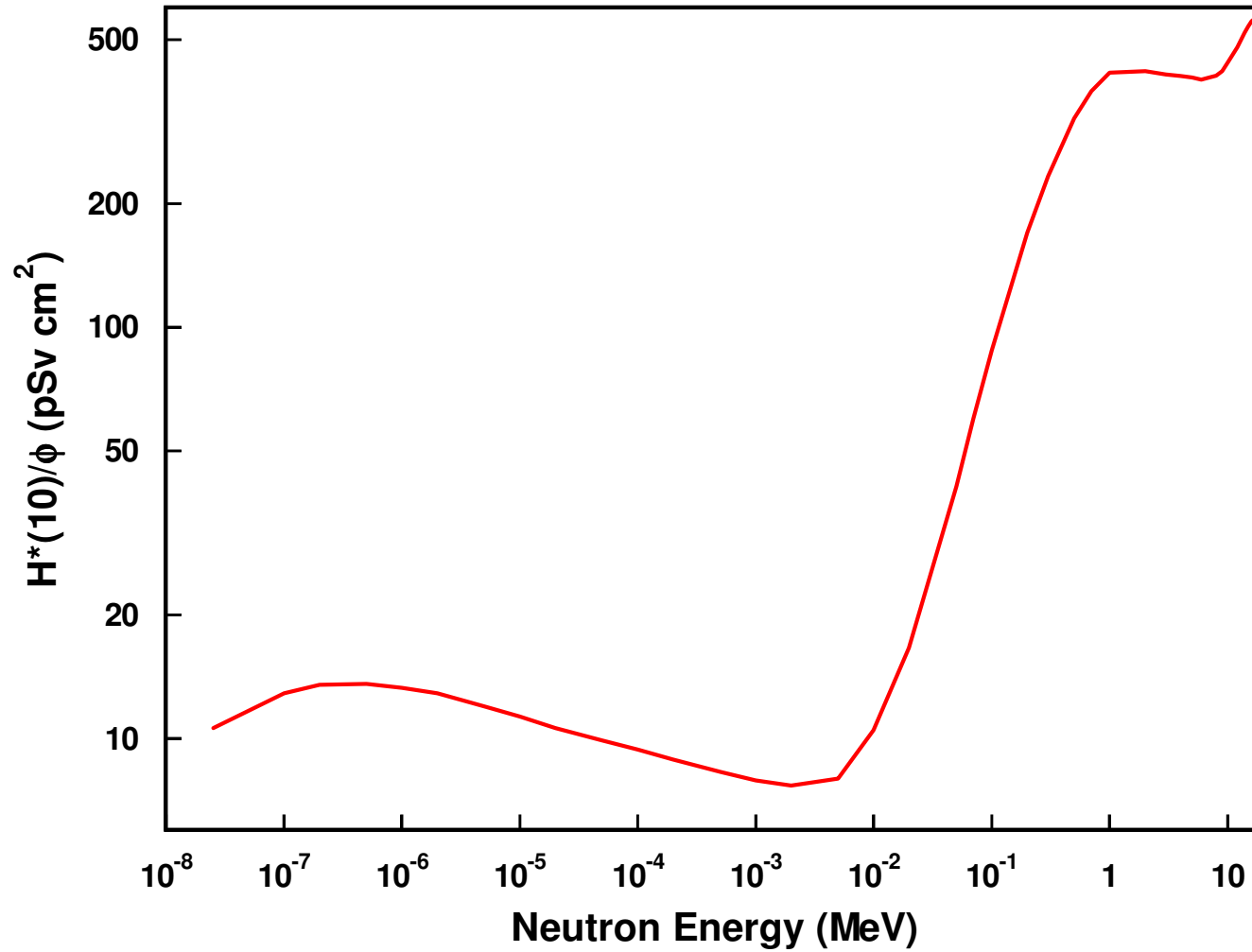

MCNP results: NM2

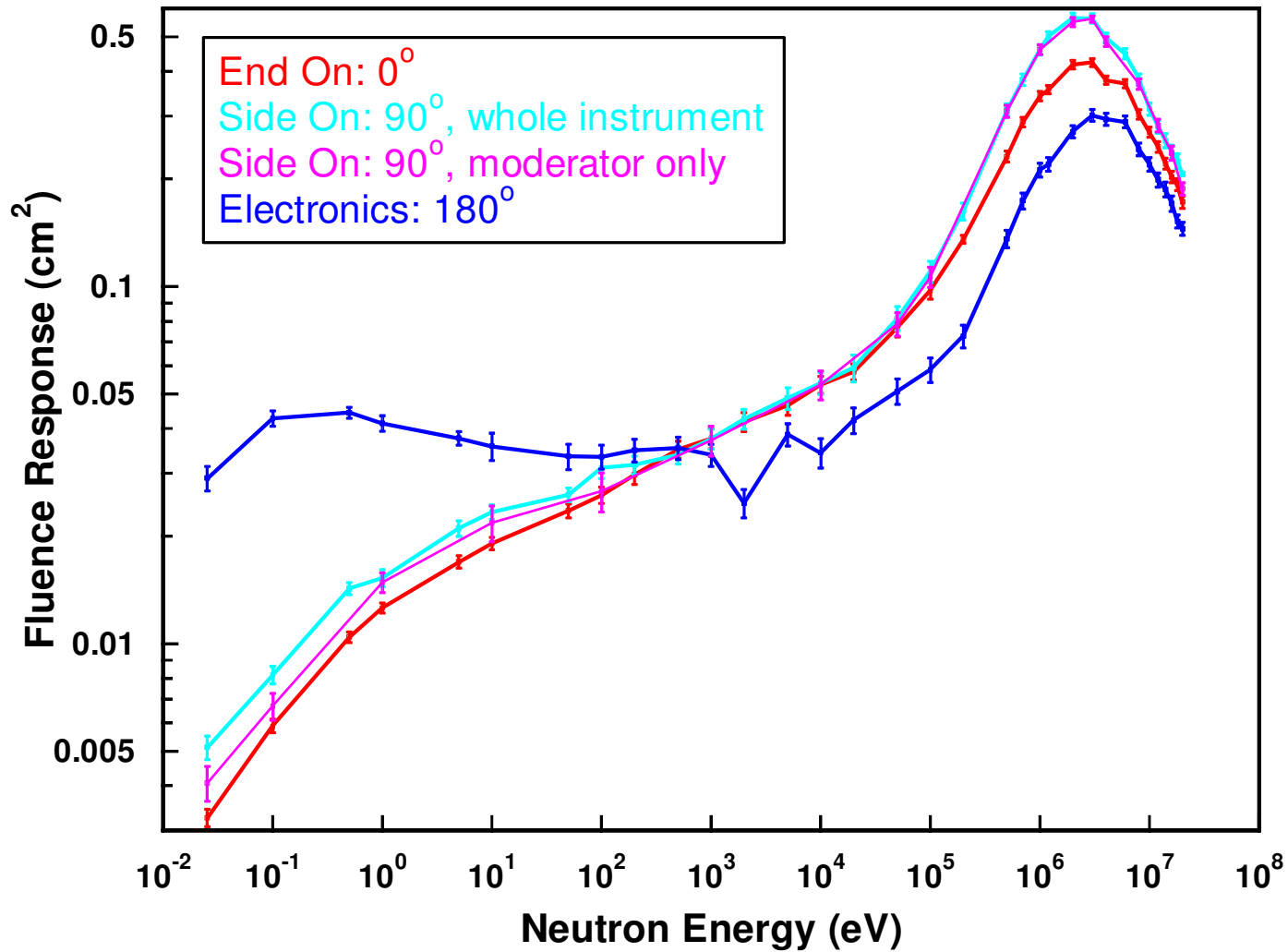

Leake design: MCNP vs experiment

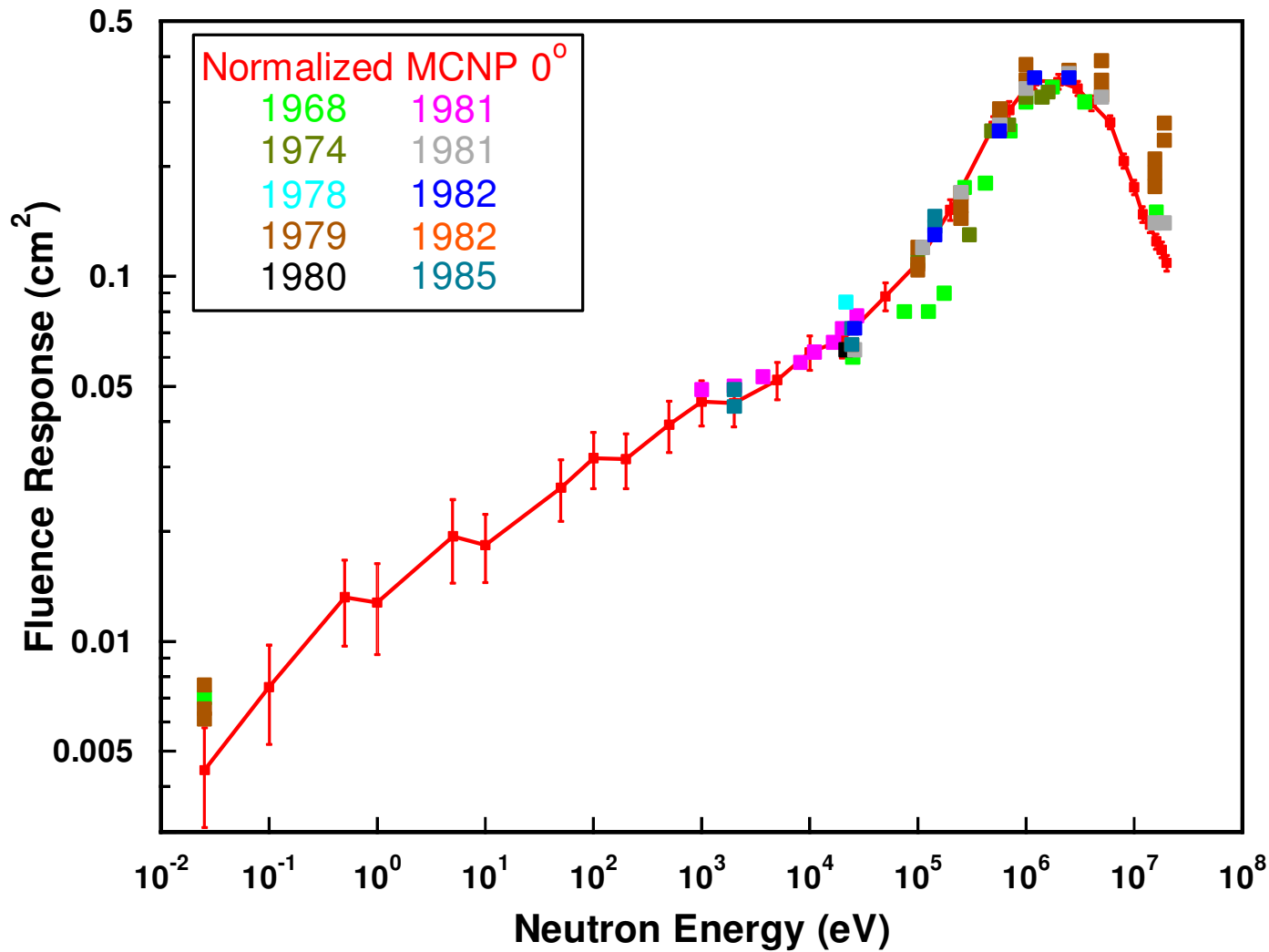

NM2: MCNP vs experiment

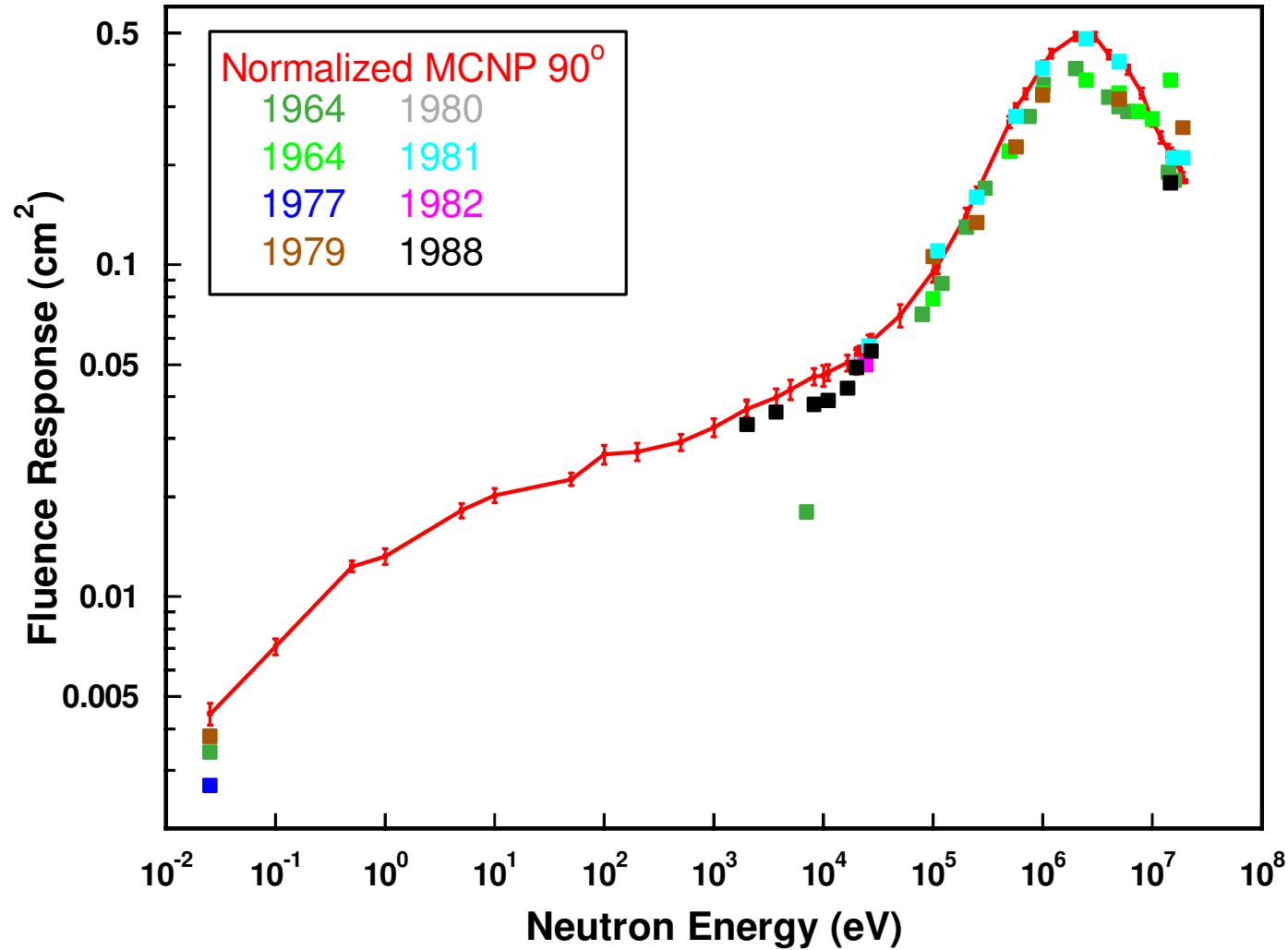

Studsvik: MCNP vs experiment

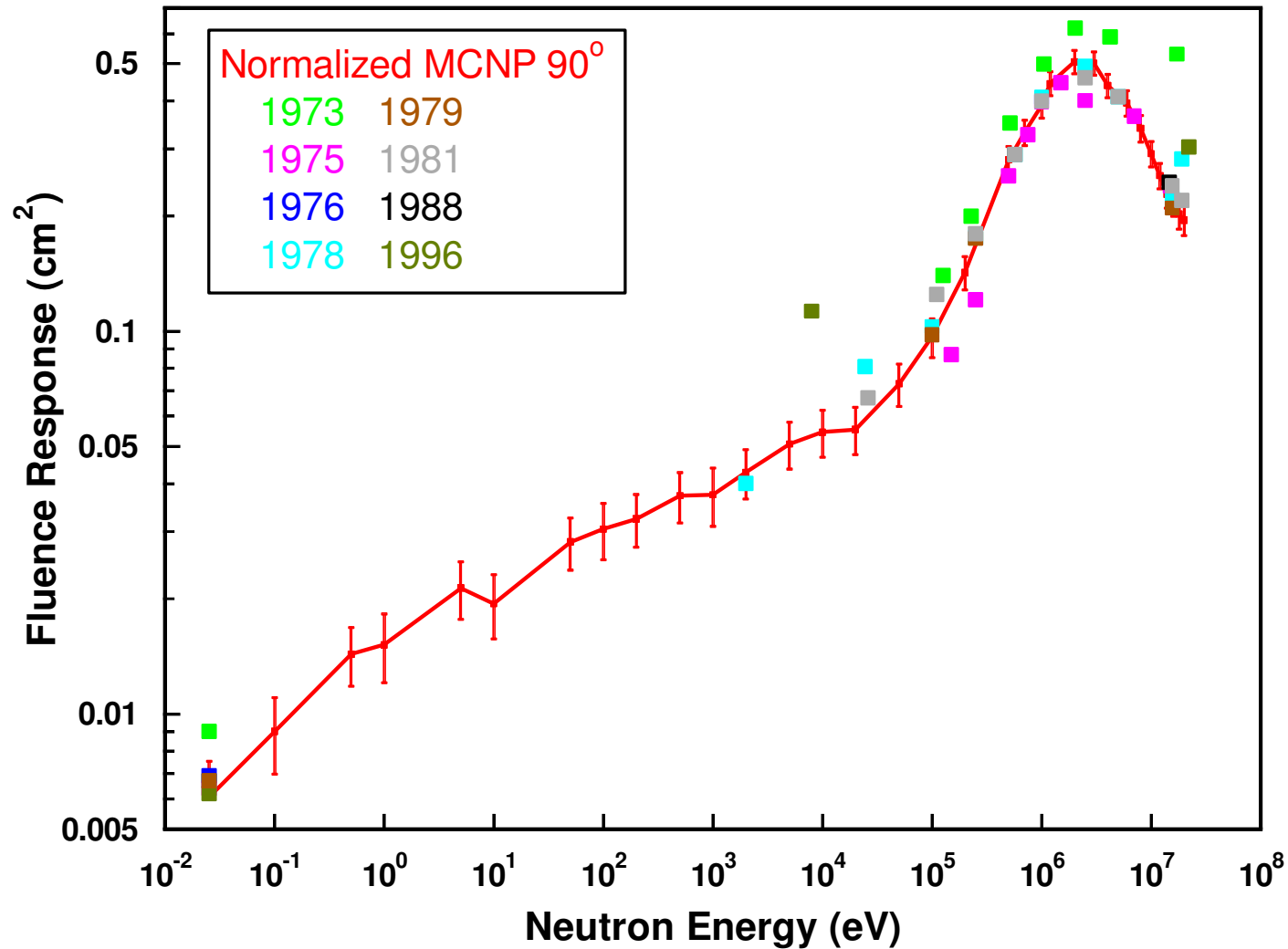

Modelling vs experiment

- General good agreement after normalization to account for detector efficiency
- Substantial scatter on the experimental data
- Experimental measurements vary considerably
- Large gap from thermal to around 1-10 keV with no experimental data
- New datasets self-consistent and detailed

Influence on predicted responses

- Can determine the response in a measured or calculated workplace field by folding the response function with the fluence-energy distribution
- Experimental data had previously been interpolated/fitted for all three instruments to yield 'best' response functions

Leake: MCNP vs old fits

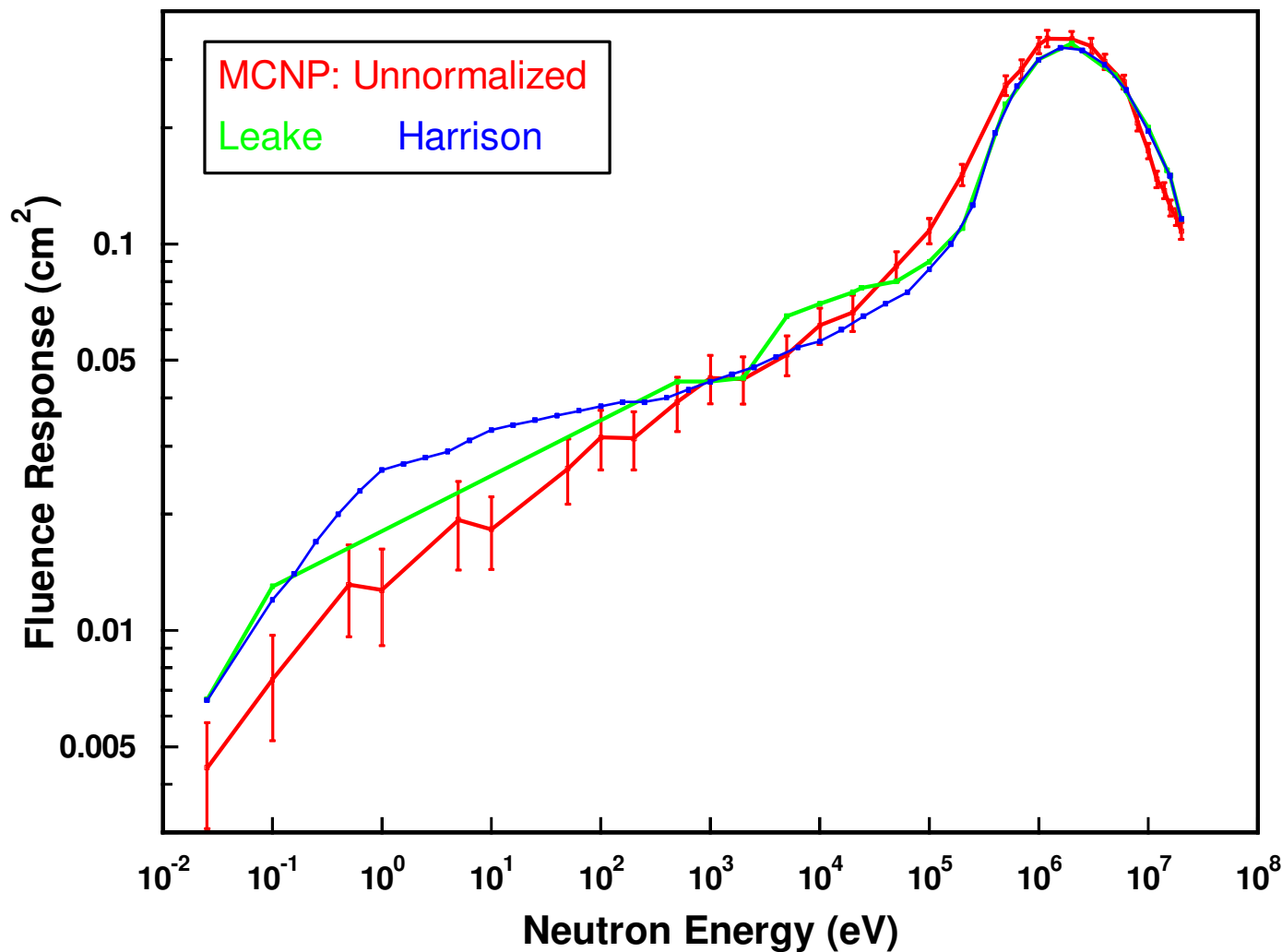

Leake: workplace fields

Field	MCNP/Harrison	MCNP/Leake
PWR site F	0.97	0.85
PWR site L	1.02	0.90
PWR site A	0.97	0.85
PWR site G	0.90	0.77
Fuel Storage	1.01	0.91
Magnox	0.78	0.67
MOX	1.06	1.02

Andersson-Braun: workplace fields

Field	NM2 MCNP/Old	Studsvik MCNP/Old
PWR site F	0.97	0.97
PWR site L	0.97	0.96
PWR site A	0.97	0.97
PWR site G	0.97	0.98
Fuel Storage	0.98	0.98
Magnox	0.97	0.98
MOX	0.98	1.00

Conclusions

- Instruments used in the UK are mainly of the Leake type, NM1/2 or Studsvik 2202/2222
- Many experimental data exist but they are old, and do not show great consistency
- New calculated response datasets are self consistent and detailed, AND agree with earlier data. They highlight large potential differences for irradiation through the electronics.
- These new response datasets have significant impact on the predicted responses of the Leake design, but less effect on the NM2 or Studsvik

Future work?

- New designs will be of increased importance in the UK: Berthold LB6411, Eberline SWENDI, Health Physics Inc. REM 500...
- Measurements are required to verify/enhance the normalization of calculated data
- Further calculations are required to identify model-to-model variations in response, and better understand the direction dependence of response
- The impact of these results for workplace measurements needs to be fully assessed

Final report imminent...

D T Bartlett, R J Tanner, H Tagziria and DJ Thomas, Response Characteristics of Neutron Survey Instruments, Chilton NRPB-R333 (2001) (~£15)

Or, in Adobe Acrobat format (free download):

<http://www.nrpb.org.uk/>